



Japan Ship Technology Research Association



MLIT

Ministry of Land, Infrastructure, Transport and Tourism

# Roadmap to Zero Emission from International Shipping

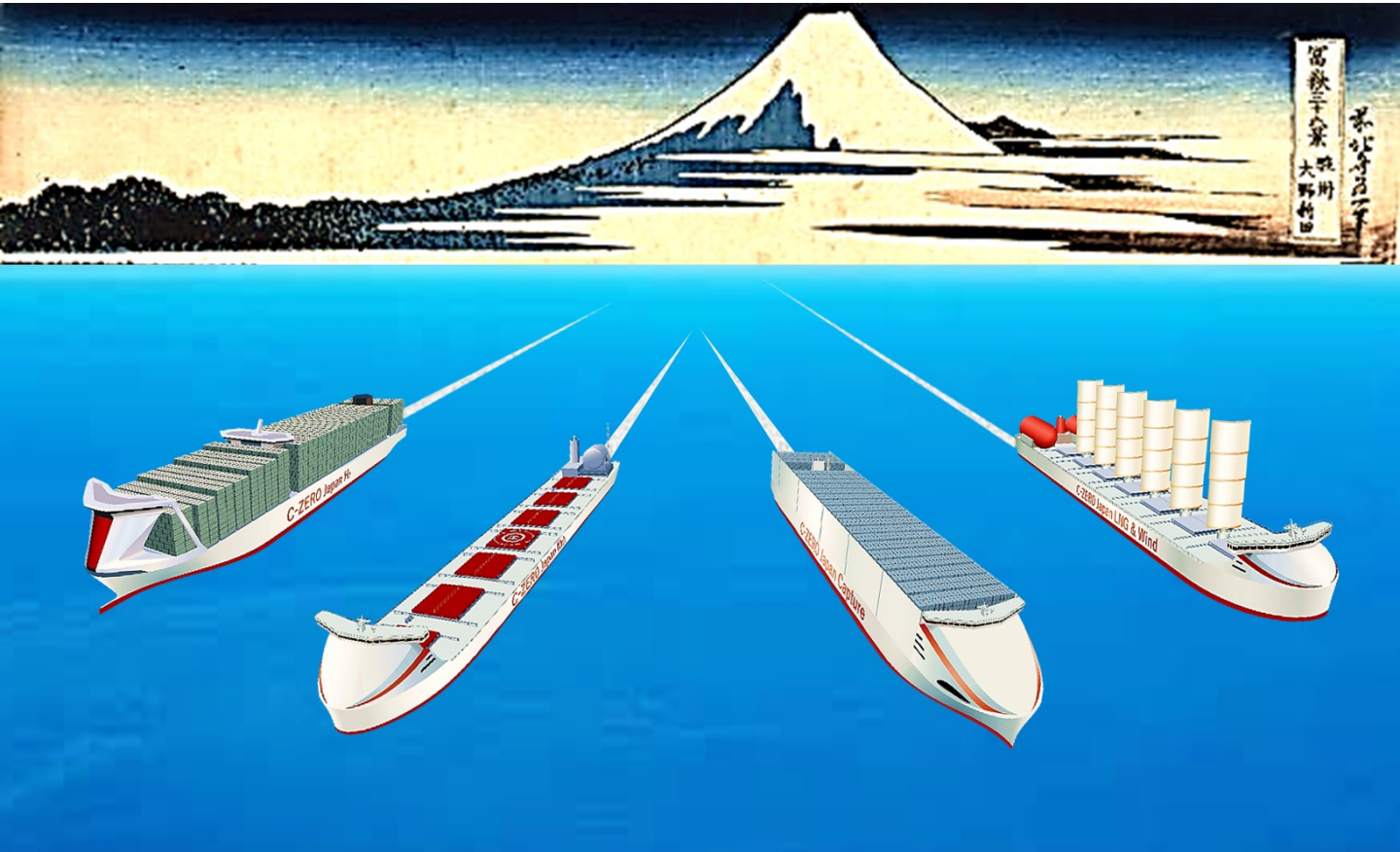

March 2020  
Shipping Zero Emission Project



## Foreword

Amid globally growing momentum for decarbonization since the Paris Agreement came into effect in 2016, further reduction of greenhouse gas (GHG) emissions has become an urgent issue in international shipping, which currently accounts for approximately 2% of global GHG emissions and is expected to significantly grow in the future. In April 2018, the International Maritime Organization (IMO) adopted the “*Initial Strategy on reduction of GHG emissions from ships*”, aimed at reducing the GHG emissions from international shipping by at least 50% by 2050 and phasing them out as soon as possible in this century. Currently, in accordance with the Strategy, discussion and consideration on short-term measures are underway at the IMO with a view toward reaching an agreement by 2023.

Japan is one of the major players in global shipping and shipbuilding sectors. In order to actively contribute to international actions to address the climate change while ensuring the sustainable growth of maritime transport and related industries, Japan established the “**Shipping Zero Emission Project**”, in collaboration with the industrial, academic, and public sectors, in August 2018. The Japan Ship Technology Research Association (JSTRA) and the Ministry of Land, Infrastructure, Transport and Tourism (MLIT) are taking the lead in organizing this project with the support from the Nippon Foundation.

### <Institutions and organizations participating in the Shipping Zero Emissions Project>



## Shipping Zero Emission Project

### <Steering Group Members>

Hiroaki Sakashita	Project Manager, International Shipping GHG Zero Emissions Project President & CEO, Nippon Kaiji Kyokai (ClassNK)
Ken Takagi	Professor, Department of Ocean Technology, Policy, and Environment, Graduate School of Frontier Sciences, The University of Tokyo
Akira Okada	Associate Professor, Environmental Management and Sustainability, Faculty of Environmental Studies, Tokyo City University
Tatsumi Kitahara	Associate Professor, Department of Mechanical Engineering, Graduate School of Engineering, Kyushu University
Seijiro Morimoto	Senior Researcher, Planning and Research Department, Japan Maritime Center
Katsuji Tanizawa	Managing Director for Research Affairs, National Maritime Research Institute, National Institute of Maritime, Port and Aviation Technology
Toshiyuki Matsumoto	Corporate Officer, Director of Research Institute, Nippon Kaiji Kyokai (ClassNK)
Hideyuki Asaoka	Senior Director, Joint Construction of Ship Assistance Department, Japan Railway Construction, Transport and Technology Agency (JRTT)
Kumiko Iwasa	General Manager, Environment Management Group, Kawasaki Kisen Kaisha, Ltd. ("K" Line)
Hirohiko Oyabu	Assistant to Director Technical Division Technology Innovation unit, Mitsui O.S.K. Lines, Ltd.
Masahiro Takahashi	General Manager, Environment Group, Nippon Yusen Kaisha (NYK Line)
Norihiro Wakiyama	Senior Staff Officer, Engineering Division, Ship & Offshore Structure Company, Kawasaki Heavy Industries, Ltd.
Tsuyoshi Ishiguro	Technical Executive, Design Division, Japan Marine United Corporation
Takashi Unseki	Chief Engineer, Energy & Environment, Marine Engineering Center, Mitsubishi Shipbuilding Co., Ltd.



Tomohiro Asaumi      Managing Director & General Manager, Design Division, Asakawa Shipbuilding Co., Ltd.

Hideaki Nagasawa      General Manager, Research & Development Department, Engineering & Technology Center, IHI Power Systems Co., Ltd.

Kazutaka Shimada      Assistant Manager, Designing Department, Diesel Division, Mitsui E&S Machinery Co., Ltd.

<Managers of Associate Projects>

Akihiko Azetsu      Project Manager, Project for Energy Efficiency Technical Standards, Japan Ship Technology Research Association  
Professor, Department of Mechanical Engineering, School of Engineering, Tokai University

Koji Takasaki      Project Manager, Project for Air Pollution Prevention Standards, Japan Ship Technology Research Association  
Professor Emeritus, Kyushu University

Organizer: Japan Ship Technology Research Association (JSTRA) and  
Ministry of Land, Infrastructure, Transport and Tourism (MLIT)

Support: The Nippon Foundation

This project has established three Task Forces under the Steering Group: the Task Force on ship design, the Task Force on ship operation, and the Task Force on alternative fuels. This project has been carried out with the participation of more than 50 experts from related industries and organizations.

## Table of Contents

Chapter 1	Introduction	...1
Section 1.1	Background	...1
Section 1.2	Purpose	...1
Section 1.3	Outline of the Project	...2
Chapter 2	The Initial IMO Strategy on Reduction of GHG Emissions from Ships and Perspectives on Achieving its Targets	...3
Section 2.1	Targets Set by the Strategy	...3
Section 2.2	Toward Achieving the 2030 Target	...4
Section 2.3	Toward Achieving the Target for 2050	...4
Section 2.4	Toward Achieving Zero Emissions in This Century	...5
Chapter 3	Measures for Achieving the 2030 Target	...6
Section 3.1	Improving the Energy Efficiency of New Ships (EEDI Regulations)	...6
Section 3.2	Improving the Energy Efficiency of Existing Ships	...6
3.2.1	Necessity of Measures on Existing Ships	...6
3.2.2	Development of New Energy Efficiency Regulations on Existing Ships	...7
3.2.3	Estimation of the GHG Reduction Effects by means of EEXI Regulations	...8
Section 3.3	Towards further Operational Improvements	...8
Chapter 4	Emission Pathways for Achieving the 2050 Target	...9
Section 4.1	Outline of the Development of Emission Pathways	...9
Section 4.2	Estimate of International Seaborne Trade and Required Reduction of GHG emissions	...9
4.2.1	Estimate of International Seaborne Trade	...9
4.2.2	Estimate of GHG Emissions in Business-As-Usual (BAU) Scenario: Continued Use of Conventional Technologies and Fuels	...12
4.2.3	Reduction in GHG Emissions and Carbon Intensity Required to Achieve the 2050 Target	...13
Section 4.3	Reduction in GHG Emissions and Carbon Intensity Required to Achieve the 2050 Target	...14
4.3.1	Feasibility Study on Potential Fuels and Technological Options	...14
4.3.2	Emission Pathways for Achieving the 2050 Target and beyond	...19
Section 4.4	Concept Designs for Ultra-low or Zero Emission Ships	...25
4.4.1	Hydrogen-Fueled Ships	...25
4.4.2	Ammonia-Fueled Ships	...28
4.4.3	Onboard CO2 Capturing Ship	...29

4.4.4	Super-efficient LNG-Fueled Ships	...30
4.4.5	Conceptual Drawings of Zero Emission Ships	...32
Chapter 5	Roadmap to Zero Emission from International Shipping	...33
Section 5.1	Outline of the Roadmap	...33
Section 5.2	Research and Development	...34
5.2.1	Enhancing Research and Development capacities	...34
5.2.2	Pilot Projects	...34
Section 5.3	Regulatory Developments	...35
5.3.1	Short-, Mid- and Long-Term Measures	...35
5.3.2	Revision to Existing MARPOL-Related Regulations	...36
5.3.3	Safety requirement	...36
5.3.4	Others	...36
Chapter 6	Concluding remarks	...38
Appendix 1	Estimate of International Seaborne Trade	...41
Appendix 2	Feasibility of Alternative Fuels and GHG Reduction Technologies	...59
Appendix 3	Ultra-low or Zero Emission Ships	...73
Appendix	Hydrogen-Fueled Ships	...73
3-1		
Appendix	Ammonia-fueled Ships	...86
3-2		
Appendix	Onboard CO <sub>2</sub> Capturing Ship	...96
3-3		
Appendix	Super-efficient LNG-fueled Ships	...107
3-4		
Appendix 4	Life cycle accounting of GHG emissions	...127

# Chapter 1: Introduction

## Section 1.1: Background

According to the study on greenhouse gas (GHG) emissions from international shipping conducted by the International Maritime Organization (IMO) in 2014, total CO<sub>2</sub> emissions from international shipping as of 2012 was approximately 800 million tons, around 2.2% of global CO<sub>2</sub> emissions. Demand for maritime transport is forecasted to increase amid the growth of the world economy.

Measures for tackling the climate change in a global manner are being discussed under the United Nations Framework Convention on Climate Change (UNFCCC). However, GHG emissions from international shipping and aviation sectors operating beyond national borders are difficult to be separated and allocated to countries, by nationality of the ship or aircraft, or by the country that operates them. Thus, actions to reduce emissions from these sectors are not compatible with the country-specific reduction measures of the UNFCCC. For these reasons, discussions on measures on these sectors have been delegated to United Nations specialized agencies, the IMO and the International Civil Aviation Organization (ICAO), respectively.

The IMO adopted the initial IMO Strategy on Reduction of GHG emissions from Ships (hereafter “**the IMO Strategy**”) to reduce GHG emissions from ships in April 2018. The IMO Strategy sets quantified GHG reduction targets: (1) to reduce carbon intensity (i.e. CO<sub>2</sub> emissions per transport work) of international shipping by at least 40% by 2030 compared to 2008, (2) to reduce the total annual GHG emissions from international shipping by at least 50% by 2050 compared to 2008, and (3) to phase out GHG emissions from international shipping as soon as possible, in this century.

The international shipping sector had already been making efforts to reduce the GHG emissions from ships prior to the adoption of the IMO Strategy. For example, it had introduced the mandatory energy efficiency design index (EEDI) for new ships. However, to achieve the targets under the IMO Strategy, especially the targets for 2050 and beyond, it is necessary to not only continue these ongoing efforts but also to introduce and speed up actions that goes beyond the conventional ones, such as transition from fossil and other conventional fuels to low- and zero-carbon fuels and introduction of innovative technologies.

As a major player in global shipping and shipbuilding sectors, Japan should take the lead in the global actions to tackle the climate change in a manner that stimulates innovation and sustainability of global maritime industry.

Under these circumstances, the Shipping Zero Emissions Project (hereinafter “the Project”), in collaboration with the industrial, academic, and public sectors, was launched in August 2018.

## Section 1.2: Purpose

In light of the background mentioned above, the Project carried out a research to clarify what actions

should be carried out by the maritime sector to meet the reduction targets set out in the IMO Strategy. It further plotted the details and schedules of technological development and the environmental preparations necessary for the said actions onto a roadmap, which would thereby provide materials for maritime industries in determining and implementing the actions.

### **Section 1.3: Outline of the Project**

This report outlines the results of the Project in the structure mentioned below.

- (1) Summary of the Initial IMO Strategy on reduction of GHG emissions from ships and perspectives on achieving its targets (Chapter 2)
- (2) Measures for achieving the 2030 target (Chapter 3)
- (3) Emission pathways for achieving the targets for 2050 and beyond (Chapter 4)
- (4) The roadmap to zero emission from international shipping (Chapter 5)

# Chapter 2: The Initial IMO Strategy on Reduction of GHG Emissions from Ships and Perspectives on Achieving its Targets

## Section 2.1: Targets Set by the Strategy

In April 2018, the Initial IMO Strategy on reduction of GHG emissions from ships (hereafter “**the IMO Strategy**”) was adopted at the 72nd session of the IMO’s Marine Environment Protection Committee (MEPC 72). Figure 2.1-1 gives an overview of the IMO Strategy. The IMO Strategy sets the following GHG reduction targets:

- To reduce carbon intensity (i.e. CO<sub>2</sub> emissions per transport work) of international shipping by at least 40% by 2030, compared to 2008
- To reduce the total annual GHG emissions from international shipping by at least 50% by 2050, compared to 2008
- To phase out GHG emissions from international shipping as soon as possible, in this century

In addition, the IMO Strategy specifies candidate measures for the reduction of GHG emissions for achieving the targets mentioned above. They are classified into three types as follows:

- Short-term measures: To be agreed between 2018 and 2023 (e.g. technical and operational energy efficiency measures for both new and existing ships)
- Mid-term measures: To be agreed between 2023 and 2030 (e.g. the introduction of low-carbon fuels and market-based measures (MBM))
- Long-term measures: To be agreed beyond 2030 (e.g. the introduction of zero-carbon fuels)

Currently, the IMO is deliberating the short-term measures to achieve the 2030 target in accordance with the IMO Strategy. Japan is proactively contributing to the work at the IMO by submitting concrete proposals on energy efficiency improvement of existing ships. (Details to be discussed later.)



## IMO's initial GHG Reduction Strategy (Apr 2018)

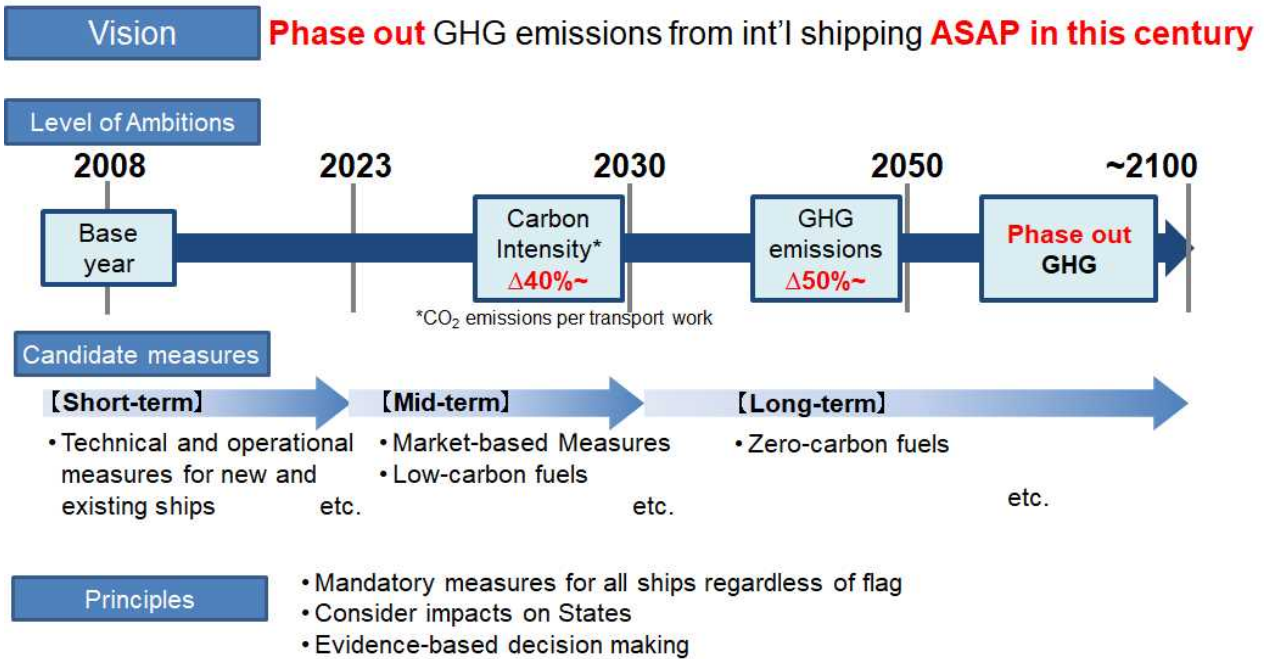

Figure 2.1-1: Overview of IMO Strategy

### Section 2.2: Toward Achieving the 2030 Target

As a mandatory measure to improve energy efficiency, the energy efficiency design index (EEDI) requirements on new ships under the International Convention for the Prevention of Pollution from Ships (MARPOL) has been established at the IMO and implemented since 2013. The required improvements under the measure have been gradually strengthened and scheduled to be strengthened further in 2022 and 2025.

However, the 2030 target will not be met by the measure on new ships only. Therefore, it is considered that a new energy efficiency measure on existing ships needs to be introduced and implemented. The new measure on existing ships are discussed in detail in Chapter 3.

### Section 2.3: Toward Achieving the Target for 2050

It is yet challenging to achieve the 2050 target only by means of design and operational improvement regulations on new and existing ships. To achieve the 2050 target, introduction of low/zero-carbon alternative fuels and innovative technologies which are capable of cutting GHG emissions substantially should take place in time. Emission pathways for achieving the target for 2050 as well as a Roadmap to realize those pathways are discussed in detail in Chapter 4.

## **Section 2.4: Toward Achieving Zero Emissions in This Century**

To achieve zero GHG emissions as soon as possible in this century, the use of zero-carbon fuels emitting no CO<sub>2</sub> or the onboard CO<sub>2</sub> capturing technology would be necessary.

In considering the pathways and Roadmap toward 2050, it is essential to identify and select alternative fuels and innovative technologies that would lead to the achievement of zero GHG emissions from international shipping.



## Chapter 3: Measures for Achieving the 2030 Target

### Section 3.1: Improving the Energy Efficiency of New Ships (EEDI Regulations)

The EEDI regulations impose a standardized energy efficiency index<sup>1</sup> to mandate new ships to ensure that their energy efficiency is equivalent or superior to a predetermined requirement level (the required EEDI). In July 2011, the IMO adopted amendments to MARPOL Annex VI which entered into force in 2013. The required EEDI is established for each category of ship type and size, and is applied equally to all ships engaging in international shipping regardless of their flags. The required EEDI is gradually strengthened in a phased basis as shown in Table 3.1-1.

Table 3.1-1: The Level of Required EEDI under MARPOL Annex VI

	Year of application (on the basis of the shipbuilding contract)	Required EEDI
Phase 0	2013-	Average EEDI of ships built between 1999 and 2008
Phase 1	2015-	10% better than Phase 0
Phase 2	2020-	20% better than Phase 0
Phase 3	2022- / 2025-	30% to 50% better (determined by ship type and by size) than Phase 0

### Section 3.2: Improving the Energy Efficiency of Existing Ships

#### 3.2.1 Necessity of Measures on Existing Ships

Although the EEDI regulations have been implemented since 2013, existing ships contracted before the entry into force of the EEDI are not yet subject to any energy efficiency requirements under the IMO instruments.

By analyzing the trend of existing and new ships, it was found that existing ships tend to have engines with higher output allowing wider choice of operating speeds, while new ships subject to the EEDI regulations tend to have engines with a low output achieving better energy efficiency but allowing narrower choice of operating speeds.

Under these circumstances, there is limited incentive to replace old ships with new ships. Consequently, existing ships emitting more GHG are likely remain in the market for a long time. This may result in the stagnation of GHG emissions reduction for the entire shipping sector.

In light of that, it was found necessary to introduce a mandatory framework to improve the energy efficiency of existing ships, which would also have an effect to incentivize replacements to new ships and uptake of better energy saving technologies.

---

<sup>1</sup> EEDI: stands for Energy Efficiency Design Index. Its value refers to the CO<sub>2</sub> emissions for transporting one ton of cargo for one mile.

### 3.2.2 Development of New Energy Efficiency Regulations on Existing Ships

The Project examined what kind of regulatory framework would effectively and feasibly improve the energy efficiency of existing ships and then developed a concrete proposal, the energy efficiency existing ship index (EEXI), which was submitted by the government of Japan to the IMO with a view of adoption by 2023.<sup>2</sup> Figure 3.2.2-1 portrays the framework of the EEXI.

The EEXI regulations require existing ships to calculate their energy efficiency performance using index equivalent to the EEDI, and to meet the predetermined level (required EEXI). Implementation and enforcement of the EEXI, including survey and certification, broadly follow those of the EEDI regulations. Existing ships that fail to comply with the required EEXI with their original performance will need to improve efficiency by limiting the engine power (speed optimization by technical means), installation of energy saving device or any other verifiable measures.

On contrary, new and existing ships with superior energy efficiency performance that already meet the required EEXI will not be required to take additional measures. The poorer the energy efficiency performance, the more improvements are needed.

The required EEXI is currently proposed to be the same as the required EEDI applied to new ships contracted in 2022 (i.e., phase 2 or phase 3 equivalent, depending on ship types).

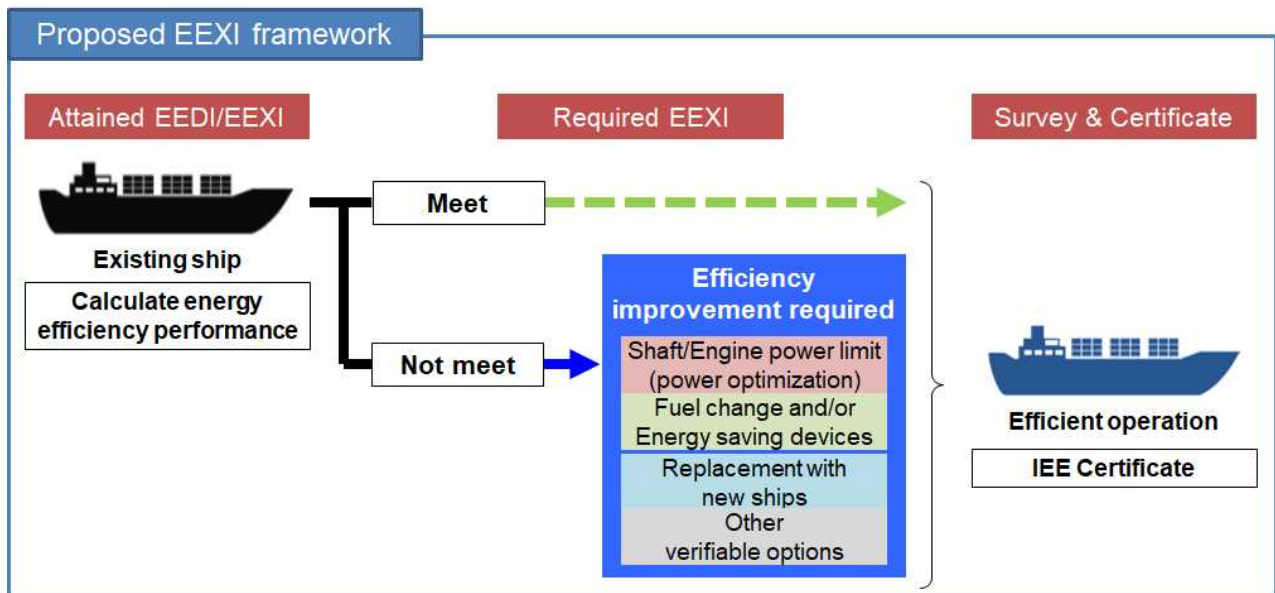

Figure 3.2.2-1: Overview of Framework of EEXI Regulations

<sup>2</sup> The EEXI regulations were proposed to the IMO’s Marine Environment Protection Committee (MEPC) in April 2019.

### **3.2.3 Estimation of the GHG Reduction Effects by means of EEXI Regulations**

The effect of EEXI regulations on operational efficiency by 2030 has been estimated. Assuming that existing ships are required to meet the same level as the EEDI regulations applicable to ships contracted in 2022 (equivalent to EEDI Phase 2 or 3), the average operational energy efficiency over the global fleet as of 2030 is estimated to be more than 40% better than the 2008 level. This means that a combination of the EEDI regulations and the EEXI regulations will open the way for the achievement of the 2030 target set by the IMO.

### **Section 3.3: Towards further Operational Improvements**

The EEDI and EEXI regulations are intended to raise the energy efficiency of international shipping as a whole by imposing an obligation on all ships to meet the predetermined requirements. However, this alone would not incentivize further energy efficiency improvement beyond the compulsory requirements. A combination with measures to incentivize further operational improvements will help accelerate the reduction of GHG emissions for the shipping sector as a whole. Therefore, development of a global incentive mechanism should be pursued in addition to the EEDI and EEXI regulations at the IMO.

# Chapter 4: Emission Pathways for Achieving the 2050 Target

## **Section 4.1: Outline of the Development of Emission Pathways**

In the Project, GHG emission pathways were developed through the following steps:

- (1) Estimate business-as-usual (BAU) GHG emissions<sup>3</sup> from international shipping up to 2050;
- (2) Calculate the minimum reductions in GHG emissions and carbon intensity (i.e. CO<sub>2</sub> emissions per transport work) required to achieve the 2050 target; and then
- (3) Develop emission pathways that achieve the 2050 target based on the analyses on the emissions reduction potential of different alternative fuels and technologies.

## **Section 4.2: Estimate of International Seaborne Trade and Required Reduction of GHG emissions**

### **4.2.1 Estimate of International Seaborne Trade**

For the purpose of projecting BAU GHG emissions from international shipping up to 2050, international seaborne trade in ton-miles by ship type and size were estimated with a model using socio-economic indicators, including gross domestic product (GDP), population, and energy consumption. The results are outlined in the following sections. (For details, refer to **Appendix 1**.)

#### **4.2.1.1 Regression Formula of International Seaborne Trade on Socio-Economic Indicators**

Regression models were created on the assumption that international seaborne trade in tons by commodity are closely correlated with GDP, population, energy consumption and other socio-economic indicators. To determine the models, following data were used:

- international seaborne trade for crude oil, oil products, coking coal, steam coal, iron ore, bauxite/alumina, grain, minor bulk, containers, other dry cargo, liquefied petroleum gas (LPG), liquefied natural gas (LNG), chemicals, cars, reefer, and cruise passengers provided by Clarksons;
- GDP values published by the Organisation for Economic Co-operation and Development (OECD);
- population published by United Nations; and
- energy consumption published by the International Energy Agency (IEA).

#### **4.2.1.2 Estimate of International Seaborne Trade in Tons**

International seaborne trade (in tons) up to 2050 were estimated by the regression models mentioned in the previous section by inputting projected GDP, population and energy consumption. For this purpose,

---

<sup>3</sup> In the Project, Business-As-Usual (BAU) GHG emissions is defined as the amount of CO<sub>2</sub> emissions in the future assuming that no CO<sub>2</sub> emission reduction measures will be taken from 2008 onwards, that the state of marine transport (ship speed, ship type and size distribution, etc.), design technologies, fuels and others will be maintained, and that the average energy efficiency will remain unchanged.

following data were used: the OECD’s GDP forecast up to 2050; and projections on population and energy consumption based on the Representative Concentration Pathways (RCPs) and the Shared Socioeconomic Pathways (SSPs) adopted by the Intergovernmental Panel on Climate Change (IPCC) with some modification as described below. In the Project, estimates on population and energy consumption in 2030, 2040 and 2050 corresponding to the RCP 4.5, RCP 2.6 and RCP 1.9 scenarios, mentioned in Table 4.2.1-1, were used. With regard to socioeconomic conditions, SSP 1 scenario with modification to GDP value with OECD’s projection was used (hereinafter referred to as OECD, SSP 1). Table 4.2.1-2 shows the international seaborne trade forecast up to 2050 expressed as a factor of those in 2008 (standardized to 1), which was approximately 8.6 billion tons. International seaborne trade in 2050 are estimated to be little less than the double of the 2008 level under the OECD, SSP 1/RCP 4.5 scenario, and around 1.5 times higher than the 2008 level under the OECD, SSP 1/RCP 1.9 scenario (temperature rise is smaller than that under RCP 4.5 scenario).

Table 4.2.1-1: Representative Concentration Pathways (RCPs) used in this study

RCP 4.5 (Middle-level stabilization scenario)	Radiative forcing level will be stabilized at 4.5 W/m <sup>2</sup> by the end of this century. It is likely that the future temperature rise will be suppressed to 2.5 °C or less.
RCP 2.6 (Low-level stabilization scenario)	Radiative forcing level will hit its peak and then lower to 2.6 W/m <sup>2</sup> around the end of this century. It is likely that the future temperature rise will be suppressed to 1.6 °C or less.
RCP 1.9	Radiative forcing level will be stabilized at 1.9 W/m <sup>2</sup> by the end of this century. It is likely that the temperature rise at the peak time will be suppressed to 1.5 °C or less. (This scenario is used in the IPCC’s special report on the impact of a global warming of 1.5 °C (2018).)

Table 4.2.1-2: Estimated Seaborne Trade (in tons) up to 2050  
(emissions in 2008 = 1, excluding passenger transport)

Scenario	2020	2030	2040	2050
OECD, SSP 1/RCP 4.5	1.44	1.65	1.82	1.91
OECD, SSP 1/RCP 2.6	1.42	1.56	1.57	1.66
OECD, SSP 1/ RCP 1.9	1.39	1.36	1.40	1.47

#### 4.2.1.3 Estimate of Seaborne Trade in Ton-Miles

Seaborne trade in ton-miles up to 2050 was estimated by multiplying the estimated seaborne trade in tons of each commodity by the average length of haul (in nautical miles) of the commodity. For the average distance travelled, data published by Clarksons were used.

#### 4.2.1.4 Estimate of Seaborne Trade in Ton-Miles by Ship Type and Size

Seaborne trade in ton-miles by ship type and by size were estimated by setting relationships between seaborne trade of each commodity in ton-miles and the type and size of ship transporting each commodity. This estimation is based on the classification of ship type and size in the Third IMO Greenhouse Gas Study 2014<sup>4</sup> and on ship activity status in 2008. Figure 4.2.1-1 portrays the estimated seaborne trade in ton-miles by ship type corresponding to OECD, SSP 1/RCP 4.5 scenario. The total of

<sup>4</sup> IMO, *Third IMO Greenhouse Gas Study 2014*, 2014

seaborne trade in 2050 for each ship type is estimated to reach nearly the double of the 2008 level, approximately 41 trillion ton-miles. Table 4.2.1-3 presents estimated seaborne trade in ton-miles by ship size for major ship types, including oil tankers, bulkers and container ships.

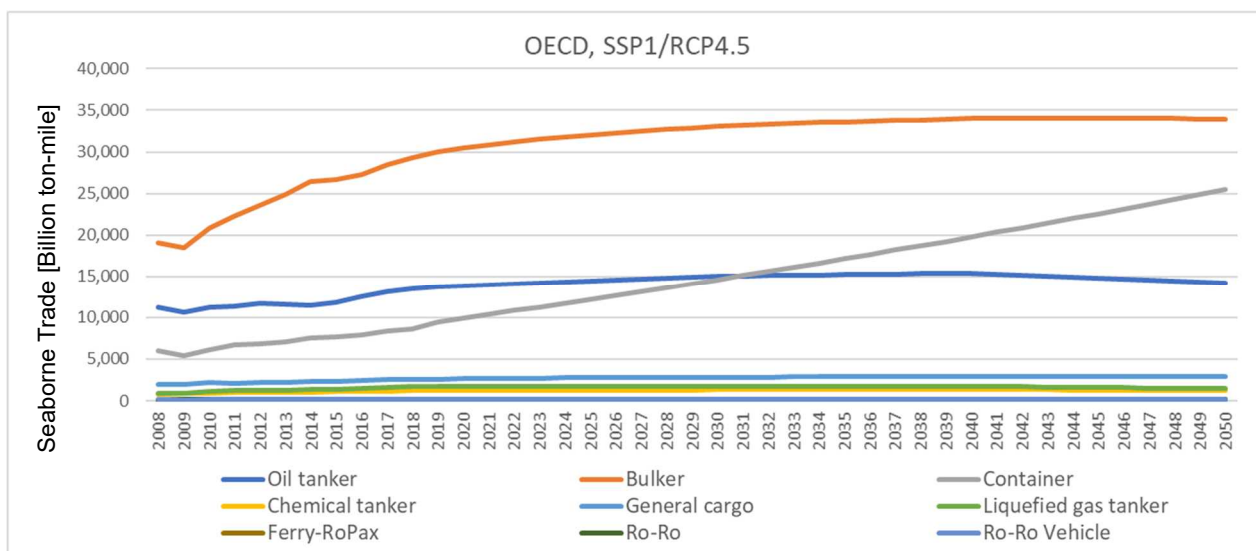

Figure 4.2.1-1: Estimated Seaborne Trade in ton-miles by Ship Type up to 2050  
(OECD, SSP1/RCP 4.5 scenario)

Table 4.2.1-3: Estimated Seaborne Trade in Ton-Miles by Size for Major Ship Types  
(OECD, SSP 1/RCP 4.5 scenario)

Ship type	Size	2008	2020	2030	2040	2050
Oil tanker	-4,999 dwt	127	161	176	181	166
	5k-9,999 dwt	72	91	99	102	93
	10k-19,999 dwt	76	96	105	108	99
	20k-59,999 dwt	1,082	1,368	1,497	1,542	1,409
	60k-79,999 dwt	940	1,188	1,300	1,339	1,224
	80k-119,999 dwt	3,219	4,070	4,453	4,588	4,191
	120k-199,999 dwt	1,391	1,664	1,805	1,845	1,727
	200k+ dwt	4,312	5,157	5,596	5,720	5,353
Bulkier	-9,999 dwt	131	198	218	225	226
	10k-34,999 dwt	3,516	5,309	5,825	6,008	6,038
	35k-59,999 dwt	6,402	9,667	10,607	10,940	10,994
	60k-99,999 dwt	4,150	6,935	7,543	7,863	7,805
	100k-199,999 dwt	3,893	6,681	7,078	7,148	7,108
	200k+ dwt	985	1,690	1,791	1,808	1,798
Container	-999 teu	228	379	556	754	973
	1k-1,999 teu	659	1,095	1,609	2,180	2,813
	2k-2,999 teu	724	1,203	1,767	2,395	3,090
	3k-4,999 teu	1,781	2,958	4,346	5,890	7,599
	5k-7,999 teu	1,644	2,731	4,012	5,438	7,016
	8k-11,999 teu	892	1,481	2,176	2,949	3,805
	12k-14,499 teu	54	90	133	180	232

In units of one billion ton-miles

## 4.2.2 Estimate of GHG Emissions in Business-As-Usual (BAU) Scenario: Continued Use of Conventional Technologies and Fuels

BAU emissions from international shipping was estimated by multiplying seaborne trade in ton-miles by ship type and size from 2020 to 2050 calculated in section 4.2.1 by CO<sub>2</sub> emissions of each ton-mile of seaborne trade by ship type in 2008. As already mentioned in section 4.1, BAU emissions in this report refer to future CO<sub>2</sub> emissions on the following assumptions: 1) no CO<sub>2</sub> emissions reduction measures will be taken after 2008; 2) the mode of marine transport (ship speed, ship type and size distribution, etc.), design technologies, fuels and other factors will be maintained; and 3) average energy efficiency will remain unchanged. In this study, the year 2008 was used for the base year in line with those used for the 2030 and 2050 targets in the IMO Strategy. Table 4.2.2-1 shows CO<sub>2</sub> emissions in 2008 per ton-mile by ship type. They were calculated based on the results of the IMO's Third IMO Greenhouse Gas Study and seaborne trade data supplied by Clarksons.

Table 4.2.2-1: CO<sub>2</sub> Emissions in 2008 per Ton-Mile by Ship Type

	Seaborne trade (B Tonmile/yr)	CO <sub>2</sub> emissions (M ton/yr)	Carbon Intensity (g-CO <sub>2</sub> /Tonmile)
Bulk carrier	19077	194.1	10.17
Chemical tanker	821	61.5	74.88
Container	5983	213.6	35.69
General cargo	1996	101.3	50.76
Liquefied gas tanker	901	35.7	39.60
Oil tanker	11219	159.8	14.25
Other liquids tankers	165	0.9	5.25
Ferry - pax - only	80	1.3	16.13
Cruise	509	29.4	57.81
Ferry - ro-pax	106	44.5	421.69
Refrigerated bulk	1243	20.9	16.81
Ro-ro	144	29.9	207.22
Ro-Ro Vehicle	160	28.1	175.73
<i>Total</i>	42404	920.9	21.72

Figure 4.2.2-1 portrays the results of the calculation of BAU emissions under the three scenarios mentioned in section 4.2.1. The results are shown with a Y-axis in which 1.0 represents the 2008 level. In the OECD, SSP 1/RCP 4.5 scenario, characterized with the largest increase in seaborne trade, the emissions in 2050 will be 2.29 times the 2008 level. In the OECD, SSP 1/RCP 2.6 scenario, emissions will be 2.13 times the 2008 level, and in the OECD, SSP 1/REC 1.9 scenario, they will be 1.97 times the 2008 level.

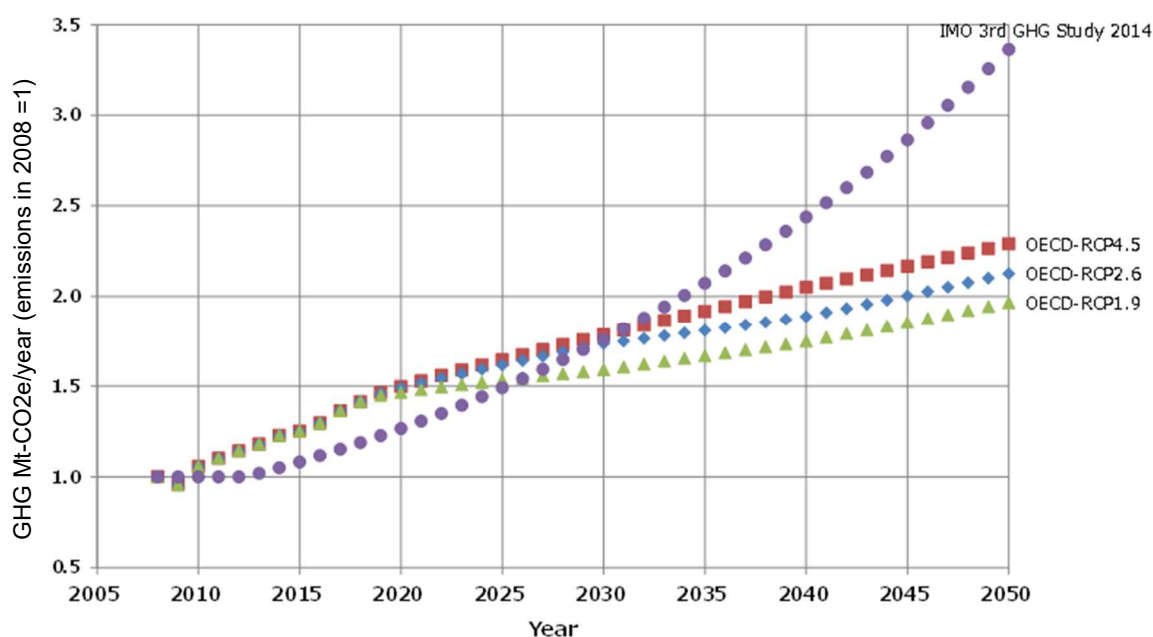

Figure 4.2.2-1: GHG Emissions from International Shipping by Climate Change Scenario (the emissions in 2008 = 1)

### 4.2.3 Reduction in GHG Emissions and Carbon Intensity Required to Achieve the 2050 Target

Required reduction in GHG emissions and carbon intensity to meet the 2050 target were calculated with the base line of the BAU emissions under the OECD, SSP 1/RCP 4.5 scenario, in which the projected GHG emissions are the largest among the three future scenarios mentioned in section 4.2.2. This scenario was chosen in order not to underestimate the GHG reduction efforts required. Table 4.2.3-1 shows the results for CO<sub>2</sub> emissions. The required CO<sub>2</sub> emissions reduction represents the difference between BAU emissions in 2050 and the maximum emissions level meeting the 2050 target, namely 460.5 million tons per year representing 50% of the emissions in 2008. The required CO<sub>2</sub> emissions reduction from international shipping in 2050 surpasses the total CO<sub>2</sub> emissions from land-based activities in Japan, 1,139 million tons in 2018.<sup>5</sup>

Table 4.2.3-1: GHG Reduction and Carbon Intensity<sup>6</sup> Reduction Required to Achieve the 2050 Target

	BAU emissions (M tons - CO <sub>2</sub> /year)	Required emissions reduction from BAU (ΔM tons - CO <sub>2</sub> /year)	Required reduction in carbon intensity (from 2008 level)
2050	2108.3	1647.8	78.2%

<sup>5</sup> Ministry of the Environment: *Japan's National Greenhouse Gas Emissions in Fiscal Year 2018 (Preliminary Figures)*, <http://www.env.go.jp/press/107410.html>.

<sup>6</sup> Calculated by dividing total CO<sub>2</sub> emissions by total seaborne trade.



## **Section 4.3: Emission Pathways for Achieving the 2050 Target and Beyond**

### **4.3.1 Feasibility Study on Potential Fuels and Technological Options**

#### **4.3.1.1 Feasibility of Alternative Fuels and GHG Reduction Technologies**

Introduction of alternative fuels and other technological solutions would be main options to reduce GHG emissions from international shipping. Alternative fuels that could be used to achieve the 2050 target include hydrogen, ammonia, LNG, synthetic carbon-recycled fuels and biofuels. Table 4.3.1-1 shows their respective physical properties, advantages and challenges. Other GHG emissions reduction technologies than the use of alternative fuels include wind propulsion, battery propulsion and onboard CO<sub>2</sub> capturing. Table 4.3.1-2 summarizes their characteristics. (For more detailed study results, refer to **Appendix 2.**)

Table 4.3.1-1: Main Physical Properties, Advantages and Disadvantages of Alternative Fuels

	CO <sub>2</sub> emissions per unit of heat <sup>1</sup> (HFO=1)	Liquid Fuel volume per unit of heat <sup>1</sup> (HFO=1)	Advantages	Disadvantages
<b>Hydrogen (H<sub>2</sub>) (including use in fuel cells)</b>	0	4.46	<ul style="list-style-type: none"> <li>- No CO<sub>2</sub> emissions onboard</li> <li>- Used in small boats (hydrogen-mixed fuel combustion engine, fuel cell)</li> <li>- Used in onshore boilers and gas turbines</li> </ul>	<ul style="list-style-type: none"> <li>- Large fuel volume, approx. 4.5 times that of HFO</li> <li>- Technical difficulty in storage stability (-253 °C in liquid state)</li> <li>- Bunkering infrastructure yet to be developed</li> <li>- Immaturity of bunkering technologies</li> <li>- Technical difficulties in combustion control</li> </ul>
<b>Ammonia</b>	0 (N <sub>2</sub> O emissions not considered)	2.72	<ul style="list-style-type: none"> <li>- No CO<sub>2</sub> emissions onboard</li> <li>- Used for combustion in gas turbines</li> </ul>	<ul style="list-style-type: none"> <li>- Large fuel volume, which is approx. 2.7 times that of HFO</li> <li>- NO<sub>x</sub> emissions</li> <li>- N<sub>2</sub>O emissions (its greenhouse effect approx. 300 times stronger than that of CO<sub>2</sub>)</li> <li>- Toxic</li> <li>- Technical challenges in combustion, such as low flammability (without pilot fuels) and difficulties in increasing engine output</li> </ul>
<b>LNG</b>	0.74 (methane slip not considered)	1.65	<ul style="list-style-type: none"> <li>- Already in practical use</li> <li>- Higher in volumetric energy density than hydrogen and others</li> <li>- Minor infrastructure upgrade for synthetic methane and biomethane</li> <li>- Specific regulations for LNG in the IGF Code</li> </ul>	<ul style="list-style-type: none"> <li>- Reduction of CO<sub>2</sub> emissions is limited.</li> <li>- Methane slip</li> <li>- Possible international criticism for the use of fossil fuels</li> </ul>
<b>Methane (CH<sub>4</sub>)</b>	0.71 [0 <sup>2</sup> ] (methane slip not considered)	1.80	<ul style="list-style-type: none"> <li>- Biomethane is treated as carbon neutral under the IPCC Guidelines in use phase.</li> <li>- Technologically feasible as chemically identical to LNG (predominantly methane) already in practical use - Infrastructure for LNG can be used.</li> </ul>	<ul style="list-style-type: none"> <li>- At present, the IPCC Guidelines have no explicit provision defining carbon-recycled methane as carbon neutral.</li> </ul>
<b>Biodiesel</b>	[0]	(1.2 or less)	<ul style="list-style-type: none"> <li>- Biodiesel is treated as carbon neutral under the IPCC Guidelines in use phase.</li> <li>- Combustion with other fuel is at commercial level onshore.</li> </ul>	<ul style="list-style-type: none"> <li>- Technical difficulties in storage stability</li> <li>- Possible low availability for shipping due to high demand in other sectors</li> </ul>
<b>Methanol (CH<sub>3</sub>OH)</b>	0.90 [0 <sup>2</sup> ]	2.39	<ul style="list-style-type: none"> <li>- Biomethanol is treated as carbon neutral under the IPCC Guidelines in use phase.</li> <li>- Methanol-fueled ships have already been delivered.</li> <li>- Easy to handle</li> </ul>	<ul style="list-style-type: none"> <li>- At present, the IPCC Guidelines have no explicit provision defining carbon-recycled methane as carbon neutral.</li> <li>- Large fuel volume, approx. 2.4 times that of HFO</li> <li>- Technical difficulties in ignitability and in increasing engine output</li> </ul>
<b>Ethanol (C<sub>2</sub>H<sub>5</sub>OH)</b>	0.93 [0 <sup>2</sup> ]	1.79	<ul style="list-style-type: none"> <li>- Bioethanol is treated as carbon neutral under the IPCC Guidelines in use phase.</li> <li>- Bioethanol production is at a commercial level.</li> <li>- Easy to handle</li> </ul>	<ul style="list-style-type: none"> <li>- At present, the IPCC Guidelines have no explicit provision defining carbon-recycled methane as carbon neutral.</li> <li>- Technical difficulties in ignitability and in increasing engine output</li> </ul>

1. CO<sub>2</sub> emissions per unit of heat and fuel volume (in the liquefied state) per unit heat were calculated on the basis of heavy oil for ships (HFO) with the lower heating value of 40.4 MJ/kg, the CO<sub>2</sub> conversion factor Cf= 3.114 t-CO<sub>2</sub>/t-Fuel and the specific gravity of 0.94. CO<sub>2</sub> emissions per unit of heat was calculated on the basis of the lower heating value of each fuel presented in the IPCC Guidelines and in the IMO's EEDI Calculation Guidelines.<sup>7</sup>

2. CO<sub>2</sub> emissions generated are counted as 0 (zero) when burning carbon-recycled fuels (artificially produced fuels by separating, capturing, and recycling CO<sub>2</sub>) and biofuels.

3. With respect to the space required in design, factors other than the fuel volume also need to be taken into account for each of these fuels.

<sup>7</sup> 2018 GUIDELINES ON THE METHOD OF CALCULATION OF THE ATTAINED ENERGY EFFICIENCY DESIGN INDEX (EEDI) FOR NEW SHIPS (MEPC.308(73))

Table 4.3.1-2: Characteristics of GHG Reduction Technologies

	Potential for efficiency improvement	Advantage	Disadvantage
<b>Wind propulsion</b>	Dependent on the extent of use	- Zero emissions onboard	- It cannot be used as a main source for propulsion for reasons of scale.
<b>Solar cells</b>	Dependent on the extent of use	- Zero emissions onboard	- It cannot be used as a main source for propulsion for reasons of scale.
<b>Air lubrication</b>	Around 2% to 6%	- Technologies available	- The effect varies depending on the hull form and the operation status.
<b>Low friction paints</b>	Around 2% to 5%	- Technologies available	- The effect varies depending on the hull form and the operation status.
<b>Energy efficient ducts</b>	Around 2% to 5%	- Technologies available	- The effect varies depending on the hull and stern forms and the operation status.
<b>Bow form change</b>	Around 2% to 5%	- Technologies available	- The effect varies depending on the hull and bow forms and the operation status.
<b>Exhaust heat recovery system for generation of electricity</b>	Around 1% to 5%	- Technologies available	-
<b>Battery propulsion</b>	Dependent on the extent and method of use	- Zero emissions onboard - Implemented as the main propulsion system in some small boats and as an auxiliary propulsion system in some larger ships	- Low weight and volumetric energy density - High voltage recharging infrastructure underdeveloped - Longer charging time required than conventional fuel bunkering
<b>Onboard CO<sub>2</sub> capturing</b>	Capturing at least 85% of CO <sub>2</sub> in exhaust gas	- Compatible with any fuel oil/gas (in theory) - Reduction at a considerable rate (in theory)	- No track record of implementation onboard - Exhaust gas pre-treatment (such as denitration and desulfurization) required depending on the type of fuel - Large volume and weight of CO <sub>2</sub> after capturing

#### 4.3.1.2 Identification of Appropriate Alternative Fuels and Technologies

According to the results in Section 4.2, it is necessary to improve the average energy efficiency of international shipping (GHG emissions per ton-mile) by around 80% or more compared to the 2008 level by the year of 2050 in order to meet the 2050 target set out in the IMO Strategy. Therefore, it is necessary to start introducing 80% or more efficient ships from around 2030, on a simplified assumption that ocean-going ships have a service life of 20 years. If they have a longer life, efforts should be made towards introducing ships with 90% or greater efficiency improvement by 2030. Japan, as one of the major players in global shipping and shipbuilding sector, should endeavor aiming at introduction of such ultra-low or zero emission ships even earlier than 2030.

In addition, measures taken to achieve the 2050 target should be part of holistic framework/approach that leads to the achievement of the longer-term target, namely zero GHG emission as early as possible in this century.

In light of the matters discussed above, potential alternative fuels and technological options that should be pursued, in addition to currently available fuels, technical and operational improvements, were narrowed down based on the following criteria, and GHG emission pathways to achieve the long-term targets were developed accordingly.

< Short list criteria>

- Have a potential to improve energy efficiency by 90% or more compared to the 2008 level by 2028.
- Capable of achieving zero emissions from international shipping in the long term.

Table 4.3.1-3 shows the potential options identified. In this table, options in green were deemed to have the highest potential for practical realization by 2028, and those in yellow were considered to have high potential for practical realization by 2028, while all having some technological challenges to overcome.

The options meeting the aforementioned criteria with the highest potential include hydrogen-fueled ships (direct combustion with liquefied hydrogen), ammonia-fueled ships (direct combustion), ships using carbon-recycled methane (synthetic fuel), and relatively large ships equipped with onboard CO<sub>2</sub> capturing systems. Here, the carbon-recycled methane refers to methane produced from hydrogen and captured CO<sub>2</sub>.

As liquefied hydrogen and ammonia fuel both emit no CO<sub>2</sub> when burnt with no pilot fuel, those fuels have a large potential to play an important role to reduce the total GHG emissions from international shipping sector. Although there are some technical issues to be resolved as mentioned earlier, the developments of internal combustion engines for those fuels are expected to be accelerated, and it is deemed possible to introduce ships with such engines by 2028.

Table 4.3.1-3: Alternative Fuel and Technological Options for Achieving the Long-Term Target

	Coastal ships: Estimated cruising range of 200 miles (e.g. Tokyo-Tomakomai)	Short-distance ocean-going ships: Estimated cruising range of 1,000 miles (e.g. Japan-China)	Medium-distance ocean-going ships: Estimated cruising range of 3,000 miles (e.g. Japan-Singapore)	Long-distance ocean-going ships: Estimated cruising range of 5,000 miles (e.g. Japan-LA/LB)
Battery propulsion ships	- Pod drive - Cruising range may be increased to around 200 miles.	- Difficulties due to low energy density of batteries		
Hydrogen-fueled ships (liquefied hydrogen, direct combustion)	-Development of technologies for fuel supply systems is required. -R&D for internal combustion engines using hydrogen has been started.		-Potential application to ships with short cruising ranges	
Hydrogen-fueled ships (liquefied hydrogen, fuel cells)	-Technological development of carburetors is needed. - Poor load-following capability and slow startup of fuel cells -It is possible to combine with small-capacity batteries. -For large ships, a high output motor needs to be developed.			
Hydrogen-fueled ships (hydrogen energy carrier, direct combustion & fuel cells)	-Technical challenges and potential are same as hydrogen-fueled ships (liquefied hydrogen, direct combustion and fuel cells). -Technological development for separators is quite challenging. -A space for the separator is required (there is no reason to use energy carrier instead of hydrogen). -For large ships powered by fuel cells, it is necessary to develop a high output motor.			
Ammonia-fueled ships (direct combustion)	-Ammonia has poor combustibility. -Measures against N <sub>2</sub> O emissions are required.		-R&D for two-cycle engines has been started.	
Ammonia-fueled ships (fuel cells)	- Technologically premature compared to direct combustion type			
Ships using carbon-recycled methane	-Technology for LNG-fueled ships could be applied. -Explicit methodology for accounting GHG emissions from carbon-recycled methane not developed. Necessary to be considered as carbon neutral in use phase. -Measures against methane slip are required.			
Onboard CO <sub>2</sub> capturing	-Onboard CO <sub>2</sub> storage space necessary (particularly barrier for small ships) -Capture rate should be increased. -Onshore CO <sub>2</sub> reception facilities (storage, recycling) need to be developed.	-Onboard CO <sub>2</sub> storage space necessary -Capture rate should be increased. -Onshore CO <sub>2</sub> reception facilities (storage, recycling) need to be developed.		

Note 1: This table does not take into account the availability of fuel supply.

Note 2: If hydrogen or ammonia is used as fuel, rules on ship safety and seafarers must be reviewed.

Note 3: Hydrogen energy carriers are substances that carry and store hydrogen. Here, hydrogen storing alloys, organic hydride and other substances excluding liquefied hydrogen and ammonia are presumed to be used as carriers.

With regard to carbon-recycled methane, since technologies for liquefied natural gas (LNG) that are already in practical use are applicable, existing LNG-fueled ships and bunkering infrastructure can be used without any upgrade, given that methane is the main ingredient making up around 90% of LNG. However, it must be noted that carbon-recycled methane produced from captured CO<sub>2</sub> need to be internationally recognized and verified as carbon neutral fuel and that measures against methane slip have to be taken so that a ship using such fuel becomes an ultra-low or zero emission ship.

Regarding onboard CO<sub>2</sub> capturing system, it is considered applicable to ocean-going ships as it is already in practical use in onshore facilities while it would be difficult to install on small ships due to their limited space for CO<sub>2</sub> storage. As this technology is applicable to ships using conventional fossil fuels, it has potential to achieve 90% or greater CO<sub>2</sub> emissions reduction without relying on fuel transition. However, further improvement of the CO<sub>2</sub> capture rate and the development of onshore CO<sub>2</sub> reception facilities are necessary.

In this study, fuel cells have been categorized as having relatively poor potential for practical application as a main source of propulsion power at the time of 2028 because there are large barriers to their application in large ships. For hydrogen energy carriers other than liquefied hydrogen and ammonia, potential of their use as a marine fuel would be low for the time being in terms of volumetric efficiency and the technological issues of separators. Therefore, ships using these carriers were removed from the short-list of technologies.

A number of research and development activities are undertaken for technologies to utilize alternative fuels. At this stage, it is difficult to accurately estimate the superiority of each alternative fuel and technologies discussed above and how large the uptake of each fuel and technology will be in the future. Therefore, it would be necessary to carry out more detailed studies at a later stage, while monitoring the trend of energy supply and price, and the development of new technologies.

#### **4.3.2 Emission Pathways for Achieving the 2050 Target and beyond**

In sub section 4.3.1.2, alternative fuels, such as hydrogen, ammonia, carbon-recycled methane produced from the captured CO<sub>2</sub>, and onboard CO<sub>2</sub> capturing technology were identified as technological options that are expected to be practically applied to ships by 2028 for achieving reduction of GHG emissions by 90% or more compared to the 2008 level, along with currently available fuels, technical and operational improvements. Taking into account these shortlisted options, GHG emission pathways were developed to meet the 2050 target in the IMO Strategy.

Given that the aforementioned alternative fuels and technologies may be introduced in or after 2028, LNG fuels alone are the only practicable option to address GHG emissions reduction by means of fuel transition in international shipping for the time being. It is therefore considered that the expansion of the use of LNG fuels will be a common trend to all emission pathways. On the basis of this trend, two major possibilities of fuel shift in international shipping are examined. One is the possibility of the expanded use of biomethane or carbon-recycled methane using the infrastructure for LNG fuels that have been already widely used as a marine fuel. The other is the possibility of increased use of either hydrogen or ammonia fuels, or both, which generate no CO<sub>2</sub> at all when burnt, in addition to the continuous use of LNG fuels. Considering these possibilities of fuel transition, following two GHG emission pathways are examined.

- **Emission pathway I “a fuel shift from LNG to carbon-recycled methane”**
- **Emission pathway II “the expansion of hydrogen and/or ammonia fuels”**

Based on the findings in 4.3.1, Figure 4.3.2-1 shows assumed timeline for the introduction of alternative fuels and other technologies considered in the two emission pathways. As discussed in 4.3.1.2, it was envisioned that hydrogen fuels, ammonia fuels and onboard CO<sub>2</sub> capturing technology would be introduced from 2028 onwards. It was also presumed that as more and more LNG-fueled ships are used, the newbuilding of ships using petroleum-based fuel such as heavy fuel oil would gradually decrease and that no such ships would be built in or after 2035.

In Figure 4.3.2-2, the project examined the penetration levels of the different alternative fuels and technologies and other assumptions for two different pathways in 2050, which enable global shipping sector to achieve the 2050 target under the conditions specified in Figure 4.3.2-1.

In both pathways, it is expected that the 2030 target of carbon intensity reduction by 40% will be achieved, followed by an extra 5% reduction by means of technical and operational improvement by 2050, and that nearly 2% of the entire fleet engaged in international shipping will adopt wind or battery propulsion.

In the emission pathway shifting from LNG to carbon-recycled methane, it is assumed that construction of infrastructure for hydrogen and ammonia fuels will not advance considerably despite the increased use of LNG-fueled ships and the expansion of infrastructure for supplying LNG fuels. In this case, nearly 75% of energy consumption in international shipping in 2050 will be supplied by LNG fuels, carbon-recycled methane, or biomethane fuels while around 10% will be by hydrogen or ammonia fuels. In addition, some 20% of the LNG-fueled ships will introduce onboard CO<sub>2</sub> capturing system. These set of measures enable the achievement of the 2050 target.

In the emission pathway of the expansion of hydrogen and ammonia fuels, it is assumed that the development of ship technology will be advanced and fuel supply will be increased for hydrogen or ammonia fuels, or for both. However, since the introduction of ships using these fuels is presumed to commence around 2028, it is considered more realistic to envision that the use of currently available LNG fuels will also increase to some extent. It will be possible to reach the 2050 target on the condition that hydrogen or ammonia fuels account for approximately 45% of energy consumption in international shipping in 2050 and LNG fuels some 35%, while carbon-recycled methane or biomethane fuels account for around 7%, and that nearly 5% of the ships of the international shipping sector will introduce onboard CO<sub>2</sub> capturing.

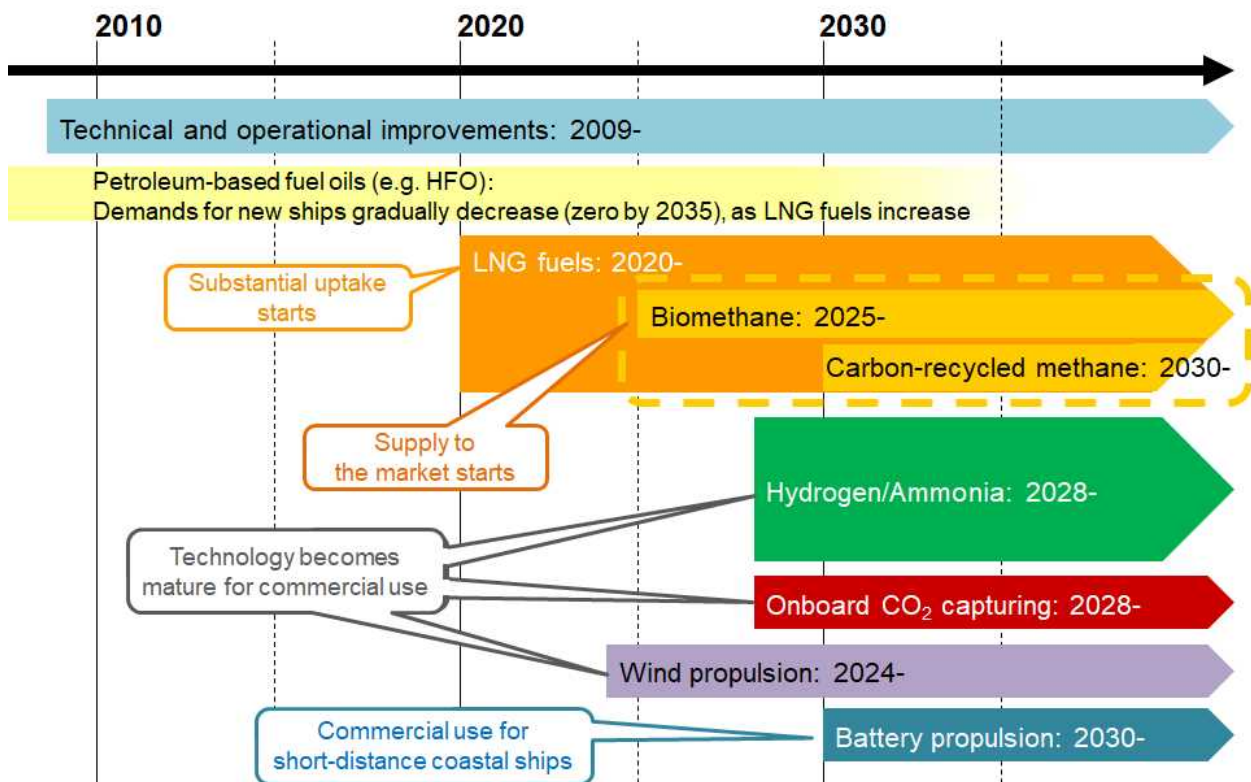

Figure 4.3.2-1: Timeline for the Introduction of Alternative Fuels and Technologies Used in Emission Pathways

1. LNG to Carbon-Recycled Methane		2. Expansion of Hydrogen / Ammonia	
<b>Technical and operational improvements</b>	<ul style="list-style-type: none"> <li>• efficiency improvement over the fleet at least 40% by 2030</li> <li>• efficiency improvement over the fleet at least 45% by 2030</li> </ul>		
<b>Use of petroleum fuel</b>	<ul style="list-style-type: none"> <li>• Supply for shipping sector gradually decreases by 2050 due to decreasing product volume in energy sector</li> <li>• Demands for new ships gradually decrease (zero by 2035), as LNG fuels increase</li> </ul>		
<b>LNG fuel</b>	<ul style="list-style-type: none"> <li>• Accounts for approx. 35% of energy consumed in international shipping in 2050</li> </ul>	<b>LNG fuel</b>	<ul style="list-style-type: none"> <li>• Accounts for approx. 35% of energy consumed in international shipping in 2050</li> </ul>
<b>Carbon-recycled methane / Biomethane</b>	<ul style="list-style-type: none"> <li>• Accounts for approx. 40% of energy consumed in international shipping in 2050</li> </ul>	<b>Carbon-recycled methane / Biomethane</b>	<ul style="list-style-type: none"> <li>• Accounts for approx. 7% of energy consumed in international shipping in 2050</li> </ul>
<b>Hydrogen / Ammonia</b>	<ul style="list-style-type: none"> <li>• Accounts for approx. 10% of energy consumed in international shipping in 2050</li> </ul>	<b>Hydrogen / Ammonia</b>	<ul style="list-style-type: none"> <li>• Accounts for approx. 45% of energy consumed in international shipping in 2050</li> </ul>
<b>Onboard CO<sub>2</sub> capturing</b>	<ul style="list-style-type: none"> <li>• Installed in approx. 20% of LNG-fueled ships in 2050.</li> </ul>	<b>Onboard CO<sub>2</sub> capturing</b>	<ul style="list-style-type: none"> <li>• Installed in approx. 5% of LNG-fueled ships in 2050.</li> </ul>
<b>Wind propulsion / Battery</b>	<ul style="list-style-type: none"> <li>• Introduced in approx. 2% of ships engaged in international shipping</li> </ul>		

Figure 4.3.2-2: Assumptions in Two Emission Pathways



In the following sections, GHG emission and fuel consumption trends in international shipping under the two emission pathways are shown.

#### **4.3.2.1 Emission Pathway I: A Fuel Shift from LNG to Carbon-recycled Methane**

Figures 4.3.2-3 and 4.3.2-4 demonstrate the trends in GHG emissions and reduction and energy consumption by fuel in the pathway of using mainly LNG fuels and carbon-recycled methane as a marine fuel.

In Figure 4.3.2-3, the top broken line indicates BAU emissions and the bottom solid line a trend in emissions that meets the targets for 2050 and beyond. The difference between these two lines represents GHG emissions reduction achieved by alternative fuels and technical and operational improvements. In this emission pathway, carbon-recycled methane will make the greatest contribution to GHG emissions reduction besides the reductions achieved by the introduction of energy saving technologies and operational improvements. In Figure 4.3.2-3, carbon-recycled methane and biofuels are treated under the same category (right orange) as both are carbon-neutral fuels. Because of uncertainty in supply of biofuels due to demand from other sectors, etc., the contribution of each carbon-neutral fuel was not quantitatively estimated.

With regard to LNG fuels, they make a limited contribution to GHG reduction (Figure 4.3.2-3) because, as shown in Table 4.3.1-1, LNG's CO<sub>2</sub> emissions per unit of heat is 74% of those of HFO. However, it should be pointed out that they constitute a large portion of energy consumption in international shipping (Figure 4.3.2-4) in 2050, and are significant in the sense that their widespread use will provide the foundation for the introduction of carbon-recycled methane and biomethane in 2025 and later years.

It should also be noted that this pathway is based on the assumption that carbon-recycled methane will be sufficiently supplied and that they will be recognized by the IMO or other bodies as carbon-neutral fuels.

#### **4.3.2.2 Emission Pathway II: Expansion of Hydrogen and/or Ammonia Fuels**

Figures 4.3.2-5 and 4.3.2-6 demonstrate the trends in GHG emissions and reduction and the energy consumption by fuel under the pathway in which hydrogen and/or ammonia fuels will be mainly used in international shipping. In this pathway, hydrogen or ammonia fuels will make the greatest contribution to GHG reduction besides reductions achieved by the introduction of energy saving technologies and operational improvements. As discussed in subsection 4.3.1.2, hydrogen and ammonia have their respective advantages and disadvantages and at this stage it is difficult to tell which of them is superior. This pathway, similar to another pathway mainly utilizing LNG and carbon-recycled methane, envisions that use of LNG fuels will expand.

It is to be noted that this pathway is based on the assumption that hydrogen and/or ammonia fuels will be sufficiently supplied.

**Emission pathway I “a fuel shift from LNG to carbon-recycled methane”**

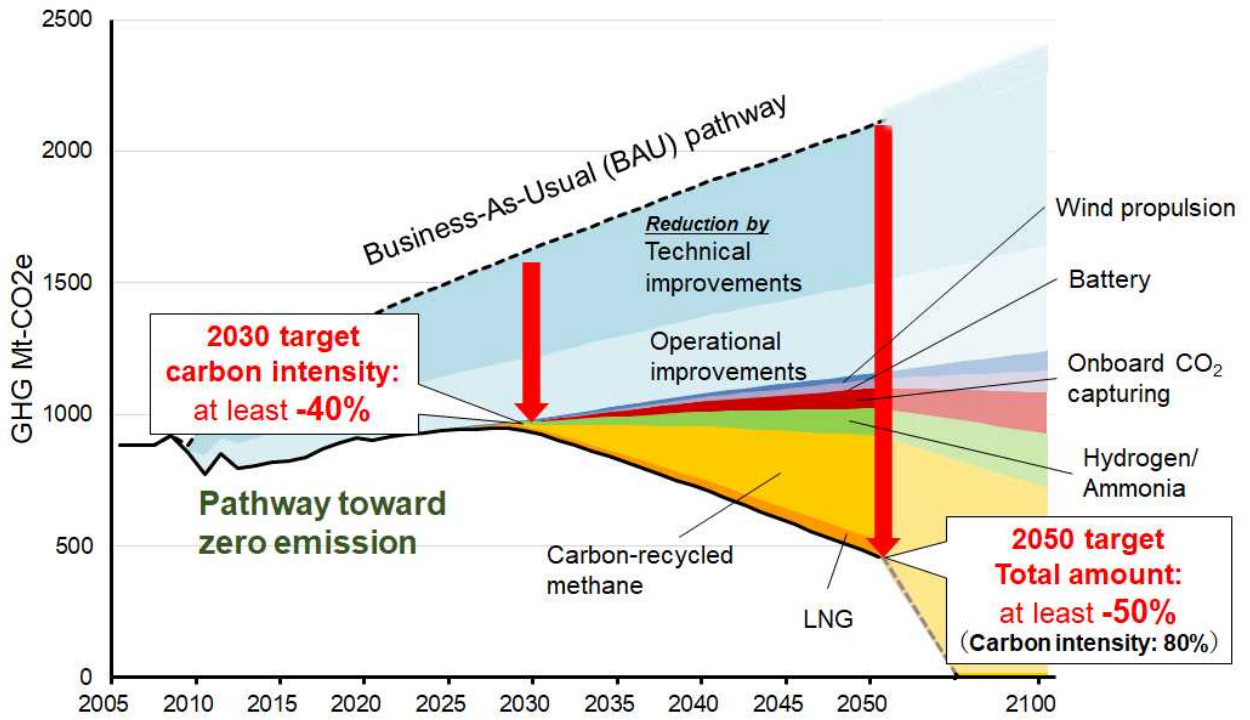

Figure 4.3.2-3: Trends in GHG Emissions and Reduction  
(Emission Pathway I: a Fuel Shift from LNG to Carbon-recycled Methane)

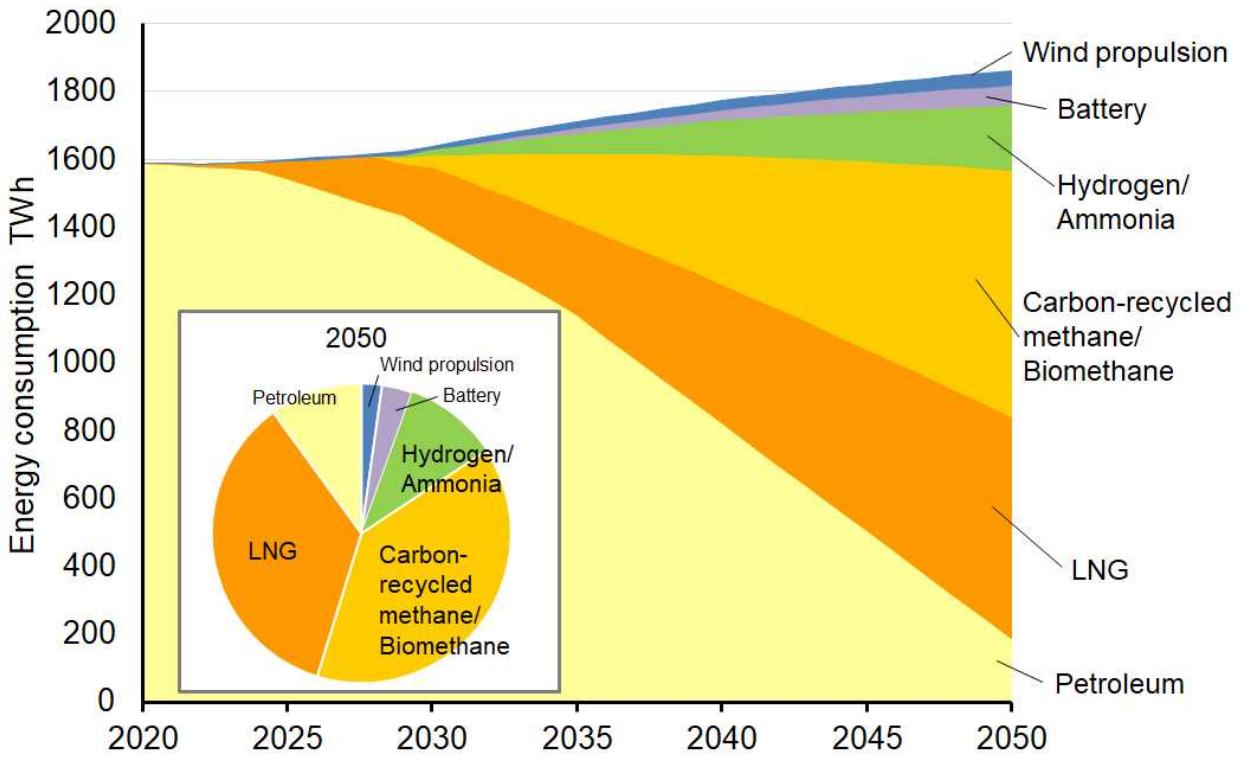

Figure 4.3.2-4: Energy Consumption by Fuel  
(Emission Pathway I: a Fuel Shift from LNG to Carbon-recycled Methane)

## Emission pathway II “the expansion of hydrogen and/or ammonia”

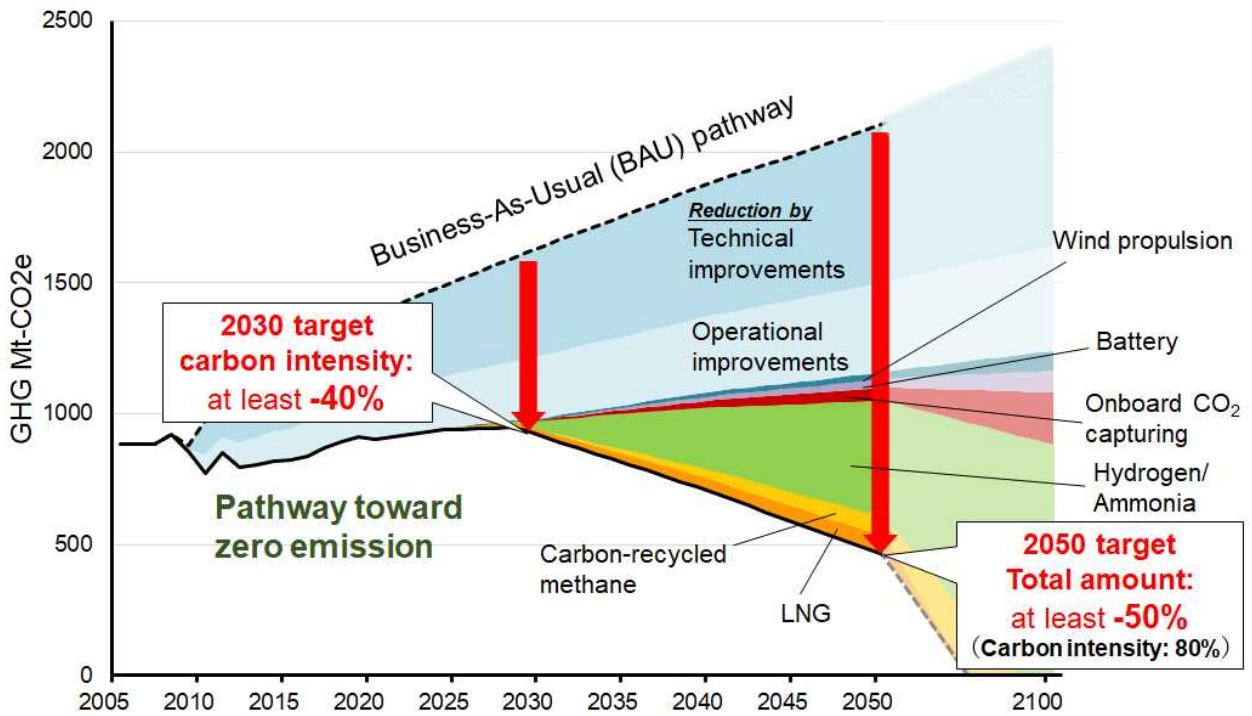

Figure 4.3.2-5: Trends in GHG Emissions and Reduction  
(Emission Pathway II: the Expansion of Hydrogen and/or Ammonia Fuels)

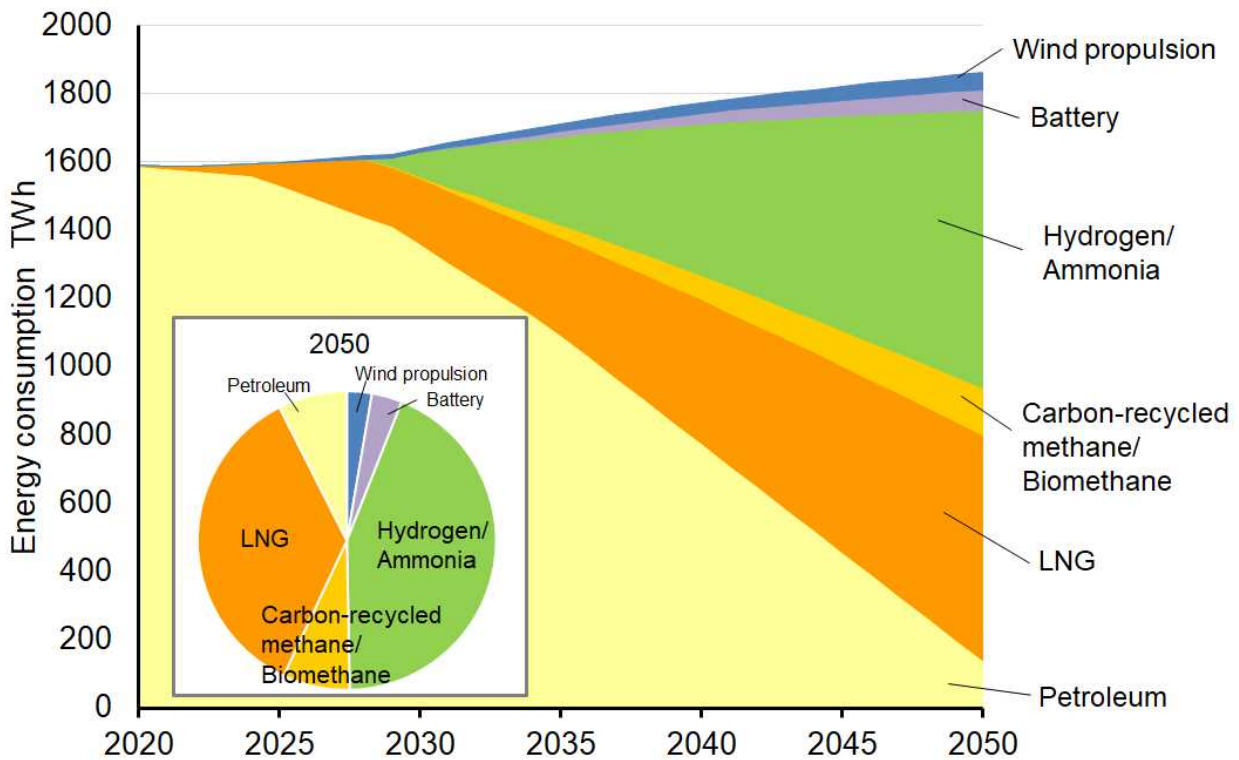

Figure 4.3.2-6: Energy Consumption by Fuel  
(Emission Pathway II: the Expansion of Hydrogen and/or Ammonia Fuels)

## **Section 4.4: Concept Designs for Ultra-low or Zero Emission Ships**

The Project created the concept designs for the ultra-low or zero emission ships achieving nearly or more than 90% reduction of GHG emissions compared to the 2008 level (hereafter “**Zero Emission Ships**”) to be introduced by 2028: (1) hydrogen-fueled ships, (2) ammonia-fueled ships, (3) onboard CO<sub>2</sub> capturing ships, and (4) super-efficient LNG-fueled ships. By developing the concept designs of these four types of Zero Emission Ships, envisioning 20,000 TEU container ships or 80,000 DWT bulk carriers, the Project identified possibilities as well as challenges in introducing the Zero Emission Ships from technical and other perspectives. (For details, refer to **Appendix 3.**)

### **4.4.1 Hydrogen-Fueled Ships**

The Project developed concept designs for two different sizes of liquified hydrogen-fueled ships, an 80,000 DWT bulk carrier and a 20,000 TEU container ship.

The designs were based on the assumption that i) liquefied hydrogen for the purpose of bunker fuel could be supplied at five major ports located around the world, in Europe, the Middle East, Australia, Japan and South America, that ii) the 80,000 DWT bulk carrier would have a one-way cruising range of 7,000 nautical miles (NM) while the 20,000 TEU container ship would have 11,500 NM, and that iii) a dual fuel reciprocating engine would be used as the main engine. Figures 4.4.1-1 and 4.4.1-3 show the general arrangements of these ships and Tables 4.4.1-1 and 4.4.1-2 show their principal characteristics.

In developing the concept design, the following technical issues which should be resolved in introducing the liquified hydrogen-fueled ships were identified: development of hydrogen-fueled engines and fuel supply systems, upsizing of fuel tanks, thermal protection systems, and measures to prevent hydrogen leakage. (**See Appendix 3-1.**)

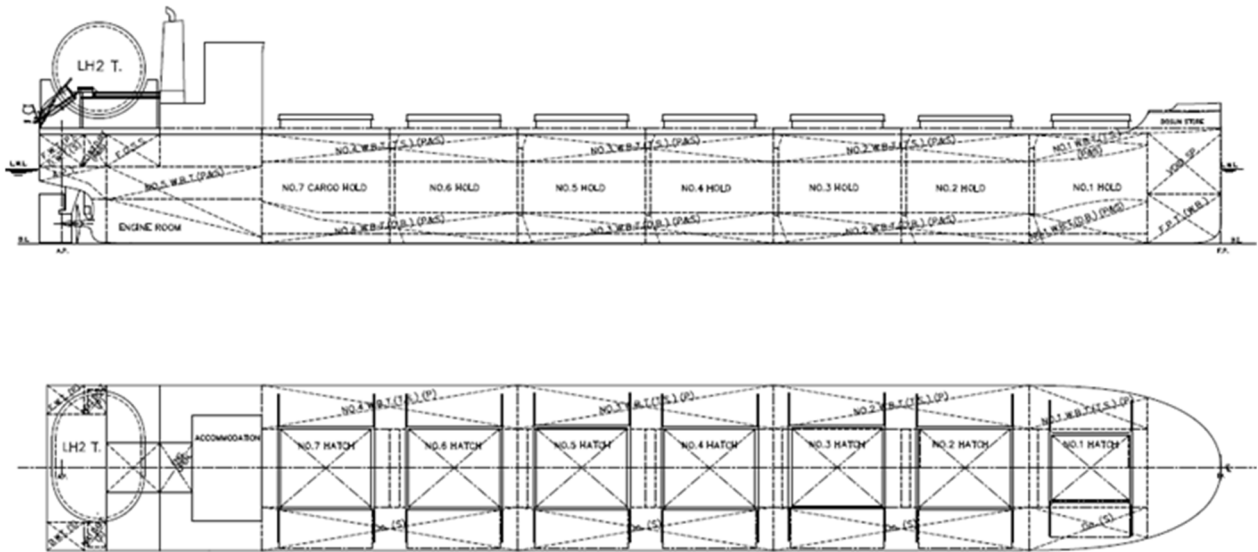

Figure 4.4.1-1: General Arrangement of the Hydrogen-Fueled 80,000 DWT Bulk Carrier

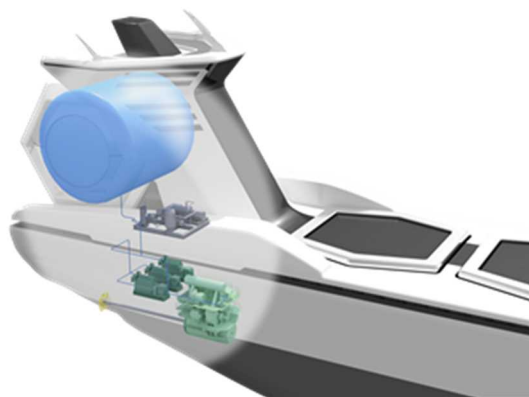

Figure 4.4.1-2: Hydrogen Fuel Systems on the 80,000 DWT Bulk Carrier

Table 4.4.1-1: Principal Characteristics of the Hydrogen-Fueled 80,000 DWT Bulk Carrier

Total length	228.9 m
Ship length	226.00 m
Total width	32.24 m
Depth	21.20 m
Draft	
Designed draft	12.20 m
Full load summer draft	14.50 m
Deadweight	
Designed draft	63,500 tons
Full load summer draft	80,000 tons
Liquefied hydrogen tank	4,000 m <sup>3</sup>
Designed speed	14.0 knots
Cruising distance	7,000 NM
Main engine	1 unit
Maximum output	8,000kW x 84 rpm
Normal output	6,800kW x 80 rpm
Power generator	3 units
	1,000 kW

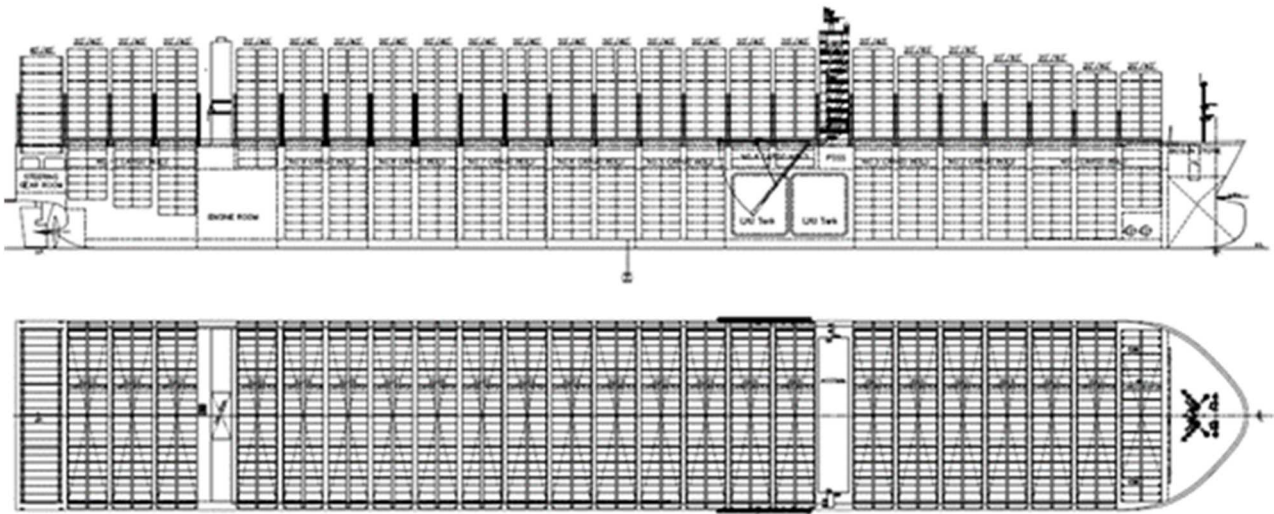

Figure 4.4.1-3: General Arrangement of the Hydrogen-Fueled 20,000 TEU Container Ship

Table 4.4.1-2: Principal Characteristics of the Hydrogen-Fueled 20,000 TEU Container Ship

Total length	399.90 m
Ship length	383.00 m
Total width	61.50 m
Depth	33.00 m
Draft	
Designed draft	14.50 m
Full load summer draft	16.50 m
Liquefied hydrogen tank	30,000 m <sup>3</sup>
Number of containers	21,000 TEUs
Freezing container plugs	1,100 TEUs
Designed speed	22.5 knots
Cruising distance	11,500 NM
Main engine	1 unit
Maximum output	60,000 kW x 80 rpm
Normal output	54,000 kW x 77 rpm
Power generator	3 units
	5,000 kW

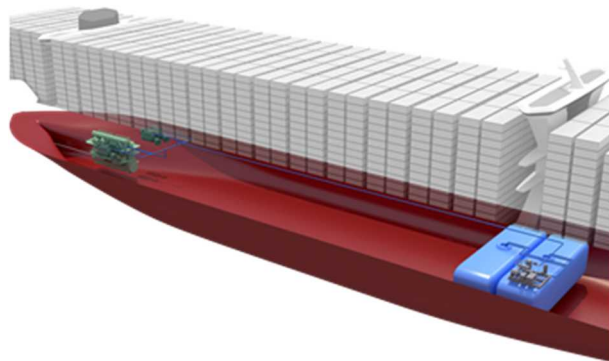

Figure 4.4.1-4: Hydrogen Fuel Systems on the 20,000 TEU Container Ship



## 4.4.2 Ammonia-Fueled Ships

The Project developed a concept design for an ammonia-fueled 80,000 DWT bulk carrier.

The design was based on the assumptions that i) the ship would serve Japan-Australia route, and that ii) a dual fuel reciprocating engine using a mechanism of injecting methanol, LPG or other liquid fuels as a pilot fuel would be used as a main engine. Given that ammonia fuels were flame-retardant, the engine was equipped with a pilot fuel injection valve to control ignition. With the pilot fuel considered, the ship was expected to reduce CO<sub>2</sub> by 91.9% compared to conventional ships of the same type and size. Figures 4.4.2-1 shows the general arrangement of the ship and Table 4.4.2-1 shows its principal characteristics.

In developing the concept design, the following technical issues which should be resolved in introducing the ammonia-fueled ships were identified: the risks of ammonia's toxicity and other properties, the control of ammonia leakage, release to the atmosphere in the event of an emergency, NO<sub>x</sub> emissions, N<sub>2</sub>O emissions and other issues. (See Appendix 3-2.)

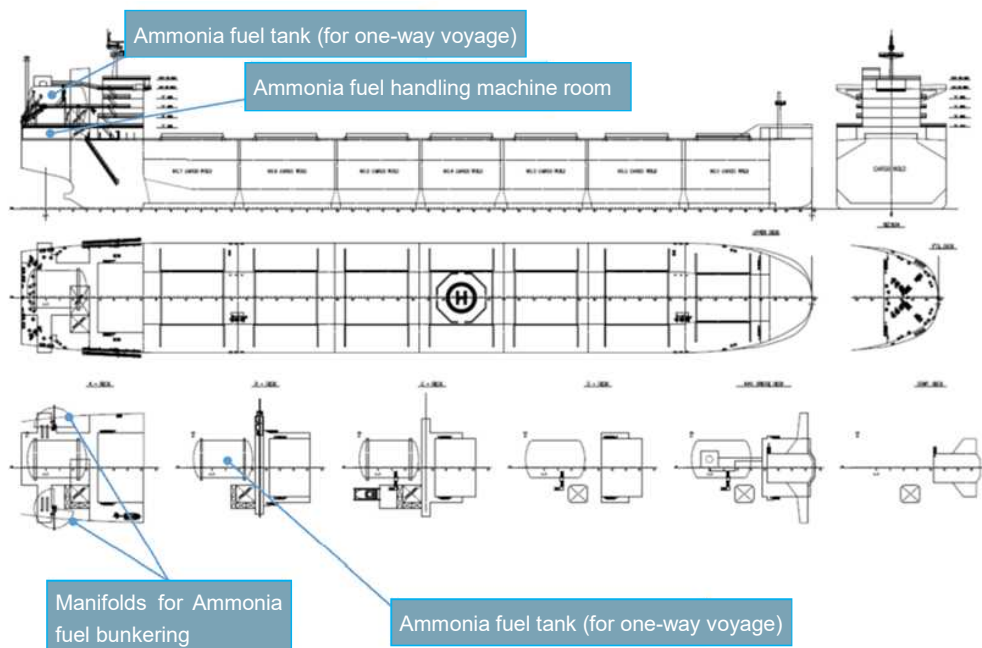

Figure 4.4.2-1: General Arrangement of the Ammonia-Fueled 80,000 DWT Bulk Carrier



Table 4.4.2-1: Principal Characteristics of Ammonia-Fueled 80,000 DWT Bulk Carrier

Total length	233.00 m
Ship length	225.5 m
Total width	32.26 m
Depth	20.10 m
Draft	
Designed draft	12.20 m
Full load summer draft	14.45 m
Deadweight	81,000 tons
Ammonia tank	1,550 m <sup>3</sup>
Designed speed	14.2 knots
Main engine	1 unit
Maximum output	9,660 kW
Normal output	7,052 kW
Power generator	3 units
	600 kW

Figure 4.4.2-2: Ammonia Fuel Related Systems

### 4.4.3 Onboard CO<sub>2</sub> Capturing Ship

The Project developed a concept design for a 20,000 TEU container ship equipped with an onboard CO<sub>2</sub> capturing system.

The design was based on assumptions that i) the ship would operate on routes between the Far East and Europe, that ii) a dual fuel reciprocating engine using methanol fuels would be used as main engine, and that iii) the ship is equipped with an onboard CO<sub>2</sub> capturing system using the liquid amine absorption method and CO<sub>2</sub> storage tanks. The systems are expected to capture 85.7% of CO<sub>2</sub> emissions, and has potential to improve the capturing rate to 90% or higher subject to further technological development. Figure 4.4.3-1 demonstrates the general arrangement of the ship and Table 4.4.3-1 its principal characteristics.

In developing the concept design, specific technical issues related to the CO<sub>2</sub> capturing and liquefaction systems which should be resolved in introducing the onboard CO<sub>2</sub> capturing ships were identified. (See **Appendix 3-3.**)

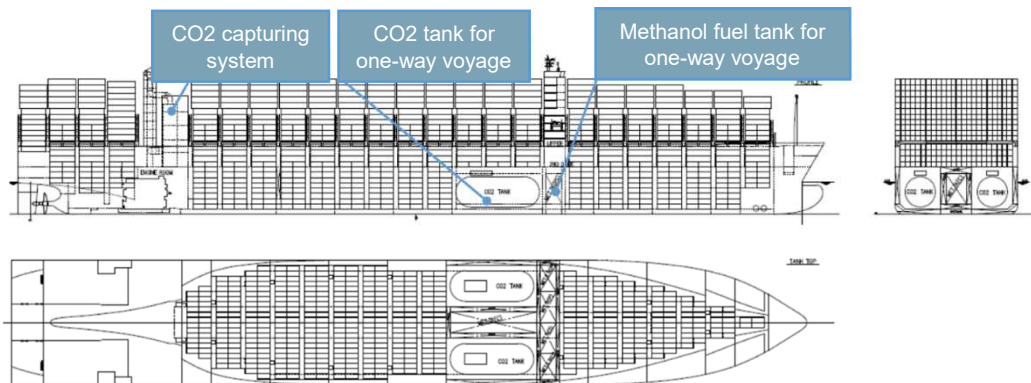

Figure 4.4.3-1: General Arrangement of 20,000 TEU Container Ship with an Onboard CO<sub>2</sub> Capturing System



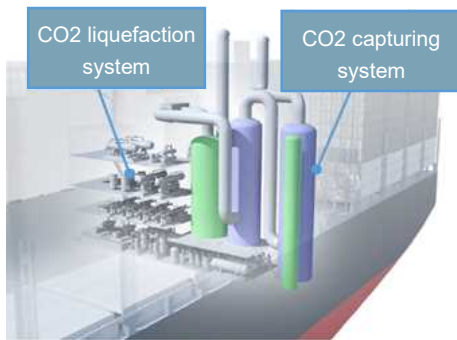

Figure 4.4.3-2: CO<sub>2</sub> Capturing and Liquefaction System

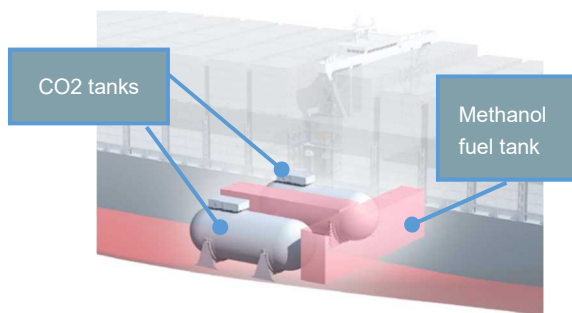

Figure 4.4.3-3: CO<sub>2</sub> and Methanol Fuel Tanks

Table 4.4.3-1: Principal Characteristics of 20,000 TEU Container Ship with an Onboard CO<sub>2</sub> Capturing System

Total length	399.90 m
Ship length	383.00 m
Total width	61.00 m
Depth	33.50 m
Draft	
Designed draft	14.50 m
Full load summer draft	16.00 m
Number of containers	21,300 TEUs
Methanol tank	13,200 m <sup>3</sup>
CO <sub>2</sub> tank	6,400 m <sup>3</sup> x 2 sets
Impact on loading capacity	-1,820 TEUs
Designed speed	21.8 knots
Main engine	1 unit
Maximum output	55,000 kW
Normal output	49,500 kW
Power generator	5 units
	6,870 kW

#### 4.4.4 Super-efficient LNG-Fueled Ships

The project developed concept designs for a bulk carrier and a container ship using a combination of LNG fuel and other technologies to achieve energy efficiency improvement by more than 80% compared to the 2008 level.

These designs assumed introduction of a hybrid contra-rotating propeller, hull form improvements, speed optimization, ship upsizing, electric propulsion and the application of LNG fuels and other innovative energy saving technologies, such as the wind propulsion system and the air lubrication system. In accordance with the IMO's EEDI calculation guidelines, these concept designs would achieve 86% improvement compared with the average efficiency of conventional ships. Figures 4.4.4-1 and 4.4.4-2 display general arrangements of the ships and Tables 4.4.4-1 and 4.4.4-2 their principal characteristics.

The technical challenges are considered to be few in the super-efficient LNG-fueled ships, as they are based on combination of currently available energy saving technologies. Meanwhile, it would be necessary to revise the IMO's related rules and guidelines in a bid to provide an environment for practical application. (See Appendix 3-4.)

Table 4.4.4-1: Principal Characteristics of the Super-efficient LNG-Fueled Bulk Carrier

Total length	229.00 m
Ship length	225.00 m
Total width	42.00 m
Depth	20.60 m
Draft	
Designed draft	12.20 m
Full load summer draft	14.45 m
Deadweight	102,000 tons
LNG tank	3,800 m <sup>3</sup>
Designed speed	11.5 knots
Propulsion motors	2 units
Rated output	1,750 kW

Figure 4.4.4-1(To be developed): General Arrangement of the Super-efficient LNG-Fueled Bulk Carrier

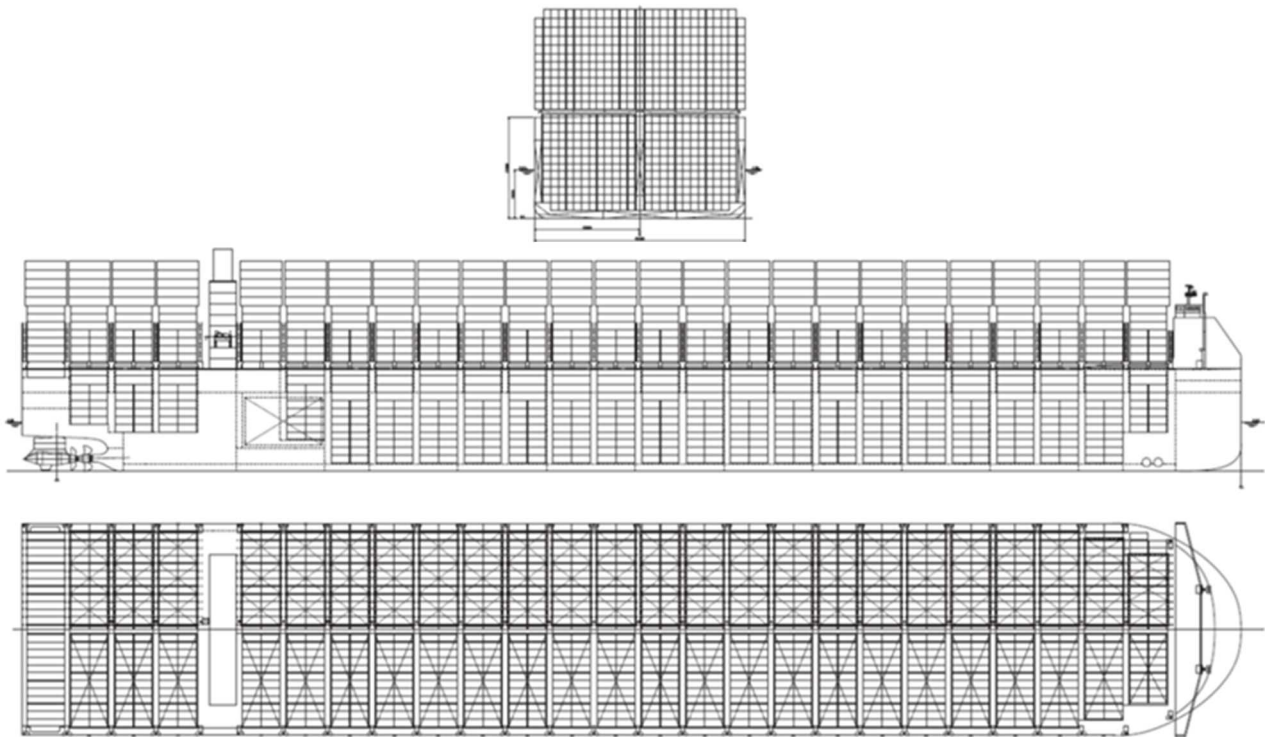

Figure 4.4.4-2: General Arrangement of the Super-efficient LNG-Fueled Container Ship

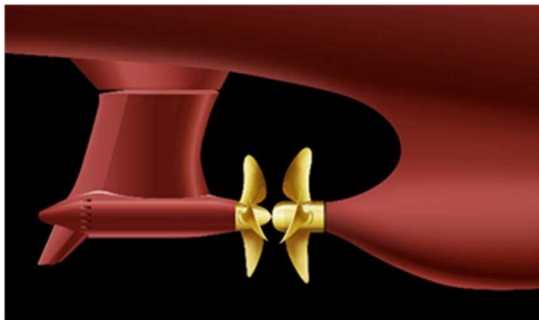

Figure 4.4.4-3: Hybrid Contra-Rotating Propeller System

Table 4.4.4-2: Principal Characteristics of the Super-efficient LNG-Fueled Container Ship

Total length	400.00 m
Ship length	387.00 m
Total width	69.20 m
Depth	33.20 m
Draft	
Designed draft	13.00 m
Full load summer draft	16.00 m
Number of containers	27,000 TEUs
LNG tank	11,000 m <sup>3</sup>
Designed speed	15.2 knots
Propulsion motors	2 units
Rated output	5,500 kW

### 4.4.5 Conceptual Drawings of Zero Emission Ships

Figure 4.4.5-1 shows conceptual drawings of each type of Zero Emission Ships.

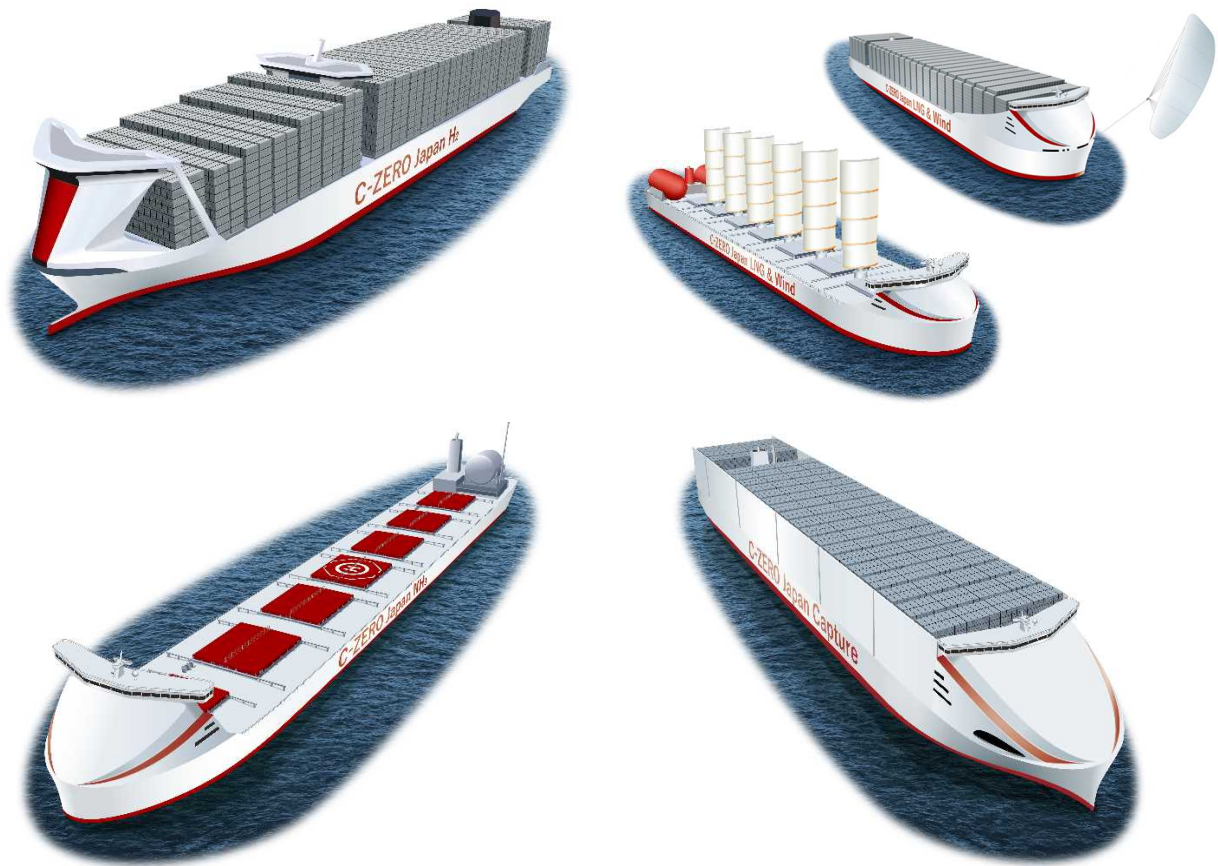

Figure 4.4.5-1: Bird's Eye Views of Zero Emission Ships

# Chapter 5: Roadmap to Zero Emission from International Shipping

## Section 5.1: Outline of the Roadmap

In Chapter 4, it was identified that energy efficiency improvement by 80% or more by 2050 compared to 2008 level would be needed in order to achieve the 2050 target of the IMO Strategy. Then the two emission pathways were developed: **Emission Pathway I “a fuel shift from LNG to carbon-recycled methane”** and **Emission Pathway II “expansion of hydrogen and/or ammonia fuels”**. On this basis, the Project considered actions which would need to be taken by the industrial, academic, and public sectors, as well as timelines for these actions. These actions and timelines are put together as a roadmap to zero emission from international shipping.

Figure 5.1-1 outlines the roadmap. It designates the period from 2028 to 2030 as the milestone to start introduction of Zero Emission Ships (ultra-low or zero emission ships capable of achieving nearly or more than 90% reduction of GHG emissions compared to the 2008 level) in order to achieve the 2050 target. To realize construction and operation of Zero Emission Ships by the milestone, research, development and demonstration of new technologies should be accelerated, and simultaneously regulatory framework and standards should be reviewed or developed at a global level. Then, it would also be necessary to develop measures to incentivize adoption of Zero Emission Ships, as well as global supply chains and infrastructures for low-/zero-carbon alternative fuel to facilitate wide spread of them.

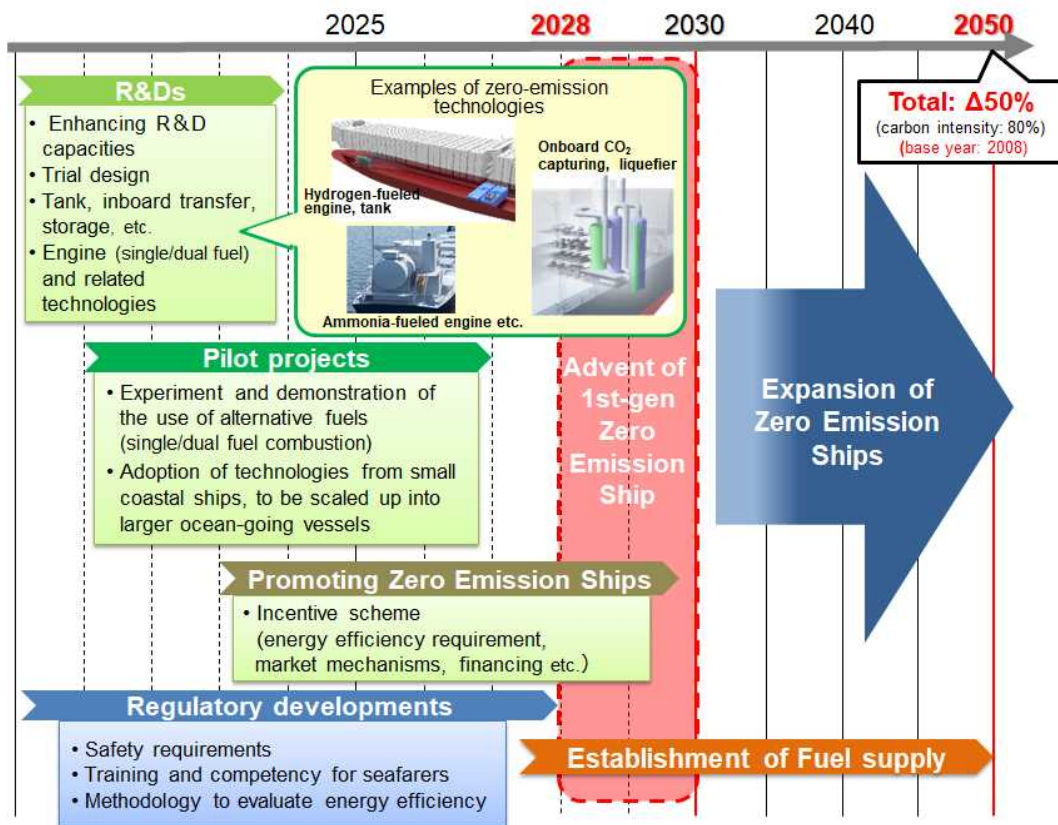

Figure 5.1-1: Roadmap Outline

## **Section 5.2: Research and Development**

The Project explored the possible research and development actions towards introduction of Zero Emission Ships, as shown in Figure 5.2-1.

### **5.2.1 Enhancing Research and Development capacities**

In order to efficiently carry out fruitful R&D programs, a joint R&D system would be effective. For example, setting up a joint venture for collaborative research projects would reduce duplicated costs and investment, while allowing synergy and economy of scale.

Another possible approach is to launch an international scheme to facilitate R&D activities. A large-scale R&D investment is necessary for introduction of zero emission ships, and it is desirable to establish an international framework for procuring financial resources for such investment. An establishment of a new framework for international R&D funds, in which each ship is obliged to make contribution to the fund proportional to the annual fuel consumption<sup>8</sup>, could be a possible way forward, if it was designed and implemented in a reasonable and effective manner. An example would be shipowners contributing an amount proportionate to their annual fuel consumption to set up a fund to finance internationally selected R&D projects. Contributions of around two dollars per ton of fuel oil consumption may raise R&D funds of around 500 million dollars per year.

### **5.2.2 Pilot Projects**

For introduction of hydrogen fuels and ammonia fuels, it would be essential to develop hydrogen-fueled engines and ammonia-fueled engines by 2024. Then, pilot projects for the dual-fuel combustion engines using conventional fuel and either of these alternative fuels should be conducted possibly using small coastal ships by 2026. Subsequently, the technologies would be sophisticated and scaled up to larger ocean-going ships to realize Zero Emission Ships by 2028.

To encourage the use of LNG fuels and carbon-recycled methane fuels, it is vital to swiftly establish measures to minimize methane slip.

For introduction of wind propulsion systems, a robust and reliable mechanism to verify the energy saving performance by means of wind power should be established.

Onboard CO<sub>2</sub> capturing system is based on technology that has already been practically implemented on land. For onboard applications, it is necessary to address improvement in CO<sub>2</sub> capturing rate, reduction of size, cost and necessary power, countermeasures against saltwater damage and vibration, and other issues related to operation and verification.

For super-efficient LNG-fueled ships, it would be necessary to resolve issues related to maneuverability in case where the ship is designed to have much lower speed and power than the conventional ships.

Battery propulsion have already reached the verification phase and been applied to small domestic ships.

---

<sup>8</sup> Proposed to the IMO as the International Maritime Research and Development Board (IMRB) by international shipping industries.



However, as discussed in Section 4.3, given the low energy density of existing batteries, it is difficult to apply them to large ocean-going ships.

It should be noted that uptake of the aforementioned technologies and alternative fuels will depend considerably on the progress of development of onshore infrastructure for supply, including bunkering facilities.

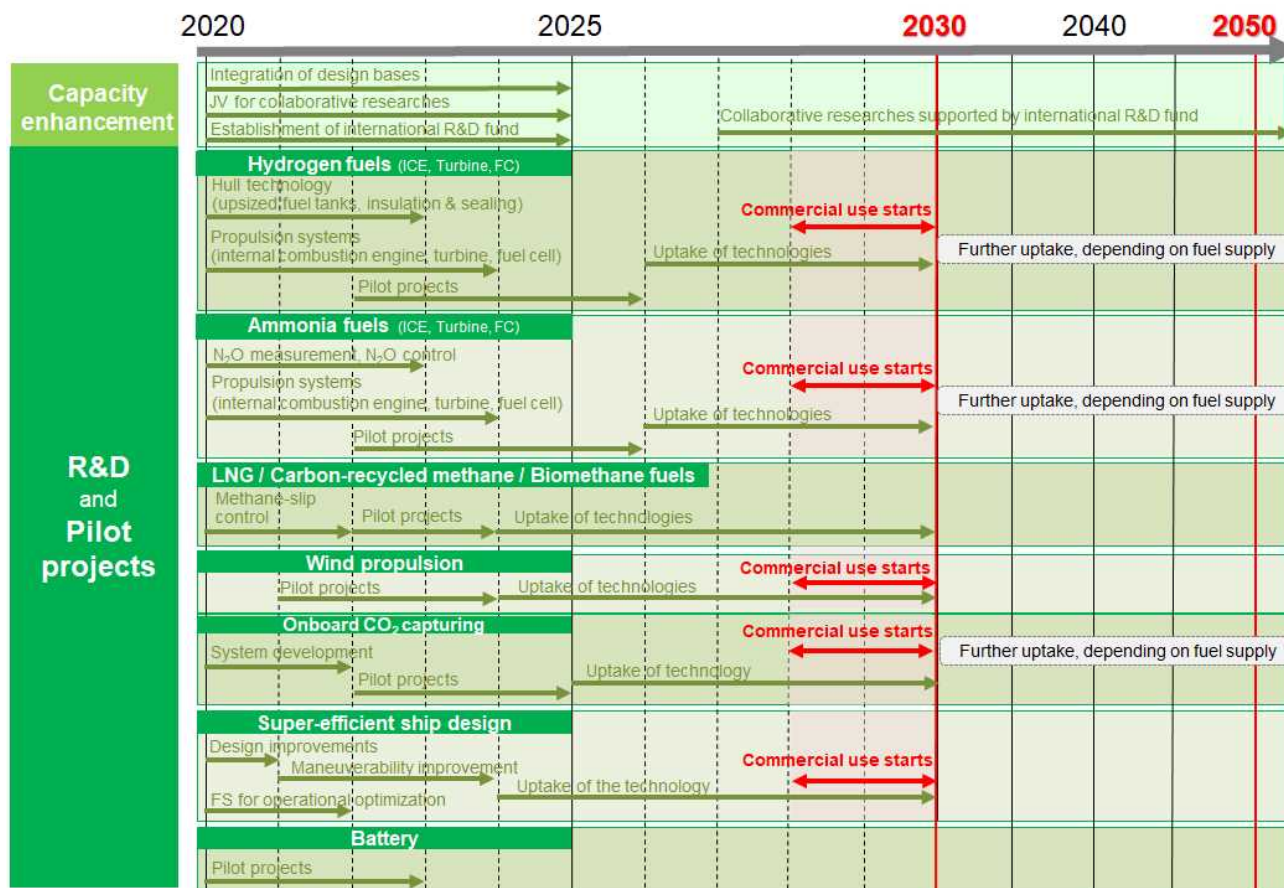

Figure 5.2-1: R & D and Pilot Project Roadmap

## Section 5.3: Regulatory Developments

Figure 5.3-1 lays out actions and measures for regulatory developments that are considered necessary for introduction of zero emission ships.

### 5.3.1 Short-, Mid- and Long-Term Measures

Deliberations on the short-term measures are under way at the IMO aiming at an agreement by 2023 as mentioned in Sections 2.1 and 3.2. Japan is proposing the energy efficiency existing ship index (EEXI) regulations aiming at approval as soon as possible. In addition to the EEXI, the mandatory rating mechanism as proposed by China to visualize actual energy efficiency would be another way to incentivize further operational improvement.

For mid- and long-term measures, the IMO is currently discussing the development of lifecycle

GHG/carbon intensity guidelines for fuels. It may also need to address issues on the use of carbon-recycled fuels and biofuels in the context of cross-border with other sectors. In the future, it may need to draw up market-based measures (MBMs), such as global levy, to create economic incentives for GHG reduction.

### **5.3.2 Revision to Existing MARPOL-Related Regulations**

The EEDI regulations under the MARPOL Convention provide for up to Phase 3 requirements, which were originally scheduled to come into effect in 2025, but decided to be brought forward to 2022 for some ship types. Currently, new Phase 4 requirements are also being discussed at the IMO, which may envision the introduction of alternative fuels and other measures. Although the year of application and the level of stringency of Phase 4 has not been decided yet, the following issues, inter alia, could be incorporated in the EEDI framework from Phase 4:

- A verification scheme for alternative fuels;
- EEDI calculation for electric propulsion ships; and
- Inclusion of wind propulsion systems into the EEDI.

### **5.3.3 Safety requirement**

To introduce alternative fuels, some of the existing rules on ship safety and seafarers must be reviewed and revised as appropriate.

For example, the IMO has already developed safety standards for LNG-fueled ships in the International Code of Safety for Ships using Gases or other Low-flashpoint Fuels (IGF Code).<sup>9</sup> However, there is no safety standards dedicated for ships using hydrogen or ammonia fuels. According to the International Code for the Construction and Equipment of Ships Carrying Liquefied Gases in Bulk (IGC Code), use of ammonia fuels is not allowed for liquid ammonium carriers at the moment.<sup>10</sup> Therefore, revision or establishment of IMO rules will be necessary for general use of hydrogen and ammonia fuels. Similarly, safety standards for the onboard installation of wind propulsion systems and onboard CO<sub>2</sub> capturing systems will have to be developed. Training and competency for seafarers involved in the operation of ships using hydrogen or ammonia fuel would also be necessary to be considered.

### **5.3.4 Others**

Depending on the trends in the technological development of alternative fuels and the state of the supply of these fuels, the revision of existing marine fuel standards, such as ISO 8217, or the formulation of new standards would be necessary.

---

<sup>9</sup> IMO, International Code of Safety for Ships Using Gases or Other Low-Flashpoint Fuels

<sup>10</sup> IMO, The International Code for the Construction and Equipment of Ships Carrying Liquefied Gases in Bulk

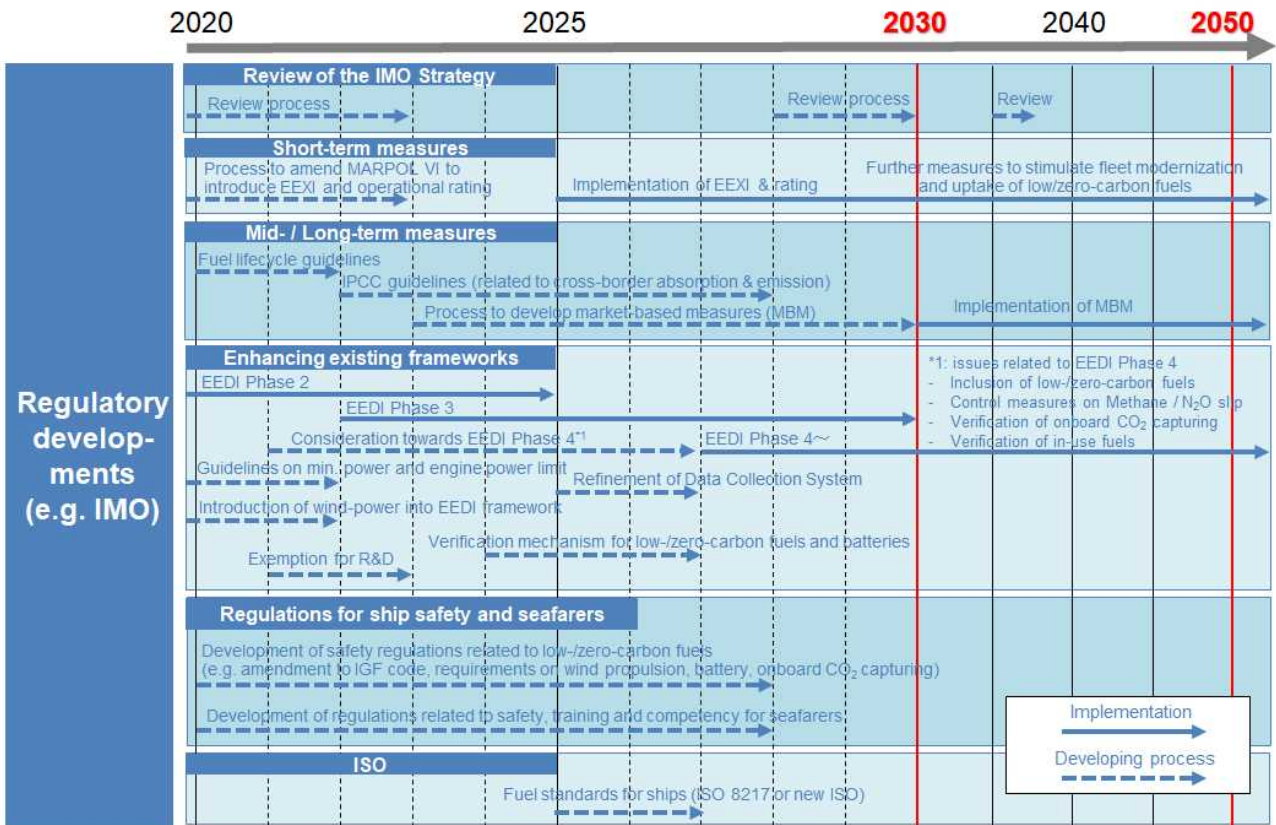

The table describes potential actions to be taken, but it does not prejudice any policies/regulations/funding to be decided in the future.

Figure 5.3-1: Regulatory Developments Roadmap



## **Chapter 6: Concluding remarks**

Potential of zero emission from international shipping in the future depends on intricately entangled and uncertain factors, such as technological developments, supply capacity and availability of alternative fuels, and their costs, which cannot be precisely predicted at this stage. Under these circumstances, based on information currently available, the Project analyzed and explored possible emission pathways that enable international shipping to meet the GHG reduction target set out in the IMO Strategy. It then developed detailed plan of actions, including technological developments and regulatory development that would be necessary to realize the pathways and presented them in the form of a Roadmap.

The Roadmap needs to be revised continuously through reviewing and narrowing down the optional pathways and actions taking into account updated circumstances and progresses. The actions, roles, systems and funding mechanisms for the implementation of the Roadmap needs to be materialized further by all stakeholders with a view to enhance commercial feasibility and realize the construction and operation of Zero Emission Ships as soon as possible.

# Appendices



# Appendix 1. Estimate of International Seaborne Trade

To predict the future CO<sub>2</sub> emissions (BAU emissions) from international shipping, international seaborne trade volume was estimated up to 2050. Details of the estimation are as follows.

## 1. Outline of the Method of Estimate on Seaborne Trade

The method for estimating the international seaborne trade is outlined in the Figure Appendix 1-1.

Based on the assumption that the international seaborne trade correlates with socio-economic indicators (GDP, population, and energy consumption), a regression model using such indicators was built for the trade volume for each commodity.

Next, by inputting the predicted values for the socio-economic indicators for a period up to 2050 into the regression formulas, the future trade volume (in tons) of each commodity was calculated. For this purpose, GDP forecast from OECD and projection on energy consumption and population from the International Institute for Applied Systems Analysis (IIASA) were used.

Further, the future seaborne trade of each commodity on the ton-mile basis was estimated by multiplying the estimated trade volume in tons by the average distance travelled for each commodity.

Finally, Seaborne trade on the ton-mile basis were estimated by ship type and size by setting a corresponding relationship between the trade volume of each commodity and the ship type and size of the ships that transport the commodity.

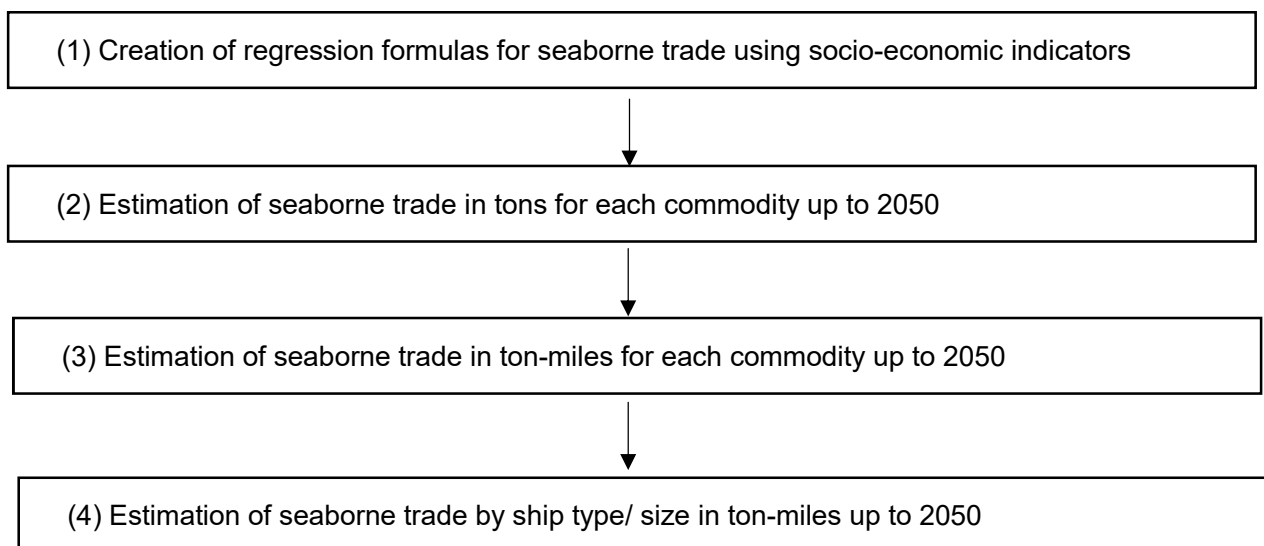

Figure Appendix 1-1: Outline of the Method for Estimation of Seaborne Trade

## 2. Regression Formulas for Seaborne Trade

### (1) Data used for creating the equations

The regression models were created by assuming that seaborne trade of each commodity (in tons) are correlated with socio-economic indicators. To verify this assumption, data from Clarksons<sup>11</sup> which classify commodities in detail, were used as the actual values for trade volume by commodity. Data from Clarksons is used widely in other studies, including in the past IMO study (3rd IMO GHG Study<sup>12</sup>) and in CE Delft's analyses of international seaborne trade.<sup>13</sup> The target commodities to be analyzed here were classified as follows in accordance with Clarksons' classifications.

- [Target commodities]Crude Oil
- Oil Products
- Coking Coal
- Steam Coal
- Iron Ore
- Bauxite/Alumina
- Grain, Minor Bulk
- Container
- Other Dry Cargo
- LPG, LNG, Chemical
- Car
- Reefer
- Cruise Passenger

Here, the unit for Cruise Passenger is the number of passengers while other commodities are measured in tons. In this study, by using both printed and online formats of Clarksons data, Bauxite/Alumina was considered separately from Minor Bulk, and likewise Reefer and Car were categorized differently from Other Dry Cargo.

Historical GDP values were taken from data published by OECD<sup>14</sup> and population data was taken from data published by the United Nations<sup>15</sup>. Energy consumption data was taken from data published by IEA<sup>16</sup>. As to GDP data, global total GDP(US Dollar, 2010) was used, with GDP values available since 1995. Data on the global total population from the United Nations was used, with data being available since 1950. The IEA energy consumption data includes the global total values for oil, coal, and gas

---

<sup>11</sup> Clarkson Research, Shipping Review & Outlook, Spring 2019, pp115, pp145.

<sup>12</sup> IMO, Third IMO Greenhouse Gas Study 2014, 2015.

<sup>13</sup> CE Delft, Update of maritime greenhouse gas emission projections, January 2019.

<sup>14</sup> OECD, Economic Outlook No. 103, July 2018, Long-term baseline projections, [https://stats.oecd.org/Index.aspx?DataSetCode=EO103\\_LTB#](https://stats.oecd.org/Index.aspx?DataSetCode=EO103_LTB#)

<sup>15</sup> United Nations, World Population Prospects 2019, <https://population.un.org/wpp/>

<sup>16</sup> IEA, Data and statistics, <https://www.iea.org/data-and-statistics>

(primary energy supply, unit: joule), and values for global total energy consumption dating since 1990.

## (2) Regression formulas

In creating the regression formulas, relationships between variables were considered using the three types of formulas — linear, linear (logarithm), and sigmoid formulas (logistic curve) — shown (1) to (3) below, with trade volume being the explained variable and a socio-economic indicator being the explanatory variable.

Linear	$Y = a X + b$	... Formula (1)
--------	---------------	-----------------

Linear (Logarithm)	$LN(Y) = a LN(X) + b$	... Formula (2)
--------------------	-----------------------	-----------------

Sigmoid	$Y = \frac{c}{1 + a \exp(-bX)}$	... Formula (3)
---------	---------------------------------	-----------------

Here, Y is the explained variable, X is the explanatory variable, and a, b, and c are parameters.

In the linear regression formula, a linear relationship, in which the explained variable Y changes in proportion to changes in the explanatory variable X, was assumed. In the linear (logarithm) regression formula, it was assumed that the elasticity of between X and Y is constant. In addition, the application of the sigmoid (logistic curve) was considered for some commodities expected to see restricted demand in the future. This curve is often applied to express a phenomenon concerning the trend toward an increase in the target commodity, in which the increase is accelerated at the onset and saturated in the end. It therefore enables the expression of the effects of restriction. In the logistic curve, the parameter c indicates the upper limit of the explained variable in the regression formula.

Socio-economic indicators that are considered to be strongly related to each commodity were used as the explanatory variables in the regression formulas. Oil consumption was adopted as the explanatory variable for Crude Oil, Oil Products, LPG, and Chemicals. Coal consumption was adopted for Steam Coal while gas consumption was used for LNG, and population was adopted for Grain. For the other commodities, GDP was used as the explanatory variable.

Parameters for the regression formulas were determined through regression analyses using historical values for the period from 1995 to 2018 in the case of GDP, values from 1985 to 2017 in the case of population, and values from 1990 to 2017 in the case of energy consumption. The type of regression formulas was determined by comparing the R<sup>2</sup> (coefficient of determination) values (the closer to 1 it is, the better the correlation is), which indicate the levels of adaptation between variables. However, the logistic curve parameter c needs to be determined in advance. Therefore, value for the parameter c was set to one at which the R<sup>2</sup> value became appropriate.

Table Appendix 1-1 shows the explanatory variable, the regression formula, and the R<sup>2</sup> value of each commodity.

Table Appendix 1-1: Results of Regression Formula Consideration

No.	Commodity	Explanatory variable: Unit	Unit of explained variable	Regression formula		R <sup>2</sup>
1	Iron Ore	GDP: Billion USD	Million tons	Sigmoid	$Y=1614/(1 + 97.723 \exp (-7.122E - 05 X))$	0.98
2	Coking Coal	GDP: Billion USD	Million tons	Sigmoid	$Y = 362/(1 + 4.152 \exp (-2.501E - 05 X))$	0.94
3	Steam Coal	Coal consumption: EJ	Million tons	Linear	$Y = 8.960X - 584.922$	0.95
4	Bauxite/Alumina	GDP: Billion USD	Million tons	Sigmoid	$Y = 206/(1 + 18.596 \exp (-3.778E - 05 X))$	0.96
5	Grain	Population: Million people	Million tons	Sigmoid	$Y = 722/(1 + 8733.995 \exp (-1.275E - 03 X))$	0.98
6	Minor Bulk	GDP: Billion USD	Million tons	Sigmoid	$Y = 2238/(1 + 8.185 \exp (-4.002E - 05 X))$	0.99
7	Container	GDP: Billion USD	Million tons	Linear	$Y = 0.029X - 869.709$	0.99
8	Other Dry cargo	GDP: Billion USD	Million tons	Sigmoid	$Y = 710/(1 + 18.900 \exp (-5.127E - 05 X))$	0.98
9	Crude Oil	Oil consumption: EJ	Million tons	Linear	$Y = 14.161X - 586.546$	0.89
10	Oil Products	Oil consumption: EJ	Million tons	Linear	$Y = 13.563X - 1500.875$	0.95
11	LPG	Oil consumption: EJ	Million tons	Linear (Logarithm)	$Y = \exp (-8.710 + 2.489 \text{LN}(X))$	0.88
12	LNG	Gas consumption: EJ	Million tons	Linear (Logarithm)	$Y = \exp (-7.300 + 2.670 \text{LN}(X))$	0.99
13	Chemicals	Oil consumption: EJ	Million tons	Linear	$Y = 3.661X - 399.872$	0.94
14	Car	GDP: Billion USD	Million tons	Sigmoid	$Y = 44/(1 + 10.209 \exp (-3.561E - 05 X))$	0.90
15	Reefer	GDP: Billion USD	Million tons	Sigmoid	$Y = 345/(1 + 7.639 \exp (-3.190E - 05 X))$	0.99
16	Cruise Passenger	GDP: Billion USD	Million passengers	Linear	$Y = 3.864E - 04X - 9.327$	0.99

GDP: 2010 value based on prices, EJ: Exajoule

Figure Appendix 1-2 shows actual seaborne trade by commodity and estimate which was obtained by applying the regression formulas. However, the regression formulas for Grain and Other Dry Cargo were created based only on recent years' trends.

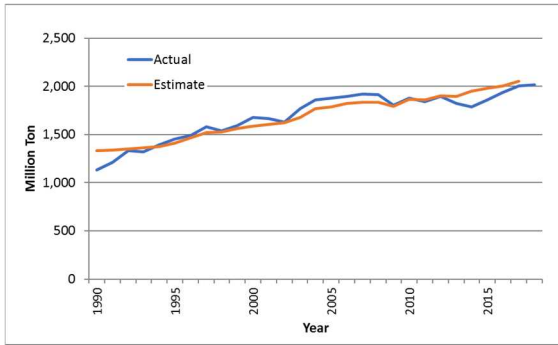

Crude Oil

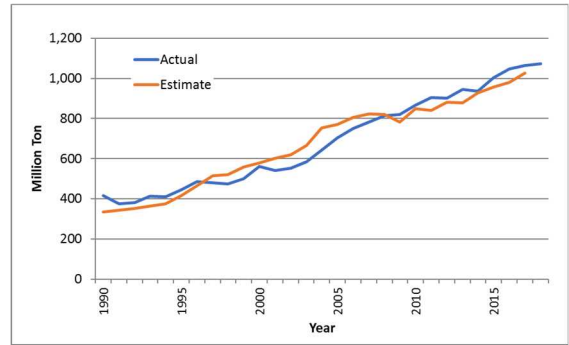

Oil Products

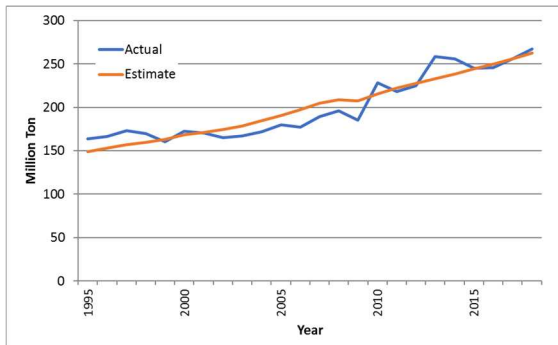

Coking Coal

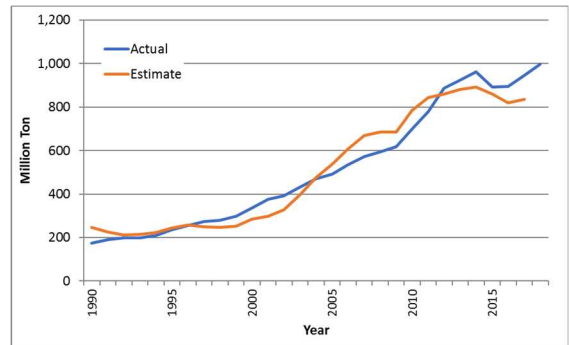

Steam Coal

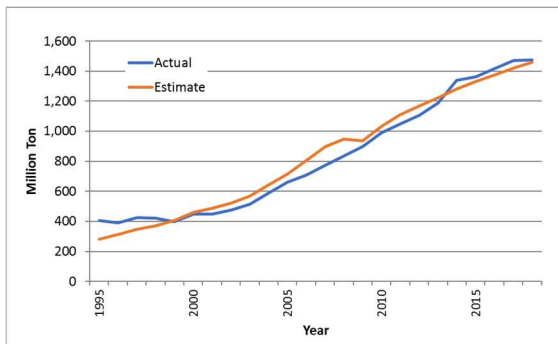

Iron Ore

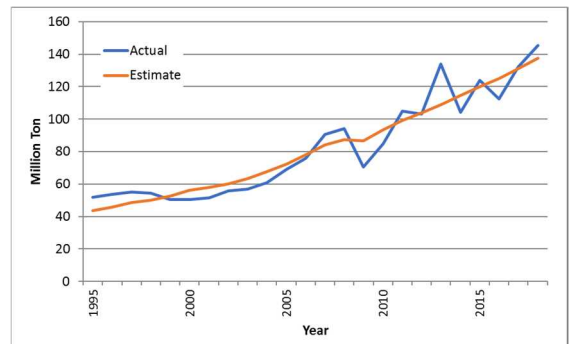

Bauxite/Alumina

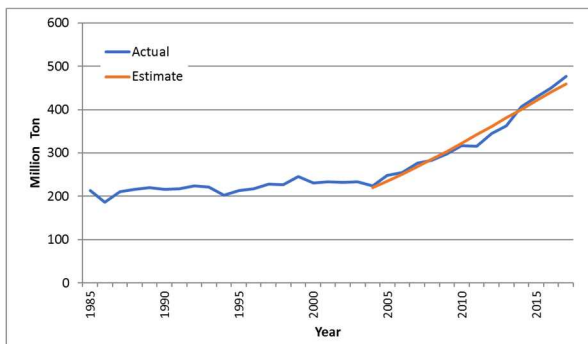

Grain

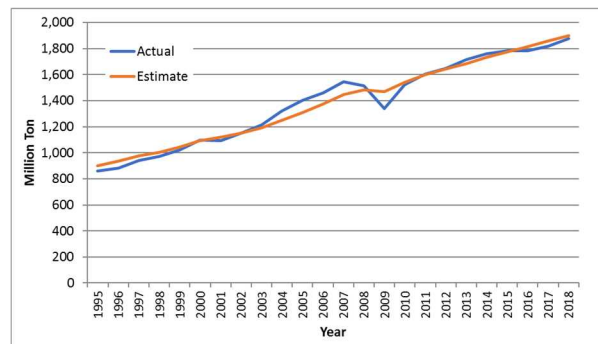

Minor Bulk

Figure Appendix 1-2: Comparison of Actual and Estimated Values of Seaborne Trade by Commodity (Blue: Actual value, Orange: Estimate)

\*This figure continues to next page.



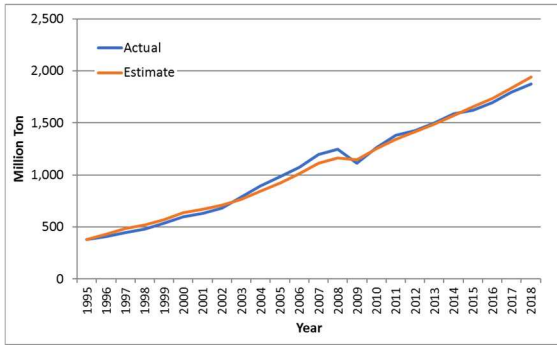

Container

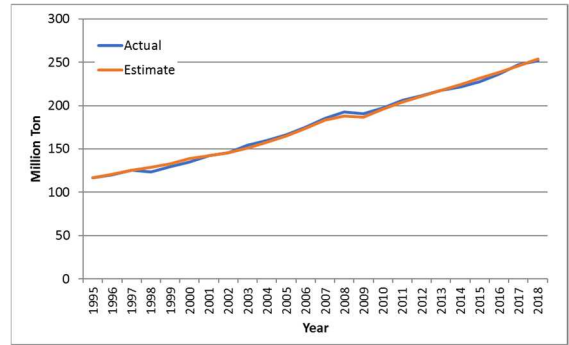

Reefer

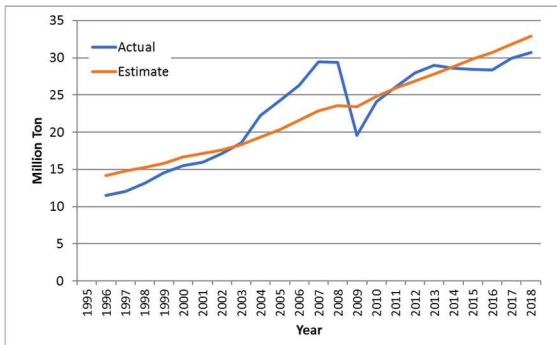

Car

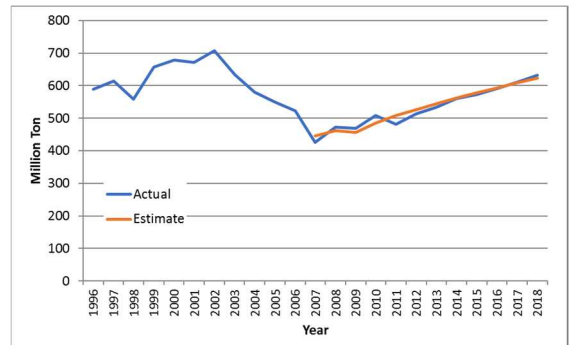

Other Dry Cargo

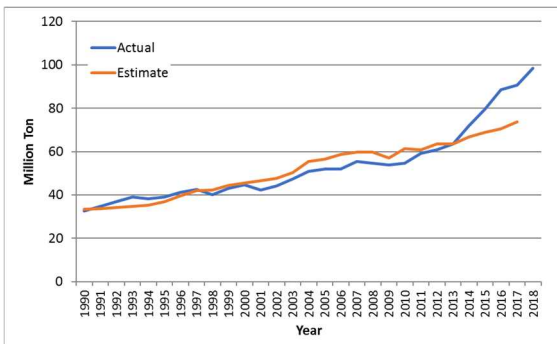

LPG

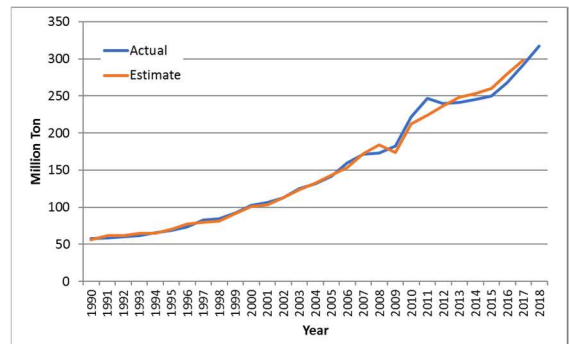

LNG

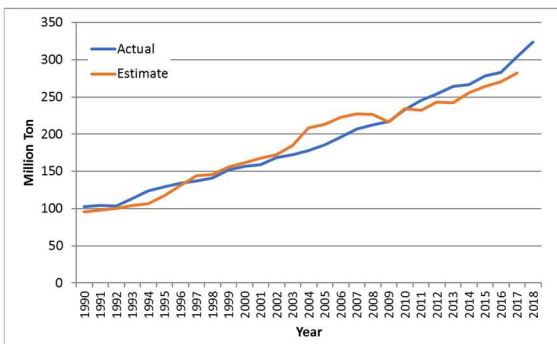

Chemical

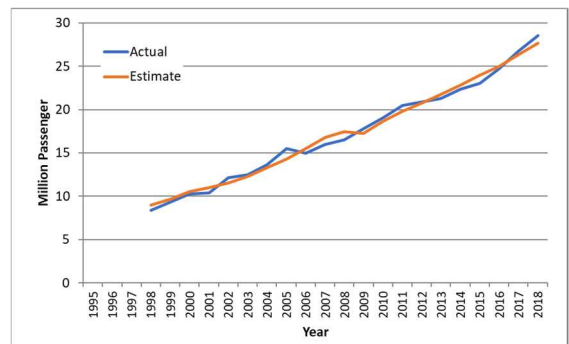

Cruise Passenger

Figure Appendix 1-2: Comparison of Actual and Estimated Values of Seaborne Trade by Commodity (Blue: Actual value, Orange: Estimate) (Continued)

### 3. Estimate of Seaborne Trade in Tons for Each Commodity

Trade volume in tons up to 2050 was estimated by inputting the projections of socio-economic indicators into the regression formulas. The socio-economic data used are as follows.

OECD forecasts were used for the prediction of the future GDP. This prediction is relatively close to the SSP 3 scenario, which shows modest growth, among the multiple GDP forecasts adopted by the Intergovernmental Panel on Climate Change (IPCC) that were also used for the 3rd IMO GHG Study.

Data from the IIASA<sup>17</sup> was used for population and energy consumption. This database contains calculated energy consumptions based on the Representative Concentration Pathways (RCP) and Shared Socioeconomic Pathways (SSP) adopted by the IPCC. From the database, this study used energy consumption forecasts calculated with the Asia-Pacific Integrated Model/Computable General Equilibrium (AIM/CGE) model from the National Institute for Environmental Studies of Japan (NIES) based on the RCP scenarios and SSP scenarios. The SSP scenario shows socio-economic indicators, such as GDP and population, while the RCP scenario is a representative GHG concentration scenario that is used by the IPCC's climate model. The numerical value shown at the end of each scenario of RCP is a physical indicator called the radiative forcing value (unit: W/m<sup>2</sup>). The greater the value is, the higher its effect on the warming of the earth's surface is. This study used forecasts for energy consumption and population in 2030, 2040, and 2050 from the three scenarios shown in Table Appendix 1-2, including the RCP 1.9 shown by IPCC in 2018. Socio-economic conditions were analyzed using the SSP1 scenario with replacing the GDP forecasts from SSP 1 with the OECD forecasts (hereinafter referred to as OECD, SSP 1).

Figure Appendix 1-3 shows actual GDP, population, and energy consumption and the forecasts for these indicators up to 2050, which were used in this study.

Table Appendix 1-2: Representative Concentration Pathways (RCP) Used in this Study

RCP 4.5 (Middle-level stabilization scenario)	Radiative forcing level will be stabilized at 4.5 W/m <sup>2</sup> by the end of this century. It is likely that the future temperature rise will be suppressed to 2.5 °C or less.
RCP 2.6 (Low-level stabilization scenario)	Radiative forcing level will hit its peak and then lower to 2.6 W/m <sup>2</sup> around the end of this century. It is likely that the future temperature rise will be suppressed to 1.6 °C or less.
RCP 1.9	Radiative forcing level will be stabilized at 1.9 W/m <sup>2</sup> by the end of this century. It is likely that the temperature rise at the peak time will be suppressed to 1.5 °C or less. (This scenario is used in the IPCC's special report on the impact of a global warming of 1.5 °C (2018).)

<sup>17</sup> IIASA, SSP Database (Shared Socioeconomic Pathways) - Version 2.0, December 2018, <https://tntcat.iiasa.ac.at/SspDb>

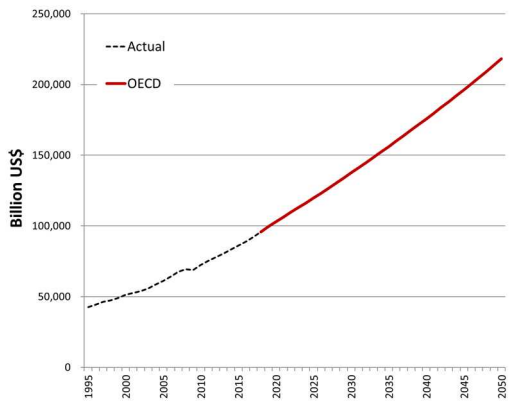

GDP

(Actual: 1995 to 2018, Estimated: 2019 and after)

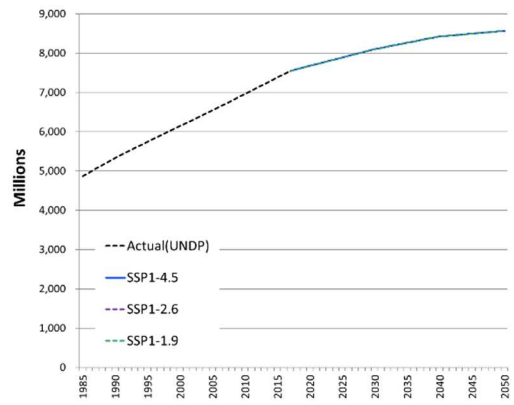

Population

(Actual: 1985 to 2017, Estimated: 2018 and after)

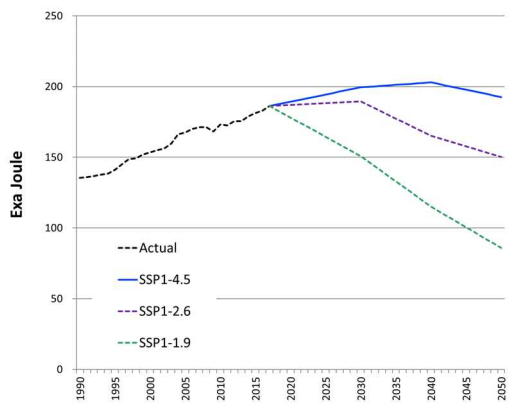

Oil consumption

(Actual: 1990 to 2017, Estimated: 2018 and after)

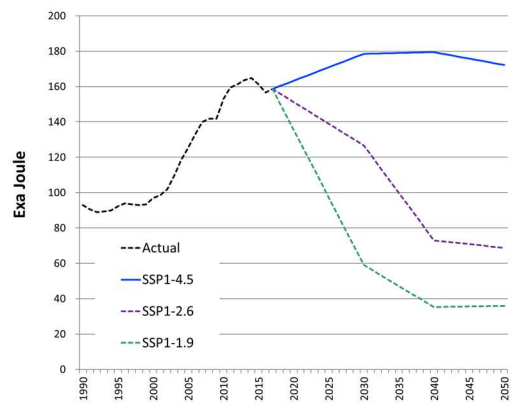

Coal consumption

(Actual: 1990 to 2017, Estimated: 2018 and after)

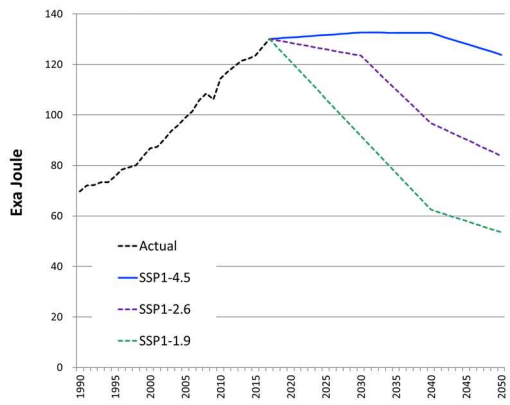

Gas consumption

(Actual: 1990 to 2017, Estimated: 2018 and after)

Figure Appendix 1-3: GDP, Population, and Energy Consumption Forecasts up to 2050

Future trade volume (in tons) was estimated by inputting the predicted values of the explanatory variables from GDP provided by OECD and others from SSP/RCP scenarios into the above-mentioned regression formulas.

In this process, the Oil Products estimates calculated by the regression formula were corrected on the assumption that the ratio of the trade volume of Oil Products to Crude Oil is constant. In the Clarksons data, the ratio of the trade volume of Oil Products to Crude Oil from 2014 to 2018 was 0.533 on average. Accordingly, the estimate was made assuming the above ratio will remain unchanged in the future.

Table Appendix 1-3 shows estimates of total seaborne trade up to 2050, expressed in a factor of that in 2008 (8.627 billion tons). Estimates of seaborne trade by commodity are shown in Figure Appendix 1-4.

Appendix 1-3: Estimate of Trade Volume in Tons up to 2050

(Total volume of all commodities, excluding the passengers, index: trade volume in 2008 = 1)

Scenario	2020	2030	2040	2050
OECD, SSP1/RCP 4.5	1.44	1.65	1.82	1.91
OECD, SSP1/RCP 2.6	1.42	1.56	1.57	1.66
OECD, SSP1/RCP 1.9	1.39	1.36	1.40	1.47

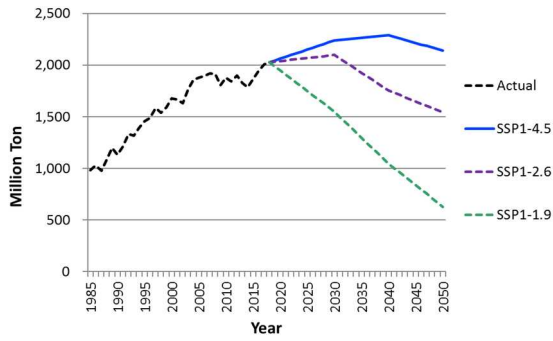

Crude Oil

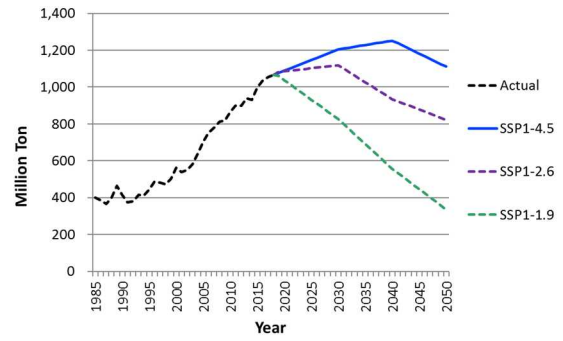

Oil Products

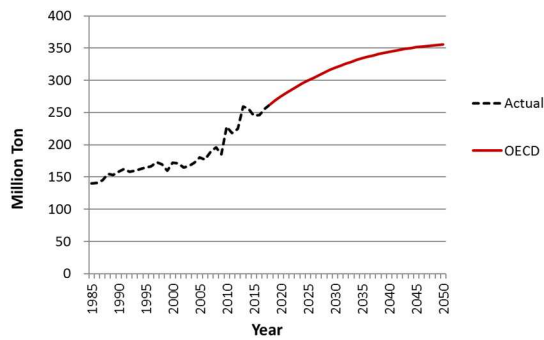

Coking Coal

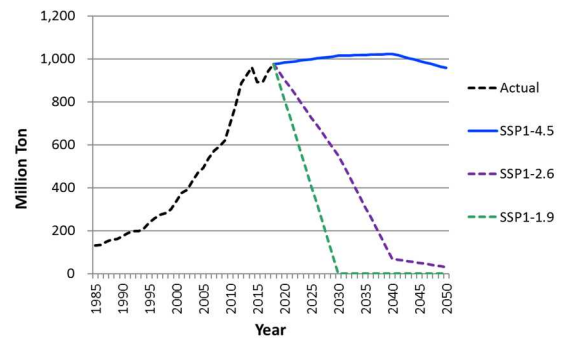

Steam Coal

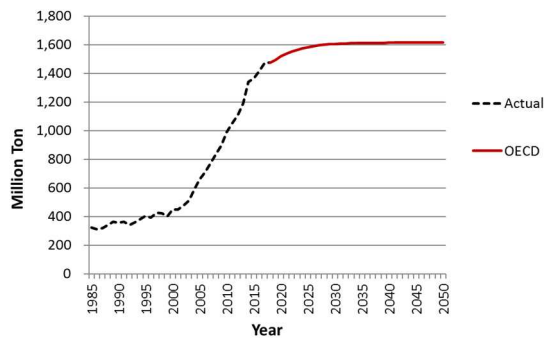

Iron Ore

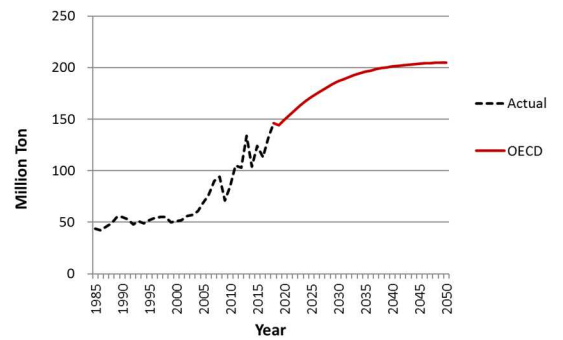

Bauxite/Alumina

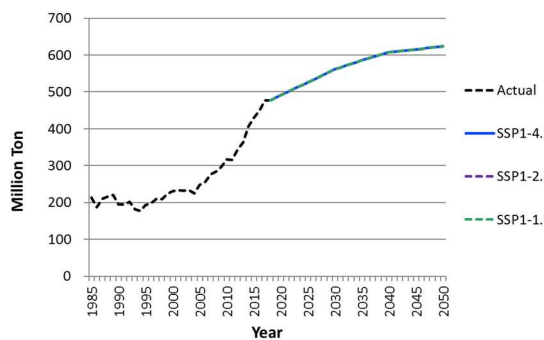

Grain

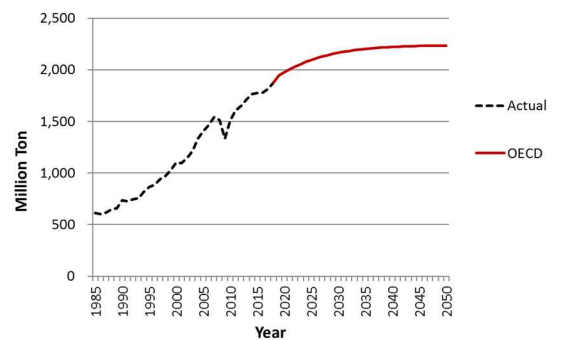

Minor Bulk

Figure: Appendix 1-4: Estimate of Seaborne Trade in Tons by Commodity up to 2050

\*This figure continues to next page.

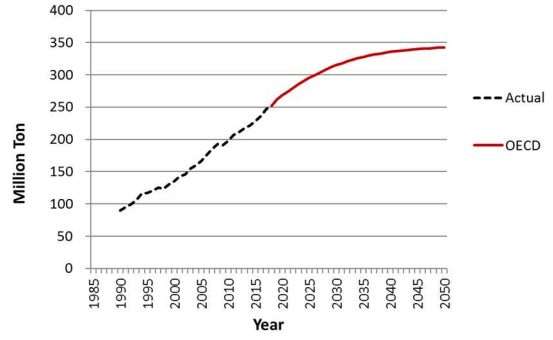
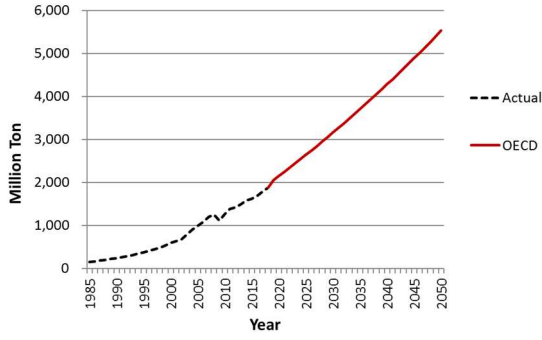

**Container**

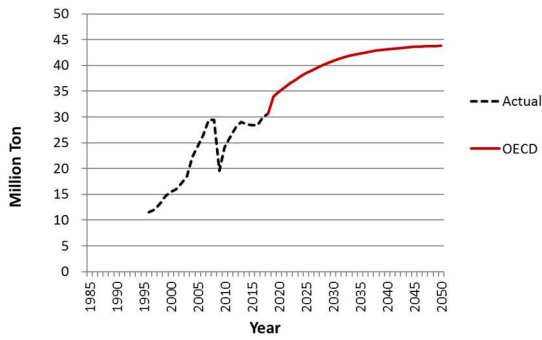

**Reefer**

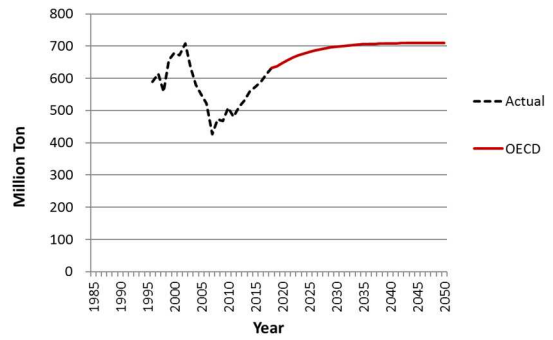

**Car**

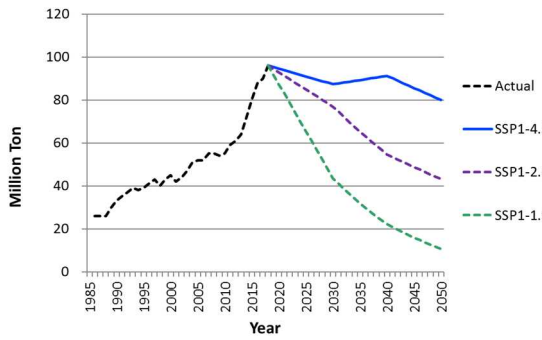

**Other Dry Cargo**

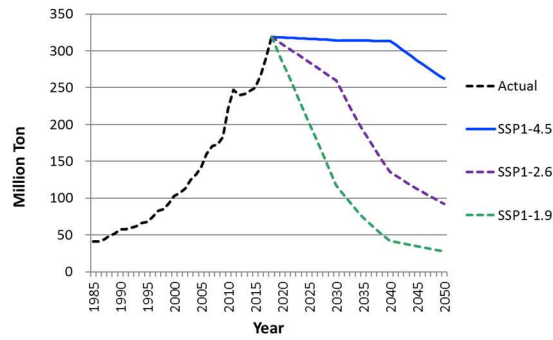

**LPG**

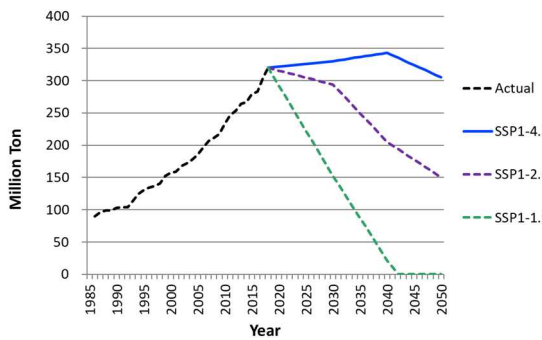

**LNG**

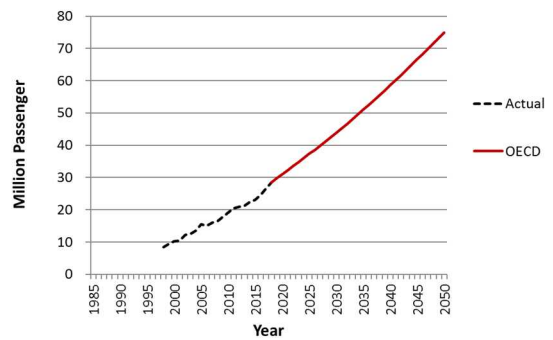

**Chemical**

**Cruise Passenger**

Appendix 1-4: Estimate of Seaborne Trade in Tons by Commodity up to 2050 (continued)

## 4. Estimate of Seaborne Trade in Ton-miles for Each Commodity

Seaborne trade in ton-miles was estimated by multiplying the trade volume in tons by the average length of haul in nautical miles. The average length of haul was calculated based on seaborne trade in ton-miles and in tons, both published by Clarksons.<sup>18</sup> Concerning Coal, the total of Coking Coal and Steam Coal was used because these commodities are not distinguished from each other in the ton-mile data from Clarksons. In addition, regarding Reefer and Cruise Passenger, no published data in ton-miles exists. Therefore, for these categories, a method to estimate trade volume without referring to distance travelled was created. Although the Clarkson does not provide values in ton-miles for Car, the number of vehicles transported between major countries in 2017 is published in another data source<sup>19</sup>. Therefore, these values were used to estimate trade volume in ton-miles for Car. Specifically, the number of vehicles was multiplied by the distance between the major countries, and the product was divided by the total number of vehicles (for 2017, 9.32 million), resulting in the average distance travelled.

## 5. Estimate of Seaborne Trade by Ship Type and Size in Ton-miles

Trade volume by ship type and size was estimated by setting correspondence relationships between trade volume (ton-miles) of each commodity and the type and size of ship transporting it. Ship type and size was classified in accordance with the 3rd IMO GHG Study. The relationships between ship types and commodities are shown in Appendix 1-4.

Table Appendix 1-4: Relationships between Ship Types and Commodities

No.	Ship types in the 3rd GHG Study	Target commodities
1	Bulk Carrier	Coking Coal, Steam Coal, Iron Ore, Bauxite/Alumina, Grain, Minor Bulk
2	Chemical Tanker	Chemical
3	Container	Container
4	General Cargo	Part of Other Dry Cargo
5	Liquefied Gas Tanker	LPG, LNG
6	Oil Tanker	Crude Oil, Oil Products
7	Other Liquids Tankers	None
8	Ferry-pax Only	None
9	Cruise	Cruise Passenger
10	Ferry- RoPax	Part of Other Dry Cargo
11	Refrigerated	Reefer
12	Ro-Ro	Part of Other Dry Cargo
13	Ro-Ro Vehicle	Car

<sup>18</sup> Clarkson Research, Shipping Review & Outlook, Spring 2019, pp115, pp145.

<sup>19</sup> Clarkson Research, Car Carrier Trade and Transport 2018.

By following the relationships between ship types and commodities, trade volume for each ship type and size was estimated for each category, (1), (2) or (3) below. For the estimation, data from the 3rd IMO GHG Study on tonnage (DWT) and distance traveled (nautical miles) by ship type and size from 2008 until 2012 was used. Distance traveled was calculated from the number of days at sea and the average vessel speed. In this report, it was assumed that multiple of tonnage (DWT) of each ship type and size by distance traveled (miles) indicates the volume of activity of each ship type and size and that the amount of trade volume for each category was determined based on the ratio of this value to the whole (ratio of DWT-mile value of each ship type and size).

(1) One-to-one relationship between ship type and commodity (Chemical Tanker, Container, Cruise, Reefer, Car)

For Chemical, Container, and Car, for which actual or estimated values for seaborne trade in ton-miles from Clarkson exist, the ton-mile value for each commodity was attributed to ship size based on the ratio of DWT-mile value of each ship type and size. Regarding Cruise and Reefer, for which ton-mile values do not exist, the ton value for each commodity was attributed to ship size based on the ratio of DWT-mile value of each ship type and size to the whole.

(2) One-to-many relationship between ship type and commodity (Bulk Carrier, Oil Tanker)

For Bulk Carrier, the percentage of each ship size (Supra/Handysize, Panamax, Capesize)<sup>20</sup> in ton-mile values for each commodity, published by IHS Markit Ltd.,<sup>21</sup> were applied to set the ton-mile ratio for each. Ton-miles for each commodity were attributed to ship size by multiplying this by the percentage of DWT-miles of each ship type and size, so that the data would correspond to the ship type and size classification of this study.

For Oil Tanker, ton-miles for Crude Oil was attributed to ship size based on the percentage of DWT-miles of each ship type and size. Ton-miles for Oil Products were attributed to ship size based on the DWT-miles percentage of ship types and size excluding 120,000 DWT or larger Oil Tankers.

(3) Many-to-one relationships between ship type and commodity (General Cargo, Ferry- RoPax, Ro-Ro)  
Ton-miles for Other Dry Cargo was distributed among General Cargo, Ferry- RoPax, and Ro-Ro based on the percentage of DWT-miles of each ship type and size.

In this section, trade volume in ton-miles by ship type and size up to 2050 were estimated using the percentage of DWT-miles of each ship type and size for 2008. However, the estimations do not include values for Other Liquid Tanker and Ferry Pax Only, for which target commodities are not set, and Cruise

---

<sup>20</sup> Supra/Handysize: At around 18,000 DWT to 45,000 DWT, these ships can navigate almost anywhere in the world. Panamax: Approx. 60,000 DWT to 68,000 DWT, these ships are the largest that can pass through the Panama Canal. Capesize: Large ships around 150,000 DWT that cannot pass through the Panama or Suez Canals

<sup>21</sup> IHS Markit, Bulk Shipping Market Outlook, 2018 Maritime Silk Road Port International Cooperation Forum, <http://www.mpforum.org/>



and Refrigerated, for which ton-miles are not set. Figures Appendix 1-5, Appendix 1-6, and Appendix 1-7 show estimated ton-mile values for each scenario. Estimates by ship type and size are shown in Tables Appendix 1-5, Appendix 1-6, and Appendix 1-7. For OECD, SSP 1/ RCP 4.5, the total trade volume for all ship types is estimated to increase approx. twofold by 2050, when compared to 2008 (approx. 41 trillion ton-miles).

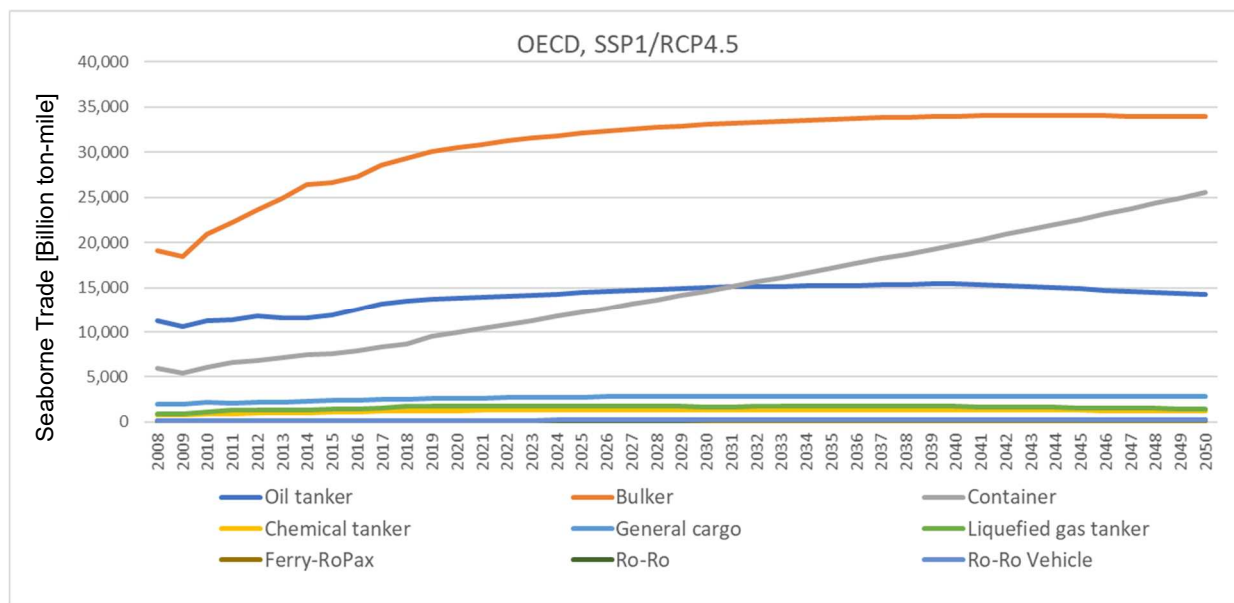

Appendix 1-5: Estimated Seaborne Trade in Ton-miles by Ship Type up to 2050 (OECD, SSP 1/RCP 4.5 scenario)



Appendix 1-5: Estimated Seaborne Trade in Ton-miles by Ship Type and Size

(Scenario: OECD, SSP 1/RCP 4.5)

Ship type	Ship size	2008	2020	2030	2040	2050
Oil Tanker	-4,999 dwt	127	161	176	181	166
	5 k-9,999 dwt	72	91	99	102	93
	10 k-19,999 dwt	76	96	105	108	99
	20 k-59,999 dwt	1,082	1,368	1,497	1,542	1,409
	60 k-79,999 dwt	940	1,188	1,300	1,339	1,224
	80 k-119,999 dwt	3,219	4,070	4,453	4,588	4,191
	120 k-199,999 dwt	1,391	1,664	1,805	1,845	1,727
	200 k+ dwt	4,312	5,157	5,596	5,720	5,353
Bulkier	-9,999 dwt	131	198	218	225	226
	10 k-34,999 dwt	3,516	5,309	5,825	6,008	6,038
	35 k-59,999 dwt	6,402	9,667	10,607	10,940	10,994
	60 k-99,999 dwt	4,150	6,935	7,543	7,863	7,805
	100 k-199,999 dwt	3,893	6,681	7,078	7,148	7,108
	200 k+ dwt	985	1,690	1,791	1,808	1,798
Container	-999 teu	228	379	556	754	973
	1 k-1,999 teu	659	1,095	1,609	2,180	2,813
	2 k-2,999 teu	724	1,203	1,767	2,395	3,090
	3 k-4,999 teu	1,781	2,958	4,346	5,890	7,599
	5 k-7,999 teu	1,644	2,731	4,012	5,438	7,016
	8 k-11,999 teu	892	1,481	2,176	2,949	3,805
	12 k-14,499 teu	54	90	133	180	232
	Chemical Tanker	-4,999 dwt	21	32	33	34
5 k-9,999 dwt		57	89	92	95	85
10 k-19,999 dwt		139	216	222	230	205
20 k+ dwt		605	942	967	1,005	893
General Cargo	-4,999 dwt	324	428	461	468	469
	5 k-9,999 dwt	497	656	707	717	719
	10 k+ dwt	1,174	1,549	1,671	1,694	1,698
Liquefied Gas Tanker	-49,999 cbm	93	182	177	178	151
	50 k-199,999 cbm	706	1,376	1,340	1,349	1,140
	200 k+ cbm	102	199	194	195	165
Ferry-RoPax	-1,999 grt	21	28	30	31	31
	2 k+ grt	106	139	150	152	153
Ro-Ro	-4,999 dwt	44	58	62	63	63
	5 k+ dwt	101	133	143	145	145
Ro-Ro Vehicle	-3,999 vehicle	35	42	49	52	53
	4 k+ vehicle	125	148	173	183	186

Unit: Billion ton-miles

Table Appendix 1-6: Estimated Seaborne Trade in Ton-miles by Ship Type and Size  
(Scenario: OECD, SSP1/RCP 2.6)

Ship type	Ship size	2008	2020	2030	2040	2050
Oil Tanker	-4,999 dwt	127	160	164	137	121
	5 k-9,999 dwt	72	90	92	77	68
	10 k-19,999 dwt	76	95	98	82	72
	20 k-59,999 dwt	1,082	1,358	1,397	1,168	1,027
	60 k-79,999 dwt	940	1,179	1,213	1,014	892
	80 k-119,999 dwt	3,219	4,040	4,156	3,474	3,054
	120 k-199,999 dwt	1,391	1,645	1,692	1,414	1,243
	200 k+ dwt	4,312	5,098	5,244	4,384	3,854
Bulkler	-9,999 dwt	131	198	213	214	216
	10 k-34,999 dwt	3,516	5,286	5,689	5,728	5,765
	35 k-59,999 dwt	6,402	9,625	10,359	10,430	10,498
	60 k-99,999 dwt	4,150	6,739	6,369	5,453	5,463
	100 k-199,999 dwt	3,893	6,616	6,688	6,347	6,330
	200 k+ dwt	985	1,674	1,692	1,606	1,601
Container	-999 teu	228	379	556	754	973
	1 k-1,999 teu	659	1,095	1,609	2,180	2,813
	2 k-2,999 teu	724	1,203	1,767	2,395	3,090
	3 k-4,999 teu	1,781	2,958	4,346	5,890	7,599
	5 k-7,999 teu	1,644	2,731	4,012	5,438	7,016
	8 k-11,999 teu	892	1,481	2,176	2,949	3,805
	12 k-14,499 teu	54	90	133	180	232
	Chemical Tanker	-4,999 dwt	21	31	29	20
5 k-9,999 dwt		57	88	82	57	42
10 k-19,999 dwt		139	212	197	138	101
20 k+ dwt		605	924	861	600	440
General Cargo	-4,999 dwt	324	428	461	468	469
	5 k-9,999 dwt	497	656	707	717	719
	10 k+ dwt	1,174	1,549	1,671	1,694	1,698
Liquefied Gas Tanker	-49,999 cbm	93	177	148	84	60
	50 k-199,999 cbm	706	1,340	1,123	634	451
	200 k+ cbm	102	194	163	92	65
Ferry-RoPax	-1,999 grt	21	28	30	31	31
	2 k+ grt	106	139	150	152	153
Ro-Ro	-4,999 dwt	44	58	62	63	63
	5 k+ dwt	101	133	143	145	145
Ro-Ro Vehicle	-3,999 vehicle	35	42	49	52	53
	4 k+ vehicle	125	148	173	183	186

Unit: Billion ton-miles

Table Appendix 1-7: Estimated Seaborne Trade in Ton-miles by Ship Type and Size

(Scenario: OECD, SSP 1/RCP 1.9)

Ship type	Ship size	2008	2020	2030	2040	2050
Oil Tanker	-4,999 dwt	127	153	121	82	49
	5 k-9,999 dwt	72	86	68	46	28
	10 k-19,999 dwt	76	91	72	49	29
	20 k-59,999 dwt	1,082	1,297	1,032	695	419
	60 k-79,999 dwt	940	1,126	896	604	364
	80 k-119,999 dwt	3,219	3,859	3,069	2,068	1,247
	120 k-199,999 dwt	1,391	1,571	1,250	842	508
	200 k+ dwt	4,312	4,869	3,874	2,609	1,574
Bulkier	-9,999 dwt	131	197	207	213	215
	10 k-34,999 dwt	3,516	5,259	5,527	5,707	5,756
	35 k-59,999 dwt	6,402	9,576	10,064	10,393	10,482
	60 k-99,999 dwt	4,150	6,507	4,980	5,279	5,385
	100 k-199,999 dwt	3,893	6,539	6,227	6,289	6,304
	200 k+ dwt	985	1,654	1,575	1,591	1,595
Container	-999 teu	228	379	556	754	973
	1 k-1,999 teu	659	1,095	1,609	2,180	2,813
	2 k-2,999 teu	724	1,203	1,767	2,395	3,090
	3 k-4,999 teu	1,781	2,958	4,346	5,890	7,599
	5 k-7,999 teu	1,644	2,731	4,012	5,438	7,016
	8 k-11,999 teu	892	1,481	2,176	2,949	3,805
	12 k-14,499 teu	54	90	133	180	232
	Chemical Tanker	-4,999 dwt	21	29	15	2
5 k-9,999 dwt		57	81	42	6	0
10 k-19,999 dwt		139	196	102	14	0
20 k+ dwt		605	855	446	63	0
General Cargo	-4,999 dwt	324	428	461	468	469
	5 k-9,999 dwt	497	656	707	717	719
	10 k+ dwt	1,174	1,549	1,671	1,694	1,698
Liquefied Gas Tanker	-49,999 cbm	93	164	71	28	17
	50 k-199,999 cbm	706	1,243	537	215	129
	200 k+ cbm	102	180	78	31	19
Ferry-RoPax	-1,999 grt	21	28	30	31	31
	2 k+ grt	106	139	150	152	153
Ro-Ro	-4,999 dwt	44	58	62	63	63
	5 k+ dwt	101	133	143	145	145
Ro-Ro Vehicle	-3,999 vehicle	35	42	49	52	53
	4 k+ vehicle	125	148	173	183	186

Unit: Billion ton-miles

## Appendix 2. Feasibility of Alternative Fuels and GHG Reduction Technologies

### 1. Feasibility of alternative fuels

Alternative fuels which could be used to achieve the 2050 target include hydrogen, ammonia, LNG, synthetic carbon-recycled fuels, and biofuels.

Table Appendix 2-1 summarizes physical properties of each alternative fuel. In this table, heavy oil for ships (HFO), whose lower heating value is 40.4 MJ/kg, CO<sub>2</sub> conversion factor is Cf = 3.114 t-CO<sub>2</sub>/t-Fuel, and specific gravity is 0.94, is used as the benchmark for CO<sub>2</sub> emissions per unit of heat and liquid fuel volume per unit of heat, and they were expressed as a factor of HFO. CO<sub>2</sub> emissions per unit of heat were calculated based on the lower heating value for each fuel presented in the IPCC Guidelines for National Greenhouse Gas Inventories<sup>22</sup> (hereinafter, the "IPCC Guidelines") and the EEDI Calculation Guidelines.<sup>23</sup> Use of the IPCC Guidelines in the creation of national greenhouse gas inventories is required under a decision (Decision 18/CMA.1) made at the 2018 Conference of the Parties serving as the meeting of the Parties to the Paris Agreement.

Table Appendix 2-1: Physical Properties of Alternative Fuels

	Specific gravity (in the liquid form)	Lower heating value [GJ/ton]	CO <sub>2</sub> conversion factor (Cf) (t-CO <sub>2</sub> /t-Fuel)	CO <sub>2</sub> emissions per unit of heat (HFO=1)	Liquid fuel volume per unit of heat (HFO=1)
Hydrogen	0.071	120	0	0	4.46
Ammonia	0.68	20.5	0	0	2.72
LNG	0.48	48.0	2.750	0.74	1.65
Methane	0.422	50.0	2.750	0.71*	1.80
Biodiesel	0.88	27.0	[2.816]	[0]	1.60
Methanol	0.80	19.9	1.375	0.90*	2.39
Ethanol	0.79	26.8	1.913	0.93*	1.79

\*The value for carbon-recycled fuels (synthetic fuels and biofuels) is assumed to be 0. **See Appendix 4** with regards to ideas on emissions from carbon-recycled fuels, etc.

Appendix 2-2 summarizes the features of each alternative fuel. Details of each alternative fuel's physical properties, development status, and other issues are as described below.

<sup>22</sup> 2006 IPCC Guidelines for National Greenhouse Gas Inventories

<sup>23</sup> IMO, 2018 GUIDELINES ON THE METHOD OF CALCULATION OF THE ATTAINED ENERGY EFFICIENCY DESIGN INDEX (EEDI) FOR NEW SHIPS (MEPC.308(73))

Table Appendix 2-2: Physical Properties, Advantages and Disadvantages of Alternative Fuels

	CO <sub>2</sub> emissions per unit of heat <sup>1</sup> (HFO=1)	Liquid Fuel volume per unit of heat <sup>1</sup> (HFO=1)	Advantages	Disadvantages
<b>Hydrogen (H<sub>2</sub>) (including use in fuel cells)</b>	0	4.46	<ul style="list-style-type: none"> <li>- No CO<sub>2</sub> emissions onboard</li> <li>- Used in small boats (hydrogen-mixed fuel combustion engine, fuel cell)</li> <li>- Used in onshore boilers and gas turbines</li> </ul>	<ul style="list-style-type: none"> <li>- Large fuel volume, approx. 4.5 times that of HFO</li> <li>- Technical difficulty in storage stability (-253 °C in liquid state)</li> <li>- Bunkering infrastructure yet to be developed</li> <li>- Immaturity of bunkering technologies</li> <li>- Technical difficulties in combustion control</li> </ul>
<b>Ammonia</b>	0 (N <sub>2</sub> O emissions not considered)	2.72	<ul style="list-style-type: none"> <li>- No CO<sub>2</sub> emissions onboard</li> <li>- Used for combustion in gas turbines</li> </ul>	<ul style="list-style-type: none"> <li>- Large fuel volume, which is approx. 2.7 times that of HFO</li> <li>- NO<sub>x</sub> emissions</li> <li>- N<sub>2</sub>O emissions (its greenhouse effect approx. 300 times stronger than that of CO<sub>2</sub>)</li> <li>- Toxic</li> <li>- Technical challenges in combustion, such as low flammability (without pilot fuels) and difficulties in increasing engine output</li> </ul>
<b>LNG</b>	0.74 (methane slip not considered)	1.65	<ul style="list-style-type: none"> <li>- Already in practical use</li> <li>- Higher in volumetric energy density than hydrogen and others</li> <li>- Minor infrastructure upgrade for synthetic methane and biomethane</li> <li>- Specific regulations for LNG in the IGF Code</li> </ul>	<ul style="list-style-type: none"> <li>- Reduction of CO<sub>2</sub> emissions is limited.</li> <li>- Methane slip</li> <li>- Possible international criticism for the use of fossil fuels</li> </ul>
<b>Methane (CH<sub>4</sub>)</b>	0.71 [0 <sup>2</sup> ] (methane slip not considered)	1.80	<ul style="list-style-type: none"> <li>- Biomethane is treated as carbon neutral under the IPCC Guidelines in use phase.</li> <li>- Technologically feasible as chemically identical to LNG (predominantly methane) already in practical use - Infrastructure for LNG can be used.</li> </ul>	<ul style="list-style-type: none"> <li>- At present, the IPCC Guidelines have no explicit provision defining carbon-recycled methane as carbon neutral.</li> </ul>
<b>Biodiesel</b>	[0]	(1.2 or less)	<ul style="list-style-type: none"> <li>- Biodiesel is treated as carbon neutral under the IPCC Guidelines in use phase.</li> <li>- Combustion with other fuel is at commercial level onshore.</li> </ul>	<ul style="list-style-type: none"> <li>- Technical difficulties in storage stability</li> <li>- Possible low availability for shipping due to high demand in other sectors</li> </ul>
<b>Methanol (CH<sub>3</sub>OH)</b>	0.90 [0 <sup>2</sup> ]	2.39	<ul style="list-style-type: none"> <li>- Biomethanol is treated as carbon neutral under the IPCC Guidelines in use phase.</li> <li>- Methanol-fueled ships have already been delivered.</li> <li>- Easy to handle</li> </ul>	<ul style="list-style-type: none"> <li>- At present, the IPCC Guidelines have no explicit provision defining carbon-recycled methane as carbon neutral.</li> <li>- Large fuel volume, approx. 2.4 times that of HFO</li> <li>- Technical difficulties in ignitability and in increasing engine output</li> </ul>
<b>Ethanol (C<sub>2</sub>H<sub>5</sub>OH)</b>	0.93 [0 <sup>2</sup> ]	1.79	<ul style="list-style-type: none"> <li>- Bioethanol is treated as carbon neutral under the IPCC Guidelines in use phase.</li> <li>- Bioethanol production is at a commercial level.</li> <li>- Easy to handle</li> </ul>	<ul style="list-style-type: none"> <li>- At present, the IPCC Guidelines have no explicit provision defining carbon-recycled methane as carbon neutral.</li> <li>- Technical difficulties in ignitability and in increasing engine output</li> </ul>

1. CO<sub>2</sub> emissions per unit of heat and fuel volume (in the liquefied state) per unit heat were calculated on the basis of heavy oil for ships (HFO) with the lower heating value of 40.4 MJ/kg, the CO<sub>2</sub> conversion factor Cf= 3.114 t-CO<sub>2</sub>/t-Fuel and the specific gravity of 0.94. CO<sub>2</sub> emissions per unit of heat was calculated on the basis of the lower heating value of each fuel presented in the IPCC Guidelines and in the IMO's EEDI Calculation Guidelines.<sup>24</sup>

2. CO<sub>2</sub> emissions generated are counted as 0 (zero) when burning carbon-recycled fuels (artificially produced fuels by separating, capturing, and recycling CO<sub>2</sub>) and biofuels.

3. With respect to the space required in design, factors other than the fuel volume also need to be taken into account for each of these fuels.

<sup>24</sup> 2018 GUIDELINES ON THE METHOD OF CALCULATION OF THE ATTAINED ENERGY EFFICIENCY DESIGN INDEX (EEDI) FOR NEW SHIPS (MEPC.308(73))

## (1) Hydrogen

Hydrogen does not emit CO<sub>2</sub> when burned. Therefore, in Japan and other countries, it is deemed to be a promising fuel that enables carbon reduction in various areas, such as electric power generation, transport, and heat and industrial processes. Its other advantages include that hydrogen produced with surplus electricity from renewable energy sources and its storage enable the expansion of the introduction of renewable energy and that, unlike oil, which is unevenly distributed in the world, hydrogen can be produced from renewable energy and a wide variety of fossil fuels, enabling the reduction of risk in the procurement of primary energy. In addition, even if hydrogen is not used directly as a fuel for ships, it is an important resource related to the manufacturing of ammonia and synthetic fuels.

Hydrogen can be used as an energy source for a reciprocating engine and fuel cells. In the maritime sector, hydrogen has been used for small ships with engines using hydrogen mixed fuels and for hydrogen fuel cell powered ships.<sup>25,26</sup> In the onshore sector, continuous combustion technologies for boilers, gas turbines, and other equipment are being proactively developed and have been applied in many projects.<sup>27</sup> Appendix 2-3 summarizes features of power sources that use hydrogen as a fuel.

Methods for direct storage and transport of hydrogen include one involving liquid hydrogen and one using high-pressure tanks. The research and development of technologies for adsorbing hydrogen onto other substances or transforming it into other substances is also being conducted. Methods of storing hydrogen with a hydrogen storage alloy and of transporting hydrogen by transforming it into ammonia, organic hydrides, or other substances have been suggested, and some of them are being developed or commercialized.<sup>28</sup> Information about ammonia will be described later separately. Regardless of methods, the development of infrastructure to supply ships and the development and establishment of bunkering technologies are required. Features of each hydrogen storage technology are summarized in Table Appendix 2-4.

---

<sup>25</sup> CMB, <http://www.hydroville.be/en/hydroville/> and Water-GO-Round, <https://watergoround.com/>.

<sup>26</sup> Water-GO-Round, <https://watergoround.com/>.

<sup>27</sup> NEDO: *Suiso Hatsuden - Power to Gas (P2G) Bunya* (Hydrogen power generation – power to gas field), <https://www.nedo.go.jp/content/100895064.pdf>.

<sup>28</sup> Segawa, A: *Yuuki hydride kara-no kou jundo suisu kaishu gijutsu kaihatsu* (Development of a technology for recovering highly pure hydrogen from organic hydride), ENEOS Technical Review, Vol. 52, No.1, 2010



Table Appendix 2-3: Features of power sources that use hydrogen as a fuel

Type	Features
Reciprocating engine	<ul style="list-style-type: none"> <li>• There exist small ships with engines using hydrogen-mixed fuels.</li> <li>• There is a plan in Japan to install engines using hydrogen-mixed fuel on small ships<sup>29</sup>.</li> <li>• Hydrogen co-combustion up to 30% to 50% are considered relatively easy to realize.</li> <li>• Hydrogen-fueled engines require combustion control technologies due the small minimum ignition energy and high combustion speed.</li> <li>• Materials applicable for the engine are limited because of hydrogen brittleness.</li> <li>• Hydrogen purity could be lower than that used for fuel cells, leading to cost reduction.</li> <li>• NO<sub>x</sub> emissions are higher than those from LNG-fueled lean-burn engines.</li> <li>• Exhaust gas may contain unburned hydrogen. However, as it would be lower than the lower explosive limit (LEL) of 4% for hydrogen, major safety issues and environmental impacts are not expected.</li> <li>• With premixed combustion engines, the leakage of hydrogen into the crankcase (blow-by gas) could be a problem.</li> </ul>
Fuel cell	<ul style="list-style-type: none"> <li>• Some fuel cells for automobiles (which directly use hydrogen) is commercially available.</li> <li>• Verification tests of hydrogen fuel cell ships and similar plans are in progress.</li> <li>• Energy efficiency is equal to or higher than internal combustion engines currently used.</li> <li>• Challenges in responding to load changes</li> <li>• Higher purity hydrogen than that used in engines is necessary.</li> <li>• Electric propulsion system with fuel cells require a larger motor, leaving an issue in installation. In case of large ships, a motor with high power output needs to be developed.</li> <li>• No NO<sub>x</sub> emission in general. (Solid electrolyte fuel cells generate a tiny amount of NO<sub>x</sub> because of high-temperature reaction.)</li> <li>• Surplus hydrogen needs to be treated. (Normally not a problematic level)</li> </ul>
Gas turbine	<ul style="list-style-type: none"> <li>• Demonstration plant of 1 MW class hydrogen turbine generator has been developed.</li> </ul>
Boiler	<ul style="list-style-type: none"> <li>• Hydrogen mixed combustion boilers are commercially viable.</li> </ul>

<sup>29</sup> Tsuneishi Facilities & Craft Co., Ltd., <https://www.tsuneishi-g.jp/news/topics/2019/08/26601>.

Appendix 2-4: Features of hydrogen storage technologies

Type	Features
Liquid hydrogen	<ul style="list-style-type: none"> <li>• The storage tank needs to be approx. 4.5 times larger than that for HFO to have same amount of heat.</li> <li>• Treatment / use of boil-off gas (BOG) is possible.</li> <li>• Because of the low specific gravity, it is difficult to increase pressure with a pump.</li> <li>• Heat exchanger needs to be large because of its latent heat higher than natural gas.</li> <li>• Gas sealing needs to be done carefully.</li> <li>• A high level of heat insulation technology and sealing technology are necessary because of its extremely low temperature, around 20 K (-253 degrees Celsius).</li> </ul>
High-pressure tank	<ul style="list-style-type: none"> <li>• High-pressure tanks (approx. 35 to 70 MPa) are used for fuel cell vehicles.</li> <li>• The use of high-pressure hydrogen in high-pressure cylinders is presumed for small- and medium-sized ships, but not applicable for long-distance navigation. Onshore infrastructure will be necessary.</li> <li>• Limitations in tank capacity due to required strength</li> <li>• Large ancillary equipment, such as safety valves, need to be developed.</li> </ul>
Hydrogen storage alloy	<ul style="list-style-type: none"> <li>• Storage efficiency is low.</li> <li>• Supplying fuel is likely to take long time. In addition, because an exothermic reaction occurs while fuel (hydrogen) is supplied to hydrogen storage alloy, temperature control could be necessary.</li> <li>• Storage quantity per weight is small. Its energy density is as small as 0.1 times that of methylcyclohexane (MCH). Accordingly, application in ships is difficult.</li> <li>• Because an endothermic reaction occurs when hydrogen is extracted from the alloy for use as fuel, temperature control of heating and other equipment could be necessary.</li> <li>• Research and development of new hydrogen storage substances are in progress.</li> </ul>
Organic hydride	<ul style="list-style-type: none"> <li>• If MCH, etc. is used, onshore infrastructure will need to be developed.</li> <li>• Calculated based on the heat generation rate of hydrogen, the tank capacity needs to be approx. 7 times larger than current capacity for HFO (in the case of mono-fuel engines).</li> <li>• Hydrogen separator is necessary.</li> <li>• The efficiency of hydrogen storage and dehydrogenation reactions need to be improved.</li> </ul>

## (2) Ammonia

Like hydrogen, ammonia (NH<sub>3</sub>) is deemed to be a promising carbon-free fuel that does not emit CO<sub>2</sub> if being used without pilot fuels. While the research and development of dual-fuel reciprocating engines, gas turbines, and fuel cells is under way in Japan and other countries, a power system which uses ammonia as a fuel has yet to be put to practical use at present. Compared to hydrogen, ammonia is easy to store in liquid form. In addition, existing cargo-handling technologies can be used for bunkering.

There is a plan to develop a 2-stroke engine that uses ammonia in coming years.<sup>30</sup>, using a fuel injection system similar to dual-fuel engines powered by LPG and HFO. LPG is a gas whose main component is propane or butane, and it can be liquefied under pressures and temperature conditions similar to those for ammonia. Therefore, ammonia can be handled easily at LPG facilities if countermeasures against its corrosiveness is taken.

As to gas turbines using ammonia as fuel, the research and development of ammonia gas turbines was

<sup>30</sup> R. S. Laursen, "Ship Operation Using LPG and Ammonia as Fuel on MAN B&W," in NH<sub>3</sub> Fuel Conference 2018, Pittsburgh, 2018.

conducted from fiscal year 2014 to 2018 as part of research and development into the direct combustion of ammonia in the Cross-ministerial Strategic Innovation Promotion Program (SIP) "Energy Carriers".<sup>31</sup> This included individual research and development projects on combustor used in gas turbines, as well as the demonstration of a 50 kW gas turbine power generation by using 100% ammonia. In addition, the use of ammonia in fuel cells (SOFC) is also expected, and research and development efforts to this end are in progress, although they face issues related to catalyst technology and temperature control.<sup>32</sup>

On the other hand, the combustion reactivity of ammonia is lower than that of other fuels, which makes mono-fuel combustion difficult. This property also makes it likely that unburned ammonia and NO<sub>x</sub> will be generated during combustion. In addition, its toxicity to humans is also regarded as an issue to be addressed. Further, use of ammonia can result in the generation of nitrous oxide (N<sub>2</sub>O), whose greenhouse effect is considered to be 300 times higher than CO<sub>2</sub>. Accordingly, studies to grasp the actual situation and the development of technologies to solve these issues are necessary.

### **(3) Liquefied Natural Gas (LNG)**

Natural gas is a flammable gas that is mined from the earth. In many cases, it is mined purely from a gas field or as an associated gas in crude oil production. On the other hand, gas extracted from shale formations (shale gas), which had previously been difficult to mine, has also begun to be used.

The properties of natural gas differ by production area. However, wherever it is produced, its main component is methane, and other components include hydrocarbons such as ethane, propane, and butane, as well as impurities such as water, oxygen, nitrogen, carbon dioxide, and hydrogen sulfide. When natural gas is liquefied for storage or transport, impurities are usually isolated and removed in the pre-treatment process because they cause the clogging of liquefaction equipment and corrosion in gas facilities. This process significantly reduces the impurities contained in LNG, allowing it to be used as a cleaner fuel.

Engines and ships using LNG fuels are already in practical use, and related rules have been developed by the IMO.

Other features of LNG include its energy volume density, which is higher than hydrogen and other substances, and the fact that the related equipment and infrastructure can be converted easily for the use of carbon-recycled fuels and biomethane fuels, which are described below.

On the other hand, the CO<sub>2</sub> reduction potential of LNG is limited, being 26% reduction compared to emissions from HFO. (See Table Appendix 2-1.) In addition, when LNG is used in internal-combustion engines, it is necessary to consider the assessment of methane slip and the countermeasures for the issues identified.

---

<sup>31</sup> SIP Energy Carriers "Ammonia Chokusetsu Nensho (direct ammonia combustion)": A report on completion of technology development for ammonia gas turbine co-generation, <https://www.jst.go.jp/sip/dl/k04/end/team6-5.pdf>.

<sup>32</sup> Cross-ministerial Strategic Innovation Promotion Program: <https://www.jst.go.jp/pr/announce/20170703-2/index.html> (Referred to in February 2019)

#### **(4) Carbon-recycled fuels (synthetic fuels)**

While carbon-free fuel generally refers to an energy carrier (e.g. hydrogen) produced without involving hydrocarbons in its process, carbon-recycled fuel refers to a synthetic fuel produced from the captured CO<sub>2</sub> and hydrogen. These fuels are also called e-fuel (electro-fuel), e-gas, e-diesel, when the hydrogen was produced from electricity.

Among the carbon-recycled fuels, ones that are being used or expected to be usable for ships include methane, methanol, ethanol, and dimethyl ether (DME). While these fuels generate CO<sub>2</sub> during combustion, additional CO<sub>2</sub> emissions to the atmosphere can be inhibited because these carbons derive from the captured CO<sub>2</sub>. Although the IPCC Guidelines have no explicit provision defining carbon-recycled fuels as carbon neutral, synthetic fuels produced by the captured CO<sub>2</sub> emitted from land-based activities could be regarded as carbon-neutral fuel, as the captured CO<sub>2</sub> accounts for emissions by the production stage, not by the combustion stage. (This is the interpretation used in the Project based on the IPCC Guidelines. **See Appendix 4.**)

For carbon-recycled methane, technologies for LNG, which have already been put to practical use, can be applied to ships using carbon-recycled methane fuel because its chemical property is basically identical to that of LNG. Existing infrastructure for LNG can also be converted to the use for carbon-recycled methane. As for carbon-recycled methanol, as methanol is easy to handle and methanol-fueled ships have already been delivered, it also will be one of promising alternative fuels for ships.

#### **(5) Biofuels**

Biofuels are regarded as carbon-neutral fuels, according to the IPCC Guidelines. They include biodiesel (BDF, FAME), which is produced from rapeseed oil, soybean oil, palm oil, used food oil, or other oils through esterification. In addition, fuels such as methane, methanol, and ethanol can also be produced from biomass. The production of biodiesel and bioethanol is commercially viable. Most commonly, the mixed combustion of biodiesel is used commercially in the onshore sector.

On the other hand, biofuels are easily oxidizable compared to petroleum, which makes long-term storage an issue. In addition, supply capacity is limited, and it is expected that the demand from the onshore and aviation sectors will increase. Therefore, it is uncertain whether there will be sufficient supply of these fuels to meet the demand of the shipping sector in the future.

## 2. Feasibility of GHG Reduction Technologies

Major GHG reduction technologies other than alternative fuels include wind propulsion, battery propulsion, and onboard CO<sub>2</sub> capturing. Features of these technologies are summarized in Table Appendix 2-4.

Table Appendix 2-4: Characteristics of GHG Reduction Technologies

	Potential for efficiency improvement	Advantage	Disadvantage
<b>Wind propulsion</b>	Dependent on the extent of use	- Zero emissions onboard	- It cannot be used as a main source for propulsion for reasons of scale.
<b>Solar cells</b>	Dependent on the extent of use	- Zero emissions onboard	- It cannot be used as a main source for propulsion for reasons of scale.
<b>Air lubrication</b>	Around 2% to 6%	- Technologies available	- The effect varies depending on the hull form and the operation status.
<b>Low friction paints</b>	Around 2% to 5%	- Technologies available	- The effect varies depending on the hull form and the operation status.
<b>Energy efficient ducts</b>	Around 2% to 5%	- Technologies available	- The effect varies depending on the hull and stern forms and the operation status.
<b>Bow form change</b>	Around 2% to 5%	- Technologies available	- The effect varies depending on the hull and bow forms and the operation status.
<b>Exhaust heat recovery system for generation of electricity</b>	Around 1% to 5%	- Technologies available	-
<b>Battery propulsion</b>	Dependent on the extent and method of use	- Zero emissions onboard - Implemented as the main propulsion system in some small boats and as an auxiliary propulsion system in some larger ships	- Low weight and volumetric energy density - High voltage recharging infrastructure underdeveloped - Longer charging time required than conventional fuel bunkering
<b>Onboard CO<sub>2</sub> capturing</b>	Capturing at least 85% of CO <sub>2</sub> in exhaust gas	- Compatible with any fuel oil/gas (in theory) - Reduction at a considerable rate (in theory)	- No track record of implementation onboard - Exhaust gas pre-treatment (such as denitration and desulfurization) required depending on the type of fuel - Large volume and weight of CO <sub>2</sub> after capturing

### (1) Onboard CO<sub>2</sub> Capturing

Onboard CO<sub>2</sub> capturing is a technology for isolating and capturing CO<sub>2</sub> contained in the exhaust gasses of thermal engines. This technology has yet to be applied in the shipping sector. However, in the onshore sector, relevant technologies are already in practical use, or demonstration or pilot projects have been conducted. These technologies include carbon dioxide capture and storage (CCS), which isolates and captures CO<sub>2</sub> emitted from a power plant, chemical plant or similar facility and stores it in the ground or other place, and carbon dioxide capture, utilization and storage (CCUS), which is applied to use the captured CO<sub>2</sub>. They have been put into practical use or are in advanced stages of verification projects, both in Japan and other countries.

There are several methods for capturing CO<sub>2</sub>. Potential technologies for onboard CO<sub>2</sub> capturing are as summarized in Table Appendix 2-5. In membrane separation, a membrane which enables the selective separation of CO<sub>2</sub> is used. This method has a feature of lower energy consumption than other methods

for isolation and capturing.<sup>33</sup>

Adsorption separation is a method in which CO<sub>2</sub> is adsorbed by adsorbing material, such as porous zeolite.<sup>34</sup> This process consumes a certain amount of energy because CO<sub>2</sub> adsorption and isolation are driven by differences in pressure or temperature. However, this method permits storage at an ordinary temperature and has other features.

Absorption separation is a method in which CO<sub>2</sub> is chemically absorbed into an absorbent. Amine-based solution is used as absorbent in many cases.<sup>35</sup> This method also permits storage at an ordinary temperature after absorption. It has superior features, including the potential for capturing 85% or more emitted CO<sub>2</sub>. On the other hand, CO<sub>2</sub> absorption and isolation require energy consumption to generate the difference in pressure or temperature. Therefore, research and development into an absorbent that would reduce this energy consumption is being conducted at present, and a demonstration plant using this absorbent is operating.

A promising way of storing the captured CO<sub>2</sub> is to store it in the form of a single component, gas and solid, or a multicomponent liquid containing CO<sub>2</sub>. (See Table Appendix 2-6.) As a single component, CO<sub>2</sub> can be stored in the form of either dry ice or a liquid (triple point: -56.6 degrees Celsius, 0.52 MPa or above) or in the supercritical state (31.1 degrees Celsius, 7.4 MPa or above), all of which involve energy consumption. Where CO<sub>2</sub> is loaded onboard a ship as gas and solid or multicomponent liquid, the issues are weight reduction of the absorbent or adsorption material and the increase of the amount of CO<sub>2</sub> absorption or adsorption per unit volume.

Issues involved in onboard CO<sub>2</sub> capturing include that the treatment of exhaust gases (such as denitration, desulfurization, and dust removal) is necessary depending on the type of fuel or the method of CO<sub>2</sub> capturing. The high volume and weight of the captured and stored CO<sub>2</sub> (which is around 4 times higher than HFO when CO<sub>2</sub> is stored in liquid form) is also an issue to be addressed. Onboard CO<sub>2</sub> capturing also requires the development of technologies, including ones for reducing the costs of onboard CO<sub>2</sub> capturing system for ships and the development of infrastructure for unloading CO<sub>2</sub> to land, the establishment of technologies for converting the captured CO<sub>2</sub> back to fuel by methanation or other methods, and the development of a mechanism to facilitate re-use of the captured CO<sub>2</sub>.

---

<sup>33</sup> Kai, T.: Development of novel CO<sub>2</sub> separation membranes and scale-up for commercialization, Vol.35, No.4, pp.194-200, 2010.

<sup>34</sup> Minemoto, M. and Matsukuma, Y.: Optimization of CO<sub>2</sub> removal and concentration system by using of honeycomb adsorbent, G-COE Program Kyushu University Novel Carbon Resource Sciences

<sup>35</sup> Kitamura, H., Egami, N., and Ohashi, Y.: Validation testing of carbon dioxide capture pilot plant using flue gas of coal-fired thermal power plant, TOSHIBA REVIEW, Vol.65, No.8, pp.31-34, 2010.

Table Appendix 2-5: Potential Technologies for Onboard CO<sub>2</sub> Capturing

Carbon capture method	Required amount of energy	Status of development	Remarks
Membrane separation	Small	Separation membranes are being developed.	Polymer membrane, ionic liquid membrane, etc.
Adsorption separation	Medium	Method for high-concentration CO <sub>2</sub> has been commercialized, and one for low-concentration CO <sub>2</sub> is being developed.	Water needs to be removed in advance.
Liquid absorption separation	Large (heat)	An absorbent that requires small amount of energy is being developed.	A demonstration plant is operating.
Solid absorption separation	Medium (heat)	Absorbent and adsorbent are being developed.	Amine compound, porous simple substance

Table Appendix 2-6: Types and Features of CO<sub>2</sub> Storage Technologies

State	Content	Required amount of energy	CO <sub>2</sub> purity
Single component	Dry ice, liquid CO <sub>2</sub> , or supercritical CO <sub>2</sub>	Medium	High
Gas and solid	Solid containing CO <sub>2</sub> (adsorbent or absorbent)	Small	High
Multicomponent liquid	Absorbent that has absorbed CO <sub>2</sub> , and water	Small	Medium

## (2) Wind Propulsion

This method uses wind energy, which is proportional to the cube of wind speed. The development of technology for various systems is in progress, including soft sails, solid sails, rotor systems, and towing kite. In Europe, several domestic vessels, including a Ro-Ro ship and a ferry, are being operated with wind propulsion systems, and preparations for the demonstration of an ocean-going vessel are also under way. In Japan, several projects for installing wind propulsion systems on ships have been initiated.<sup>3637</sup>

Wind propulsion is one of promising GHG reduction technologies, as natural renewable energy is used directly. However, as the performance of wind propulsion depends on wind condition, wind propulsion

<sup>36</sup> Mitsui O.S.K. Lines, Ltd., <https://www.mol.co.jp/pr/2019/19074.html>

<sup>37</sup> Kawasaki Kisen Kaisha, Ltd., <https://www.kline.co.jp/ja/news/csr/csr-2630416184971214499/main/0/link/190607JP.pdf>

needs to be combined with engine propulsion to maintain the propulsion performance of the ship. Accordingly, it is expected to be used as supplementary propulsion energy to assist the main propulsion system. Its GHG reduction effect varies according to the type of ship to which it is introduced, the wind propulsion system, route, season, weather, and other factors. A study reports<sup>38</sup> that wind propulsion can reduce GHG emissions from ships using HFO by 1% to 23%.

Wind propulsion is an established technology, and thus it is likely to be introduced to ocean-going ships early. However, it involves issues such as high initial costs, sail handling during cargo handling, deployment and collection of the kite during navigation, and restrictions on upper deck structures and cargo handling equipment. The introduction of wind propulsion systems would be limited to some types of ship due to these issues.

### **(3) Solar Cells**

Solar cells are electric power generator which directly convert sunlight energy into electricity. The solar cells that are in practical use at present are largely categorized to silicon solar cells, compound cells, organic cells, etc. They are classified further according to the material of the light-absorbing layer, the shape of the elements, and other attributes.

The energy conversion efficiency of the solar cells which are used widely at present is around 15% to 20%. Research and development projects aimed at improving efficiency to 40%, such as ones developing multi-junction compound semiconductor solar cells, are being implemented.<sup>39</sup>

On ships with enough space for installing solar cells, this technology would be effective for reducing GHG emissions if the generated power is used appropriately.

On the other hand, solar cells require sunlight, which means that power is generated only in the daytime. It is impossible to stabilize the output of the power generated without other technologies as the incoming sunlight fluctuates throughout the day. Therefore, on ships, solar cells must be used together with secondary batteries, and charging equipment (converters) for the batteries is also necessary, resulting in high initial costs. It should be noted that, even if solar cells with an energy conversion efficiency of 40% or higher are put to practical use and used widely, it will remain difficult to obtain all propulsion power needed by ships from solar cells alone.

### **(4) Propulsion with secondary batteries**

At present, the use of secondary batteries, such as nickel-metal hydride batteries, lithium ion batteries, sodium-sulfur batteries, and supercapacitors, is spreading in the onshore sector. Promising next-generation secondary batteries include solid-state lithium batteries and metal-air batteries such as lithium-air batteries, zinc-air batteries, and aluminum-air batteries. Table Appendix 2-7 summarizes the

---

<sup>38</sup> CE Delft: Study on the analysis of market potentials and market barriers for wind propulsion technologies for ships, 2016.

<sup>39</sup> New Energy and Industrial Technology Development Organization: NEDO PV Challenges, 2014, <https://www.nedo.go.jp/content/100575154.pdf>



features and development trends of major next-generation batteries.<sup>40</sup>

Secondary batteries have also been used in the shipping sector for the main propulsion system of small ships or for auxiliary propulsion system of larger ships.

An issue of these secondary batteries is their low weight and volume energy density. The weight and volume energy density of existing secondary batteries is tens of times smaller than that of HFO. The weight and volume energy density of next-generation secondary batteries, which will be widespread from 2030 onward, is expected to be one-sixth to one-tenth that of HFO.

Secondary batteries are an ideal technology in that no GHG or other gases are emitted from ships. However, it involves issues such as the development of infrastructure for high-voltage charging and the time required for charging, which is longer than the time normally required for HFO bunkering. It is therefore likely to be difficult to apply this technology to ships which travel long distances compared to ships engaged in relatively short-distance travel.

Table Appendix 2-7: Features and Development Trends of Major Next-generation Storage Batteries

		(Metal) Air battery	Solid-state battery
Material	Positive electrode (Cathode)	Ambient air (oxygen), electroconductive porous materials (such as carbon)	Lithium oxide (such as Lithium-cobalt oxide and Lithium-nickel-cobalt-manganese oxides)
	Negative electrode (Anode)	Lithium metal, zinc, aluminum, magnesium, iron	Carbon, alloys (such as lithium)
	Mediator	Electrolyte, electrolytic solution, etc.	Solid electrolyte
Characteristics	Advantages	<ul style="list-style-type: none"> <li>- High energy density (1 kWh/kg or above)</li> <li>- Materials with large reserves can be used. (Materials are easy to procure.)</li> <li>- Unlikely to cause a fire</li> </ul>	<ul style="list-style-type: none"> <li>- High energy density (800 Wh/kg or above)</li> <li>- High output</li> <li>- Shorter charging time</li> <li>- Higher level of safety (no liquid spills or fires)</li> </ul>
	Issues	<ul style="list-style-type: none"> <li>- Performance of positive electrode needs to be improved.</li> <li>- Durability of electrolytic solution</li> <li>- Regeneration of electrode</li> </ul>	<ul style="list-style-type: none"> <li>- Discovery and mass production of solid electrolyte with low lithium-ion transfer resistance</li> <li>- Bonding of electrode materials with solid electrolyte</li> </ul>
Status of development		<ul style="list-style-type: none"> <li>- Have been put to practical use as zinc-air batteries and magnesium-air batteries (both of which are used as primary batteries)</li> <li>- Research in their use as secondary batteries is in progress.</li> </ul>	<ul style="list-style-type: none"> <li>- Researches for solid electrolytes and bonding technologies are under way.</li> </ul>

<sup>40</sup> Kanno, R. and Kato, Y.: *Jisedai denchi wo kenin suru zenkotai denchi kaihatsu* (development of solid-state battery which leads next-generation batteries), Nature Energy, AUTHOR INTERVIEW, Vol.1, No.4, 2016.

## (5) Other GHG Reduction Technologies

Other GHG reduction technologies include air lubrication, low-friction coating, energy-saving ducts, changing bow shapes, and waste heat recovery power generators.

Air lubrication is a technology which covers ships' hull surface with an even layer of air bubbles to reduce frictional resistance. In a verification test of this technology, there is a confirmed case that a net energy-saving effect of approx. 6% was measured.<sup>41</sup> The energy-saving effect of this technology is low for deep-draft ships but high for shallow-draft and wide flat bottom ships. This technology is expected to effectively reduce CO<sub>2</sub> emissions from some types of ships.

Low friction coating is a paint for reducing the friction between the coated hull surface and seawater. They have been developed and commercialized by various paint makers. While its effect varies depending on hull shape and operational condition of a ship, a 2% to 5% reduction of CO<sub>2</sub> emissions is estimated to be possible according to the results of demonstrations.<sup>42</sup> The Weather Adapted Duct (WAD), the stern-duct energy-saving device shown in Figure Appendix 2-3, is an energy-saving duct mounted immediately before the propeller at the stern. As of March 2016, WADs have been installed on 110 ships. The effect of this device is not great for slender ships. For fat ships, it was estimated to be able to reduce CO<sub>2</sub> emissions by approx. 5% in a tank test. The technology is therefore expected to be effective depending on the ship type.

Ship resistance can also be reduced by changing the bow shape.<sup>43</sup> While the effect varies according to hull shape and operational condition of a ship, it is roughly estimated to be able to further reduce CO<sub>2</sub> by around 5%.

Waste heat recovery is the system for generating steam by waste heat from engine and thereby driving steam turbines for generation of electricity, resulting in reduction of fuel consumption of auxiliary engines. Existing technologies can be used in waste heat recovery power generators. It is estimated to be able to reduce CO<sub>2</sub> by roughly 1% to 5%.

---

<sup>41</sup> Kamiirisa, H. et al.: An energy saving technique for ships by air lubrication system, Papers of National Maritime Research Institute, Vol.14, No.2, pp.135-156, 2014, [https://www.nmri.go.jp/en/\\_src/26928/PNM21140206-00.pdf](https://www.nmri.go.jp/en/_src/26928/PNM21140206-00.pdf)

<sup>42</sup> Yano, Y. et al.: Energy saving of actual ship by the new anti-fouling bottom paint, Review of the Faculty of Maritime Sciences, Kobe University, No.9, pp.79-87, 2012, <http://www.lib.kobe-u.ac.jp/repository/81003940.pdf>

<sup>43</sup> Sakurada, A. et al.: Development of COVE bow -- Energy saving bow shape in actual seas, Kaijo Gijutsu Anzen Kenkyusho dai 16-kai Kenkyu Happyo-kai Kouen-shu (proceedings of the 16<sup>th</sup> research presentation meeting of the National Maritime Research Institute), 2016, <https://www.nmri.go.jp/oldpages/main/publications/paper/pdf/2B/16/00/PNM2B160003-00.pdf>



Figure Appendix 2-3: WAD Mounted on a Ship<sup>44</sup>

---

<sup>44</sup> Kawashima, H. et al.: Research on the development of energy saving device in actual sea, Papers of National Maritime Research Institute, Vol.17, No.1, pp.73-86, 2017.

## **Appendix 3. Ultra-low or Zero Emission Ships**

### **1. Hydrogen-Fueled Ships**

#### **(1) Concept Design**

##### A. Overview

For a 20,000 TEU container ship and an 80,000 DWT bulk carrier using hydrogen gas engines as the main or auxiliary engines, the types and locations of fuel tanks needed for liquified hydrogen fuel, and ancillary equipment such as fuel supply and bunkering systems that would be necessary for a hydrogen-fueled ship were considered. Other technical issues were also identified.

##### B. Hydrogen fuel

Hydrogen has extremely low boiling point (-253 °C), low ignition energy, wide combustion range, low visibility of flames, high permeability, and it causes hydrogen embrittlement of metal. These characteristics of hydrogen should be duly taken into account in designing equipment and configurations of Hydrogen-fueled ships.

##### C. Selection of a hydrogen storage method

Liquified hydrogen was the hydrogen carrier adopted for this concept design. Due to its low density requiring larger volume for the same amount of energy, hydrogen requires a larger-capacity fuel tank than methane and other fuel oils or gases. In general, a small fuel tank capacity is preferable as it affects the available cargo space. In order to keep hydrogen density relatively higher and reduce the fuel tank capacity, hydrogen needs to be cooled to -253 °C to be liquefied and compressed to 1/800 of its volume as a gas. Volume efficiency is the benefit of liquefied hydrogen.

Under the low temperature of -253 °C, the purity of hydrogen is high because the impurities have solidified. Further, liquefied hydrogen is not toxic or odoriferous and does not contain any greenhouse gases. It can be used as fuel directly after being gasified with an evaporator, with no need for dehydrogenation, refinement, or other processes. These points are also beneficial in situations where the space for installing equipment is limited, such as on a ship.

The use of liquefied hydrogen as fuel has certain challenges, such as the necessity of developing large, heat-insulated tanks compatible with the ultra-low temperatures and the need to reduce the energy required for liquefaction. However, the equipment basic configuration for fuel supply is similar to that for LNG-fueled/ LPG-fueled ships, which means that existing technologies can be drawn on for the developments.

##### D. Basic policy for the concept design

In developing the concept design, the requirements, constraints, and other conditions of the hydrogen-fueled ships were not significantly changed from those of currently operated container ships and bulk carriers. Based on that, necessary arrangements were considered in changing the fuel from oil or natural

gas to hydrogen.

#### E. Hydrogen bunkering locations

Figure Appendix 3.1-1 shows the hydrogen bunkering bases assumed for this concept design. It was assumed that there would be five liquefied hydrogen bunkering bases globally, in Europe, the Middle East, Australia, Japan and South America.

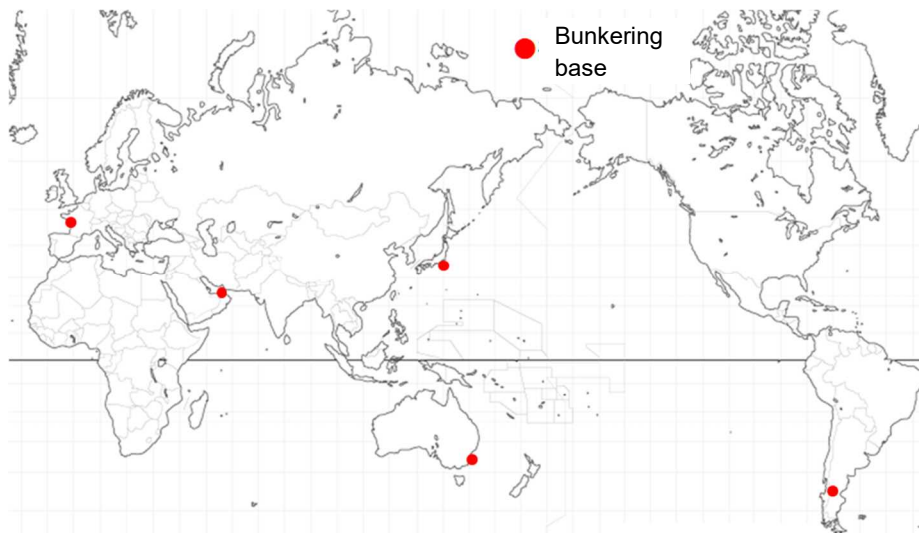

Figure Appendix 3.1-1: Hydrogen Bunkering Bases

#### F. Routes and cruising distance

The cargo and routes of 80,000 DWT bulk carriers are rarely restricted. Therefore, for this concept, it was assumed that the bulk carrier transports cargo passing through as many of the hydrogen bunkering bases shown in Figure Appendix 3.1-1 as possible. The cruising distance of the 80,000 DWT bulk carrier was set as 7,000 NM in light of the following major routes.

##### Major routes

- Japan - Australia: Approx. 5,200 NM
- Middle East - Europe: Approx. 4,400 NM
- Japan - Middle East: Approx. 6,800 NM
- Europe - South America: Approx. 6,900 NM

The regular route shown in Figure Appendix 3.1-2 was assumed for the 20,000 TEU container ship. The route travels between Japan and Europe via the East China Sea, Straits of Malacca, Indian Ocean, Suez Canal, Mediterranean Sea, Straits of Gibraltar, and Celtic Sea. Because both Japan and Europe are bunkering locations, a 11,500 NM one-way cruising distance was set.

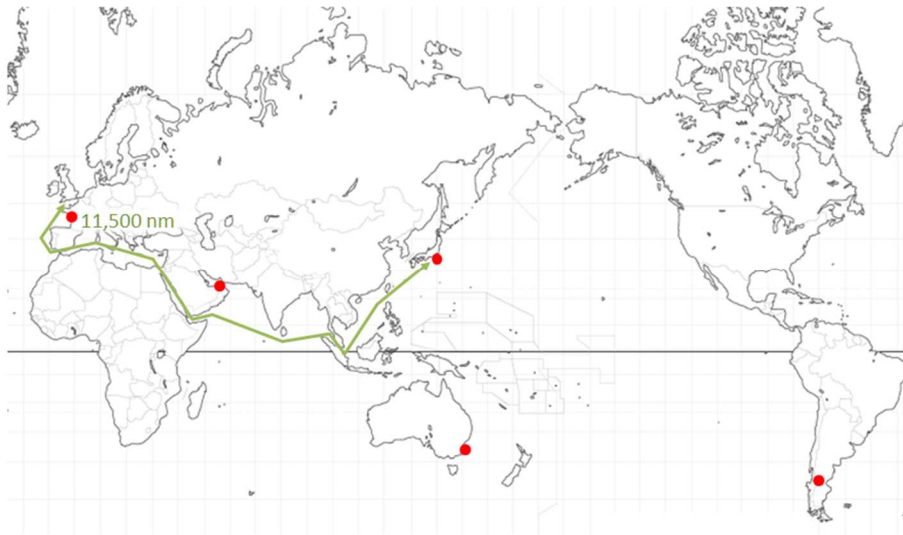

Figure Appendix 3.1-2: Container Ship Route

### G. Hydrogen-fueled engine

Dual fuel reciprocating engines, which are assumed to achieve high thermal efficiency as hydrogen gas combustion engines, were selected as the main propulsion and auxiliary engines to be installed in the hydrogen-fueled ships.

The basic concept of the propulsion system is that the propulsion equipment configuration of a dual fuel reciprocating engine powered by natural gas will be maintained and inherited without change, with a conversion from natural gas to hydrogen fuel. The dual fuel engine can continue operation by switching to low-sulfur fuel oil when the cruising conditions or engine conditions do not permit the use of hydrogen fuel.

There are two methods of combusting hydrogen gas in an engine: lean premixed combustion (Otto cycle) and directly injected diffusion combustion (diesel cycle). Although both methods can be applied, this concept design assumed an Otto-cycle engine based on the following points.

- For the engine to consume the boil-off hydrogen gas generated in the liquefied hydrogen fuel tanks without wasting it, hydrogen gas needs to be compressed before being supplied.
- The volume heating value of hydrogen gas is low, resulting in very large volume of the supplied fuel. Accordingly, the power needed to compress hydrogen gas is expected to be extremely high.
- The Otto cycle permits the use of hydrogen gas as fuel even when it is supplied at relatively low or medium pressure.

Technological issues to be addressed in the lean premixed combustion of hydrogen gas are the abnormal combustion (knocking) attributed to the high speed of the propagation of hydrogen combustion and the extremely small ignition energy, as well as the expected increase in the amount of thermal  $\text{NO}_x$  generated and emitted, which is attributed to the high combustion temperature of hydrogen. Therefore,

the installation of an exhaust gas recirculation (EGR) system was planned as a means of controlling the above phenomena effectively. In addition, the combustion pressure in the cylinder was set slightly lower than the current natural gas engine used for the lean premixed combustion system. In this case, thermal efficiency is expected to be slightly lower than that of the current natural gas engine. However, it is assumed to be technically feasible that a hydrogen engine achieves thermal efficiency equivalent to or better than other engines existing today.

The piping system to supply hydrogen gas to the engine is a double-pipe system which keeps all pipes, including the ones attached to the engine, at a negative pressure by means of forced ventilation through exhaust. This design enables the safe handling of hydrogen gas leaks.

Appendix 3.1-1 (main engine for propulsion) and Appendix 3.1-2 (auxiliary engine for power generation) summarize the main engine specifications for the aforementioned dual-fuel reciprocating engine using hydrogen gas installed in an 80,000 DWT bulk carrier and a 20,000 TEU container ship.

Main propulsion engine: low-speed, 2-stroke engine

- Dual-fuel, low-speed, 2-stroke engine which uses hydrogen gas and low-sulfur distillate oil (lean premixed combustion)
- Lean premixed hydrogen gas is ignited with a tiny amount of micro pilot oil (low-sulfur distillate oil).
- In-cylinder pressure setting and installation of EGR to avoid knocking caused by hydrogen gas combustion
- Installation of EGR to control the increase of NOx emissions from hydrogen gas combustion

Appendix 3.1-1: Core Specifications of Main Propulsion Engines Powered by Hydrogen Fuel

Item	Unit	80,000 DWT bulk carrier	20,000 TEU container ship	Remarks
Maximum output	kW	8,000	60,000	
Rated rotating speed	rpm	84	80	
Fuel consumption rate	kJ/kWh	7,830		
Total length	mm	10,700	25,500	
Total width	mm	8,200	11,500	
Height	mm	10,400	15,300	

### Auxiliary engine: medium-speed, 4-stroke engine

- Dual-fuel, medium-speed, 4-stroke engine (lean premixed combustion) powered by hydrogen gas and low-sulfur distillate oil
- Lean premixed hydrogen gas is ignited with a tiny amount of micro pilot oil (low-sulfur distillate oil).
- In-cylinder pressure setting and installation of EGR to avoid knocking caused by hydrogen gas combustion
- Installation of EGR to control the increase of NOx emissions from hydrogen gas combustion

Appendix 3.1-2: Main Specifications of Auxiliary Power Generation Engines Powered by Hydrogen Fuel

Item	Unit	80,000 DWT bulk carrier	20,000 TEU container ship	Remarks
Maximum power generation output	kWe	1,000	5,000	
Rated rotating speed	rpm	720	600	
Fuel consumption rate	kJ/kWh	9,000	8,000	
Total length	mm	6,800 <sup>1</sup>	8,800	
Total width	mm	2,000 <sup>1</sup>	3,500	
Height	mm	3,500 <sup>1</sup>	5,200	1. Power generator set with a common bed

### H. Hydrogen fuel tank

#### 1) Tank type and heat insulation system

Specifications of hydrogen storage tanks to be installed were considered based on the assumption that they would comply with the IGF Code. It was assumed that the tanks to be installed in the 20,000 TEU container ship, whose required capacity is expected to be large, would be the Type-B square tanks made of aluminum alloy while the ones to be installed in the 80,000 DWT bulk carrier would be the Type-C cylindrical tanks made of stainless steel.

The temperature of liquefied hydrogen is extremely low, requiring a high-performance heat insulation system. Therefore, vacuum heat insulation, which has been adopted in onshore tanks and the world's first liquefied hydrogen carrier, was adopted. The internal tank will be reinforced with a multilayer heat insulation material.

In principle, each tank will have a double structure, and the space between the external and internal tanks will be filled with vacuum for heat insulation. The external tank will serve as the partial secondary



barrier required for the Type-B tanks. The amount of boil-off gas was estimated based on the actual amounts of liquefied hydrogen carriers. Based on the tank capacities described below, the amount of evaporation of hydrogen per day (boil-off rate; BOR) is 0.39%/day for the 80,000 DWT bulk carrier and 0.27%/day for the 20,000 TEU container ship. Details of the tank structure need to be further studied assuming issues, such as problems caused by the large size of the tank.

The maximum allowable relief valve setting (MARVS) was set at 0.07 MPa for the Type-B tank, following the IGF Code. Additional equipment will be needed to maintain the pressure within the range of the design pressure. The MARVS of the Type-C tank was set at 0.2 MPa based on the above BOR, reflecting 6.9.1 of the IGF Code, which says that the pressure shall be maintained below the set pressure of the tank pressure relief valves for a period of 15 days.

## 2) Capacity of hydrogen fuel tanks

The fuel tank capacity required for each ship was considered based on the cruising distance set in section F above and the fuel consumption rate of the main engine set in the section G above. The loading limit was calculated by applying the following formula, which is shown in 6.8.1-1 of the IGC Code.

$$LL = FL \frac{\rho_R}{\rho_L}$$

$LL$  stands for loading limit while  $FL$  is filling limit, which is stipulated as 98% under the code.  $\rho_R$  is the relative density of fuel (here, hydrogen) at the reference temperature while  $\rho_L$  stands for that at the loading temperature. A higher loading limit than calculated may be allowed, but it must never exceed 95%, according to the code.

Here, the Type-B tank will be filled under the atmospheric pressure ( $\rho_L = \rho_R$ ), resulting in  $LL = 95%$  under the above requirement.

The  $\rho_L$  of the Type-C tank was set at 0.071, which is the relative density of hydrogen at the atmospheric pressure. The relative density of hydrogen at the reference temperature, -250 degrees Celsius as saturation temperature, is  $\rho_R = 0.068$  at the above-mentioned MARVS of 0.2 MPa, resulting in  $LL = 94%$ .

Based on the above, the required tank capacity of each ship was set as follows.

- 80,000 DWT bulk carrier: 4,000 m<sup>3</sup>
- 20,000 TEU container ship: 30,000 m<sup>3</sup> (15,000 m<sup>3</sup> x 2)

## 3) Tank positioning

The hydrogen fuel tank for the 80,000 DWT bulk carrier was positioned on the stern deck (above the mooring equipment) because it would interfere with cargo hold opening and cargo handling if it were placed on the cargo hold deck, and because a dead space would be created on the deck if it were allocated under the deck. Crew accommodations were placed in the bow due to the required size of the fuel tank, which also reduced cargo hold capacity. As it was difficult to extend the total length of the ship

due to port restrictions (Port Kamsar is assumed), depth was increased to maintain cargo hold capacity.

The hydrogen fuel tank for the 20,000 TEU ship was positioned in the hold space, including the space under the crew accommodations under the deck, because cargo handling was assumed to be undertaken above the ship. Another reason for this placement is to make effective use of the space under the accommodation space, where containers cannot be loaded.

### I. Hydrogen fuel supply system

Figure Appendix 3.1-3 shows the outline of the fuel supply system. As a basic policy, the equipment configuration was assumed to be the same as that of the fuel supply system of LNG-fueled ships. This system sends hydrogen fuel from the liquefied hydrogen tank by generating higher pressure using a pump, and supplies vaporized hydrogen fuel gas to the buffer tank through the vaporizer and heat exchanger. The boil-off gas has its pressure increased by the compressor and is sent to the buffer tank through the heat exchanger. Hydrogen fuel gas is supplied to each piece of equipment from the buffer tank.

Duplex vacuum pipes are used for extremely low temperature sections to transfer hydrogen fuel. Fuel pipes in safety compartments, such as the engine room, are placed inside ducts. Equipment and pipes compatible with the extremely low temperature, high permeability, and other unique properties of hydrogen need to be selected.

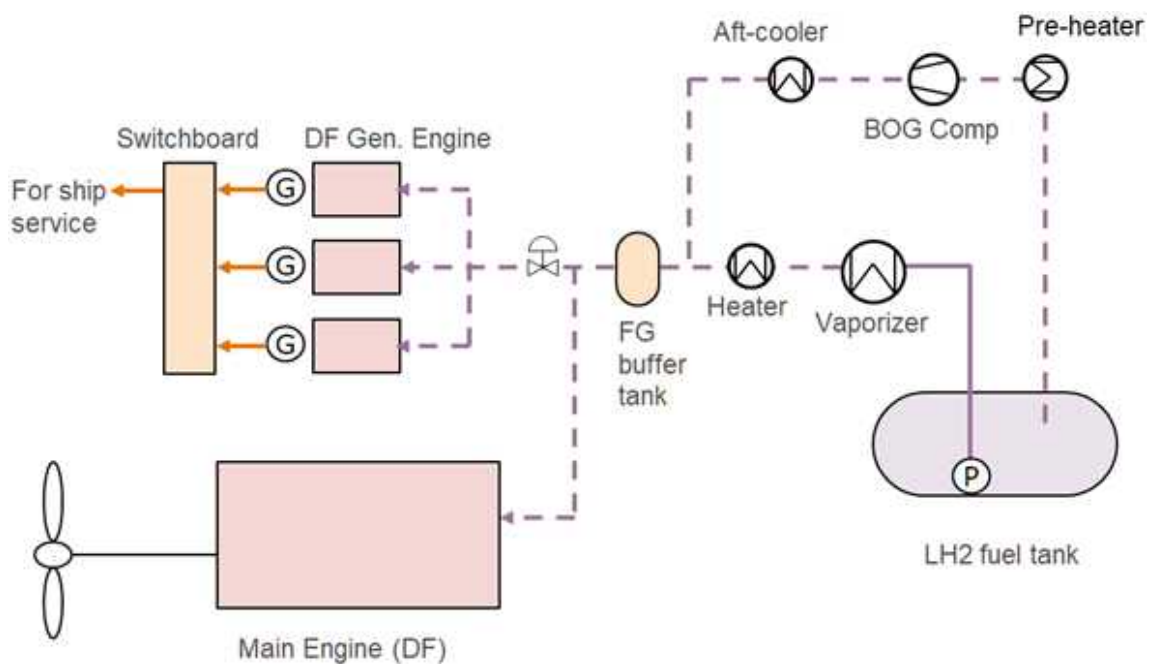

Figure Appendix 3.1-3: The fuel supply system

## (2) Concept Ship Specifications

### A. Specifications of the 80,000 DWT bulk carrier

Appendix 3.1-4 shows the general arrangement of the 80,000 DWT bulk carrier. The principal characteristics are as shown in Table Appendix 3.1-3. The bird's eye view is shown in Figure Appendix

3.1-5 while the configuration of hydrogen fuel equipment is shown in Figure Appendix 3.1-6.

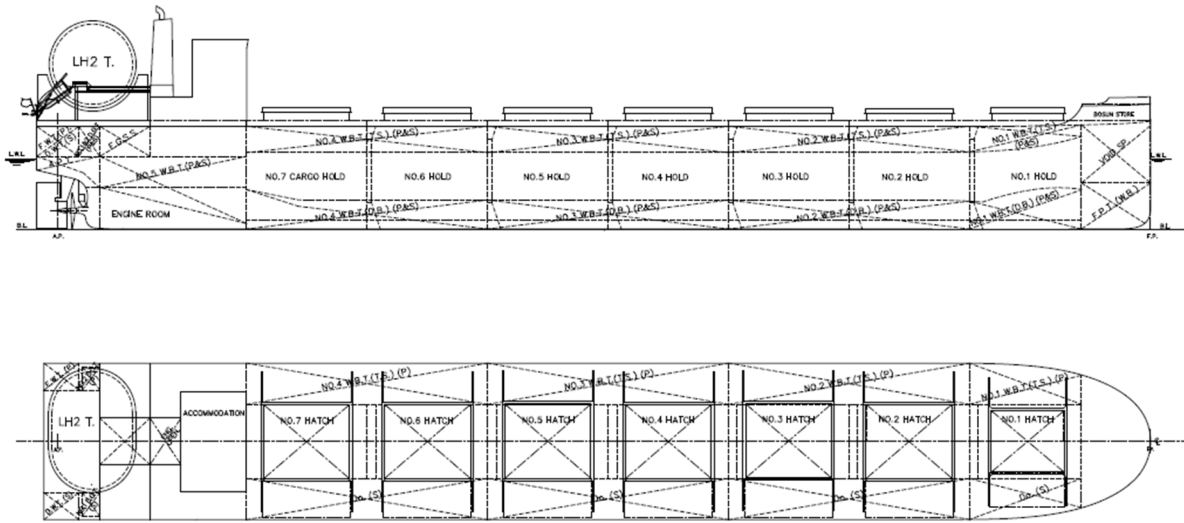

Figure Appendix. 3.1-4: General Arrangement of the Hydrogen-fueled 80,000 DWT Bulk Carrier

Table Appendix 3.1-3: Principal Characteristics of the Hydrogen-Fueled 80,000 DWT Bulk Carrier

Total length	228.9 m
Ship length	226.00 m
Total width	32.24 m
Depth	21.20 m
Draft	
Designed draft	12.20 m
Full load summer draft	14.50 m
Deadweight	
Designed draft	63,500 tons
Full load summer draft	80,000 tons
Cargo hold	97,000 m <sup>3</sup>
Liquefied hydrogen tank	4,000 m <sup>3</sup>
Designed speed	14.0 knots
Cruising distance	7,000 nm
Main engine	1 unit
Maximum output	8,000 kW x 84 rpm
Normal output	6,800 kW x 80 rpm
Power generator	3 units
	1,000 kW



Figure Appendix 3.1-5: Bird's Eye View of the Hydrogen-fueled 80,000 DWT Bulk Carrier

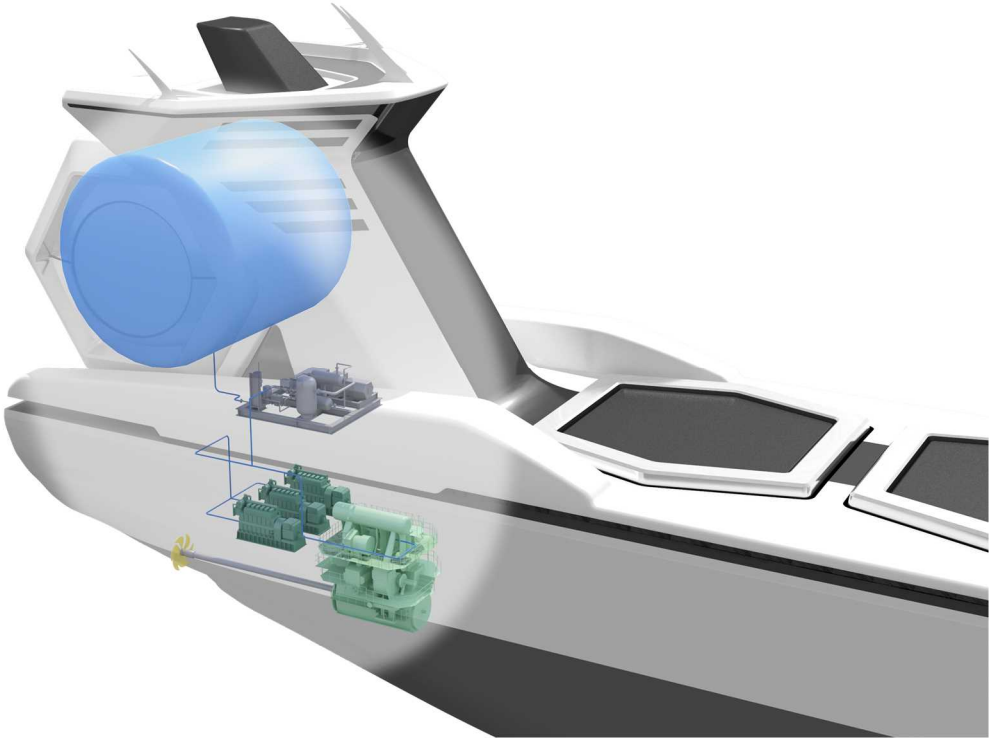

Figure Appendix 3.1-6: Configuration of Hydrogen Fuel System of the 80,000 DWT Bulk Carrier

B. Specifications of the 20,000 TEU container ship

Figure Appendix 3.1-7 shows the general arrangement of the 20,000 TEU container ship. The principal characteristics are as shown in Table Appendix 3.1-4. The bird's eye view of the ship in 2050 is shown in Figure Appendix 3.1-8 while the configuration of hydrogen fuel equipment is shown in Figure Appendix 3.1-9.

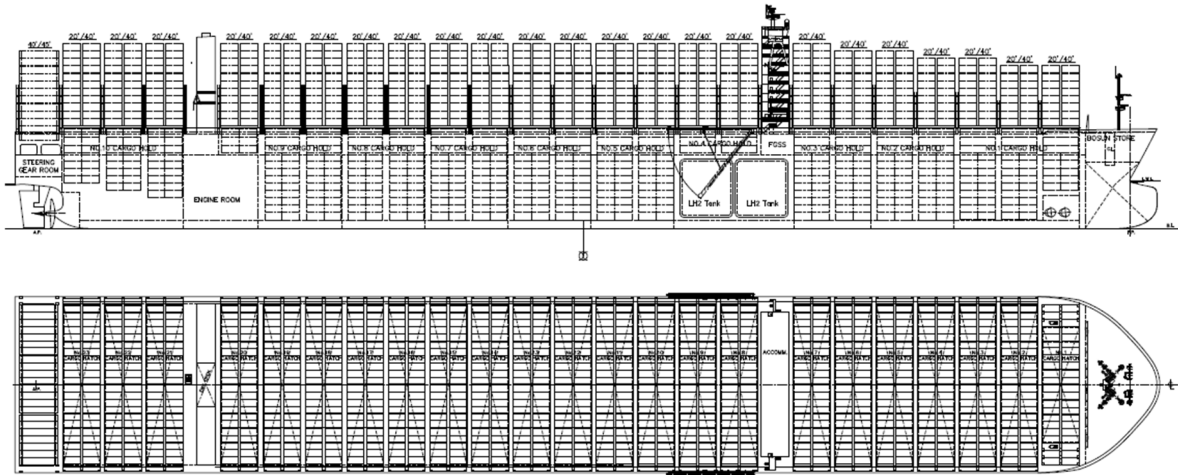

Figure Appendix 3.1-7: General Arrangement of the Hydrogen-fueled 20,000 TEU Container Ship

Table Appendix 3.1-4: Principal Characteristics of the Hydrogen-fueled 20,000 TEU Container Ship

Total length	399.90 m
Ship length	383.00 m
Total width	61.50 m
Depth	33.00 m
Draft	
Designed draft	14.50 m
Full load summer draft	16.50 m
Deadweight	
Designed draft	184,000 tons
Full load summer draft	228,000 tons
Liquefied hydrogen tank	30,000 m <sup>3</sup>
Number of containers	21,000 TEU
Freezing container plugs	1,100 TEU
Designed speed	22.5 knots
Cruising distance	11,500 NM
Main engine	1 unit
Maximum output	60,000 kW x 80 rpm
Normal output	54,000 kW x 77 rpm
Power generator	3 units
	5,000 kW





Figure Appendix 3.1-8: Bird's Eye View of the Hydrogen-fueled 20,000 TEU Container Ship

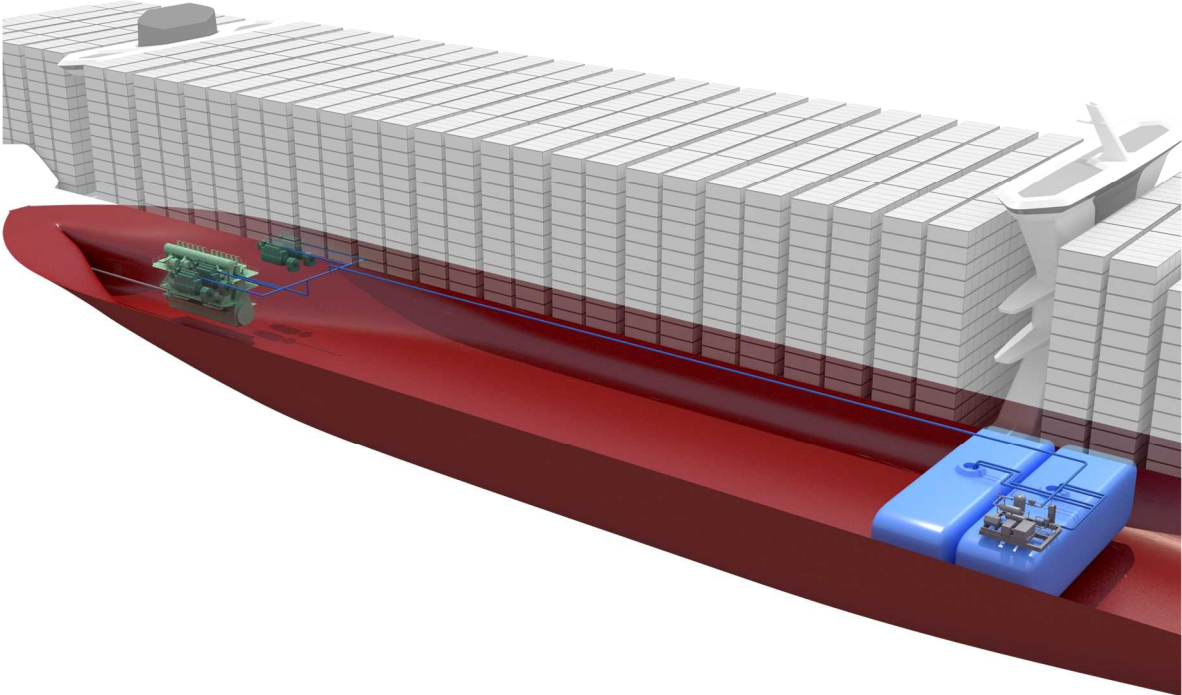

Figure Appendix 3.1-9: Configuration of Hydrogen Fuel System of the 20,000 TEU Container Ship

### **(3) Technological Issues to be Addressed for Practical Use of the Hydrogen-fueled Ships**

#### **A. Larger tanks**

Regarding the cylindrical tank, the 1250 m<sup>3</sup> tank of the existing liquefied hydrogen carrier already has the maximum thickness at the suction well, dome parts, and their surroundings in consideration of the manufacturing and processability of the tank. A larger tank generates greater stress at the above points, which makes the required thickness exceed realistic levels. In addition, a larger tank would also mean a larger diameter of the external tank. This makes it difficult to achieve the required external tank buckling strength against the negative pressure of the vacuum between the internal and external tanks.

Regarding the square tank, there is significant distortion from welding if the tank is made of an aluminum alloy. Accordingly, accuracy control and the quality control of welded parts (manually welded parts in particular) are important.

In addition, an appropriate supporting method connecting the internal and external tanks and a mechanism for absorbing the relative displacement between them needs to be developed.

#### **B. Heat insulation system**

Vacuum heat insulation is used in the fuel tanks and transport pipes. Vacuum is depleted by the emissions of adsorbed gases and occluded gases specific to the metals, as well as gases transmitted through O-rings and gaskets. Therefore, a technology for preventing or minimizing vacuum depletion is necessary. In addition, if the foam heat insulation used on LNG-fueled ships is adopted instead of vacuum insulation, the foaming gas may become solidified at the extremely low temperature and be unable to demonstrate expected heat insulation performance, so a new heat insulation system needs to be developed.

#### **C. Hydrogen leakage**

Hydrogen is likely to leak from the joints of flanges and other parts because of its small molecular mass. Therefore, measures need to be devised to prevent hydrogen leakage. In addition, it is necessary to design a ventilation system capable of discharging the hydrogen gas leaked into the enclosed spaces (including the engine room) to the open spaces without allowing concentrations to reach a dangerous level. Appropriate structures for the enclosed spaces and the protection of hydrogen gas fuel pipes are also necessary. Further, it is necessary to ensure appropriate designs for the hydrogen gas atmosphere (within the range where an explosive reaction occurs, including in case of the leakage), such as the complete prevention of sparks and static electricity and the use of equipment meeting an appropriate explosion class for hydrogen.

#### **D. Hydrogen refueling**

Heating value per volume of hydrogen is lower than that of heavy oil and natural gas, so the frequency of refueling is expected to be higher than those for the other fuels. Accordingly, it is necessary to prepare

many bunkering bases and hydrogen bunker ships. It is also necessary to consider bunkering methods which are appropriate for preventing the loss of fuel caused by evaporation during the re-filling.

#### E. Hydrogen fuel supply system

Because of hydrogen's physical properties, notably its extremely low boiling point and low specific gravity, differ from those of LNG / LPG, it is necessary to ensure a structure and control which are appropriate for the required pressure, temperature, and load fluctuation of a hydrogen-powered engine. It is also necessary to select devices for detecting and shutting off hydrogen leakages and for preventing and detecting fires in enclosed spaces, including the engine room, and to consider where to install those devices.

#### F. Hydrogen-fueled engine

Where hydrogen gas is burned through flame propagation (premixed combustion), abnormal combustion is likely to occur, resulting in increased NO<sub>x</sub> emissions, due to the high burning velocity of hydrogen gas. It is therefore necessary to control the burning velocity of hydrogen gas. To put the engine to practical use, it is necessary to keep in mind that further technological evaluation is necessary to determine whether lean premixed combustion (Otto cycle) or direct injected diffusion combustion (diesel cycle) is optimal.

It is difficult to seal fuel valves to prevent the leakage of hydrogen fuel, because hydrogen molecules are small and therefore likely to leak via tiny clearance of the valve. Further, those valves are prone to attrition because of their low lubricity. Accordingly, a fuel valve with sufficient durability and reliability needs to be developed. In addition, hydrogen gas has a wide flammable range and small minimum ignition energy. This carries with it the risk of combustion of unburned hydrogen gas flown into an exhaust pipe due to an accidental fire.



## 2. Ammonia-fueled Ships

### (1) Concept Design

#### A. Overview

A concept for an 80,000 DWT ammonia-fueled bulk carrier was designed, and relevant technical issues were identified.

#### B. Ammonia fuel

As Figure Appendix 3.2-1 shows, GHG zero-emission can be achieved, even when the lifecycle emissions are assessed and considered, by using ammonia fuel which is produced from hydrogen and nitrogen using renewable energy. Accordingly, an ammonia-fueled ship was selected as one of the project's zero-emission ships. In developing the concept design, the following issues were identified:

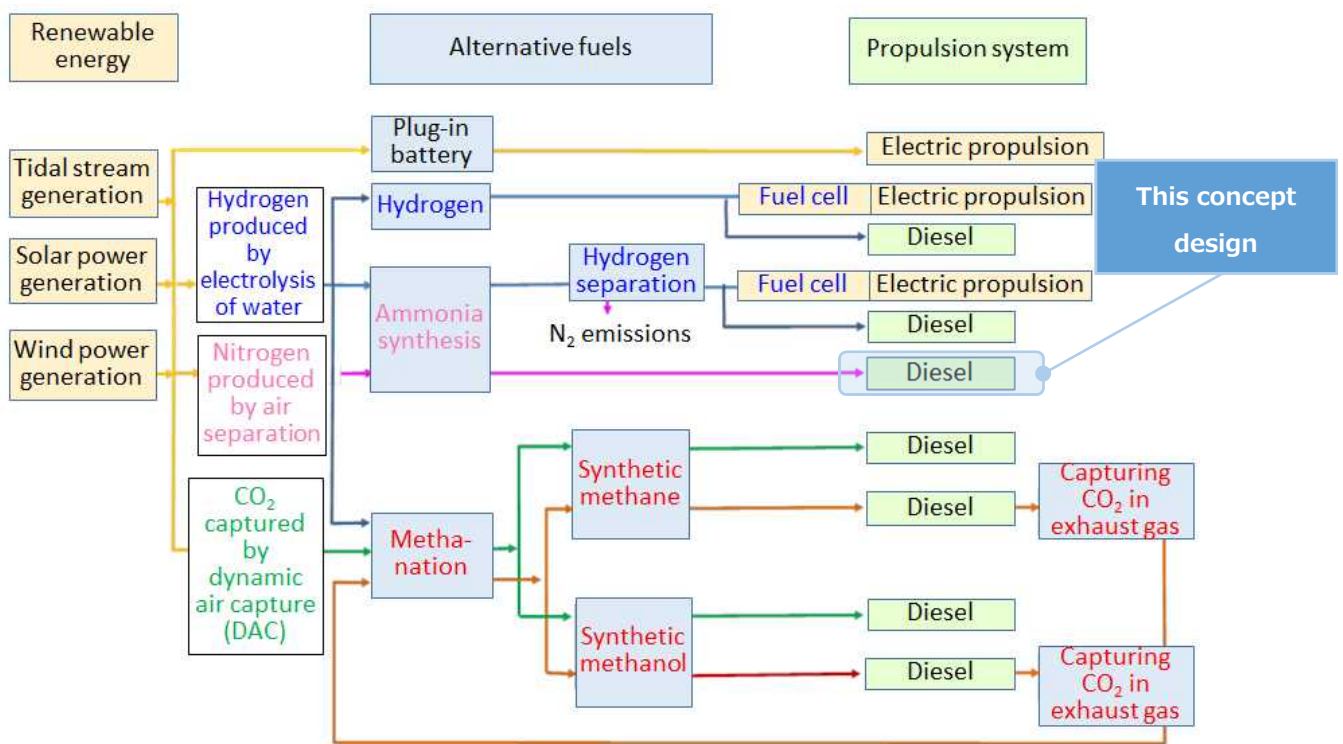
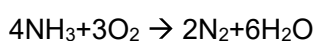

Figure Appendix 3.2-1: Chart of Alternative Fuel Production

#### 1) Combustibility

The general reaction formula for the combustion of ammonia is as follows.



The flammable range of ammonia in terms of ratio to the air is 15% to 25% by volume. In addition, its laminar burning velocity is only around 20% of that of methane. It can therefore be said that ammonia is a fire-retardant fuel. As a diesel fuel, ammonia does not self-ignite easily and has an octane rating of

130, and its ignition temperature is 650 °C, higher than that of existing diesel fuels. In addition, the fuel contains nitrogen atoms, which means that there is the possibility of NO<sub>x</sub> being generated during the combustion of ammonia. On the other hand, as ammonia does not contain carbon, it will not generate soot nor black carbon.

## 2) Toxicity

Ammonia is an alkaline, colorless gas, which is corrosive and has an extremely strong, irritating odor. It is highly irritating to the mucosa, and the inhalation of a highly concentrated ammonia gas may seriously damage the respiratory tract and the lungs in a short time. The Threshold Limit Value – Time Weighted Average (TVL-TWL) is set at 25 ppm.

## 3) Storage performance

The lower heating value of ammonia is 18.8MJ/kg, which is around 44% of that of heavy oil (42.7MJ/kg). Ammonia requires a tank capacity about 2.7 times larger than that of the existing HFO tank. Ammonia requires a tank 1.7 times larger than LNG fuel and 2.0 times larger than LPG fuel. Ammonia's storage requirements are close to the fuel tank requirements of LPG-powered ships, so LPG storage tanks may be used for ammonia-fueled ships.

## 4) Corrosiveness

Ammonia is corrosive to copper, copper alloys, alloys whose nickel concentration exceeds 6%, and plastics. Accordingly, use of these materials needs to be avoided. In addition, Teflon is a preferred sealing material.

## C. Ship type, hull form, and route

Ship types and ship size selected for consideration in the concept design need to fulfill the following conditions. First, they are used in international shipping, which will keep playing a major role in international logistics, and therefore are to be built in large numbers. Second, they are highly likely to call at ports all over the world, including potential bunkering points in Europe, the Middle East, Australia, Japan, and South America (such as Chile). In light of these, 80,000 DWT bulk carriers, fulfilling these conditions and being able to pass through the Panama Canal, was selected for this concept design. This concept ship is assumed to travel the route between Japan and Australia.

## D. Ammonia fuel tank

The heating value of ammonia fuel is low (approx. 44% of that of heavy oil). In addition, an ammonia fuel tank needs to be an independent tank with a heat insulating structure. Therefore, its capacity needs to be two to three times larger than the existing HFO tanks. For this concept design, a cylindrical horizontal IMO Type C tank was selected.

The upper deck area of the bulk carrier that was the focus of this concept design is occupied mostly by hatch covers and their range of motion. Therefore, space for the fuel tank is limited unless the cargo hold area is redesigned significantly. In this concept design, the fuel tank was positioned on the stern side of the accommodation space. The fuel tank capacity and cruising distance were set in consideration

of the space necessary for the installation of fuel handling equipment, deck machinery, funnel, and other equipment.

#### E. Engine using ammonia fuel

The main engine assumed herein is a dual fuel engine with an MCR of 9,660 kW x 89.0 rpm. It complies with the IMO NO<sub>x</sub> Tier III regulations and has a liquid fuel injection mechanism, which has currently been used for methanol, LPG, and other fuels. Because ammonia fuel is fire-retardant, the injection of a pilot fuel is necessary to control ignition. The engine assumed for this concept design is one including a pilot fuel injection valve and has a capability of maintaining its output using an oil fuel only, as shown in Figure Appendix 3.2-2 and Figure Appendix 3.2-3.

To achieve practical application, it needs to be kept in mind that the stability of ammonia combustion, ammonia slip, generation of N<sub>2</sub>O, and other phenomena need to be understood, and (where necessary) methods for tackling them need to be established.

The fuel system has a double-pipe structure complying with the IGF Code. In the event of an abnormality in the gas fuel system, its control function automatically stops the supply of gas and continues operation with oil fuel only, which is used for the pilot fuel. In the future, absolutely zero emissions can be achieved by using a zero GHG emission pilot fuel, for example, a biofuel. For this concept design, MGO was selected as the pilot fuel.

#### 1) Diagram of the engine system

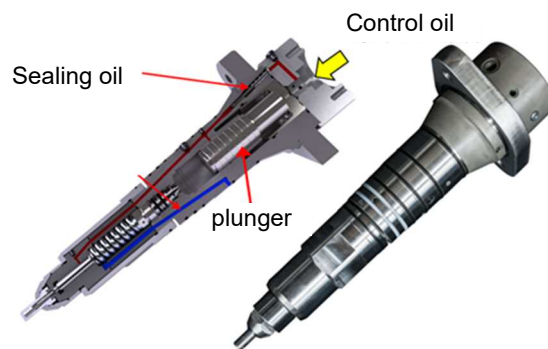
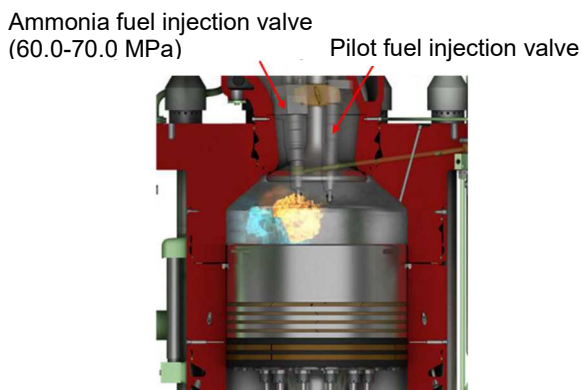
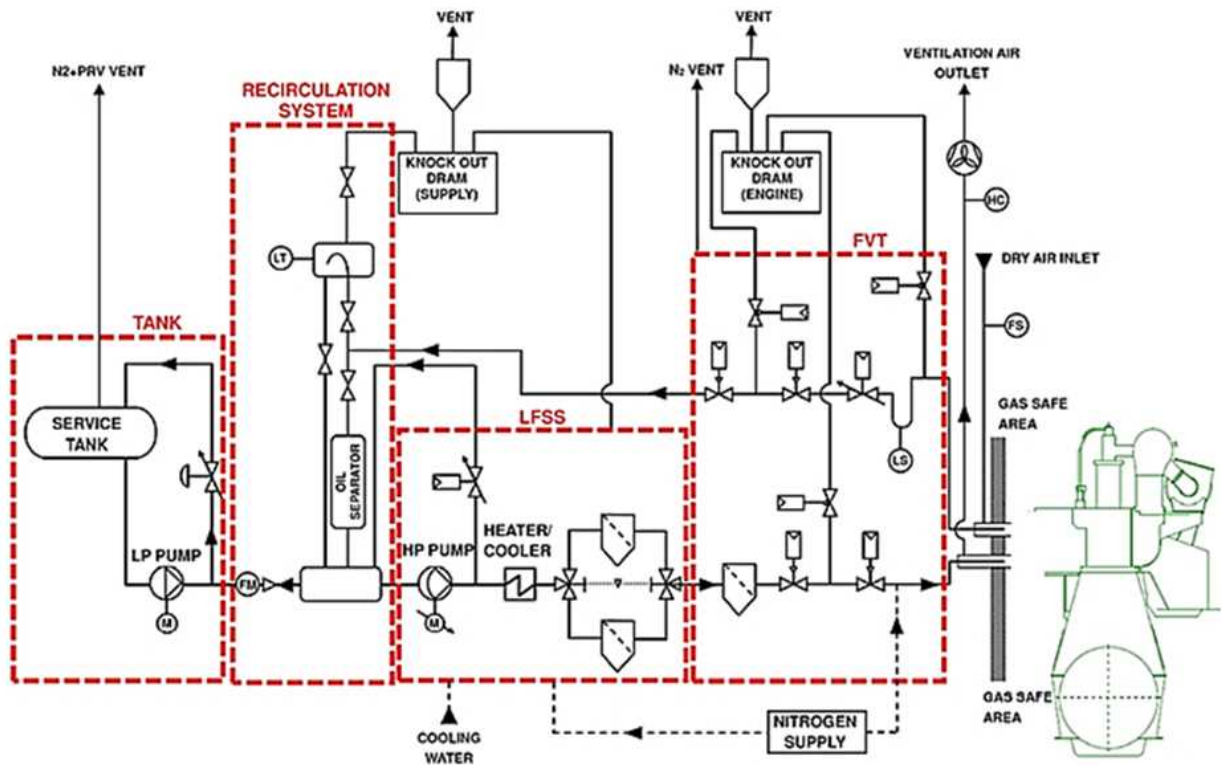

Figure Appendix 3.2-2: Ammonia-powered Engine Figure Appendix 3.2-3: Ammonia Fuel Injection Valve (Fuel Booster Injection Valve, FBIV)

Figure Appendix 3.2-4 is a diagram of the engine system chosen for this concept design. It is based on an existing engine, and a space for the installation of a device, which lowers the concentration of the ammonia, is secured after the knock-out drum and before the vent. An oil separator, which separates sealing oil from ammonia fuel, is set on the ammonia return line. The engine supply pressure of the ammonia was set at 7 MPa.



Appendix 3.2-4: Fuel System of the Ammonia-powered Engine

## 2) Compliance to NO<sub>x</sub> Tier III

Exhaust gas reduction (EGR) or selective catalytic reactor (SCR) technology can be applied to reduce NO<sub>x</sub> emissions. This concept design selected SCR because by employing SCR using ammonia, instead of urea, as a reductant agent, a separate tank for the agent is not necessary. It should be noted that, at the same time, additional safety measures in accordance with the IGF Code, such as the adoption of a double-pipe structure in the engine room, are needed.

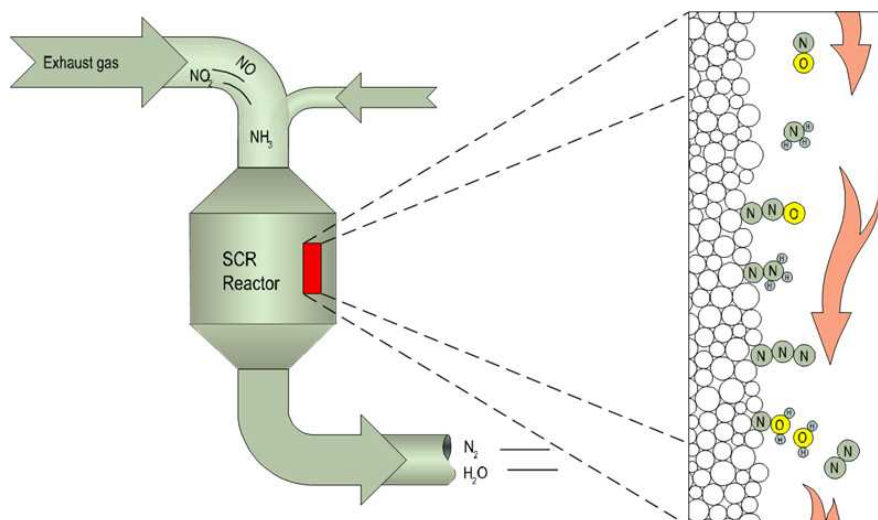

Figure Appendix 3.2-5: High-pressure SCR

The impact of ammonia fuel on NO<sub>x</sub> emissions is still unknown. However, if NO<sub>x</sub> emissions exceed the Tier II limit by 30%, being 18.7g/kWh, the necessary amount of ammonia to comply with the Tier III limit will be around 5.6g/kWh, which is equivalent to merely 1.6% of fuel consumption (approx. 350g/kWh). Therefore, the amount of use of ammonia needed for the SCR is small compared to the fuel consumption of the main engine.

## (2) Concept Ship Specifications

### A. Principal characteristics

Table Appendix 3.2-1 lists the principal characteristics of the 80,000 DWT bulk carrier concept design.

Table Appendix 3.2-1: Principal Characteristics of Ammonia-fueled 80,000 DWT Bulk Carrier

<b>81,000 DWT Ocean-going Bulk Carrier</b>	
Major dimensions [m]	Loa / Lpp / Bm / D / ds / dd: 233 / 225.5 / 32.26 / 20.10 / 14.45 / 12.20
Loading capacity	81,000 DWT
Design speed	14.2 kn (@NOR/15%SM)
Route	Japan-Australia
Propulsion engine	Low-speed Dual-Fuel (Ammonia) diesel engine (future commercialization is assumed) MAN B&W 6S60ME-C8.5-LGI(A)-HPSCR: MCR 9,660 kw, NOR 7,052kw
Generator	Medium-speed Dual-Fuel (Ammonia)diesel engine (future commercialization is assumed) 600kW × 3 sets
Ammonia tank	IMO Type-C horizontal cylindrical tank (400 kpaG × -33.3°C, steels for low temperature service) Capacity: 1,550 m <sup>3</sup> (for one-way trip between Japan and Australia)
CO <sub>2</sub> reduction	- 91.9% (Use of MGO pilot fuel is considered.)
Impact on capacity	approx. - 0.7% DWT

Regarding its major dimensions, the ship's hull was extended approx. 4 meters longer than the typical existing 80,000 DWT bulk carriers aft of crew accommodations, to secure space for the ammonia fuel tank and other equipment.

For cruising distance and ammonia tank capacity, two cases -- one-way trip and round trip -- were considered. The results are shown in Table Appendix 3.2-2. The impact of the extended ship hull and the ammonia tank capacity were assessed as changes to its deadweight. The impact of each case is equivalent to -0.7% DWT for one-way trips and -1.2% DWT for round trips.

In this concept design, the ammonia-fueled ship is estimated to reduce 91.9% of CO<sub>2</sub> emissions

compared to conventional 80,000 DWT bulk carriers. It assumed that an auxiliary engine would be powered by ammonia fuel, while MGO would be adopted as the pilot fuel of both the main engine and the auxiliary engine.

#### B. General arrangement and bird's eye views

Bird's eye views of the concept design ship are shown in Figure Appendix 3.2-6 and Figure Appendix 3.2-7.

To install the ammonia tank, aft of the crew accommodations, the funnel and engine casing are offset to the starboard side. The ammonia tank is installed in the space from the center of the hull to the portside. Under the deck where the tank is installed, a machine room for handling ammonia is installed. The bunkering manifold for the ammonia fuel is installed on both sides of the stern together with a hose handling crane. The general arrangement of the ship is shown in Figure Appendix 3.2-8.



Figure Appendix 3.2-6: Bird's Eye View of the Ammonia-fueled 80,000 DWT Bulk Carrier (1)





Figure Appendix 3.2-7: Bird's Eye View of the Ammonia-fueled 80,000 DWT Bulk Carrier (2)

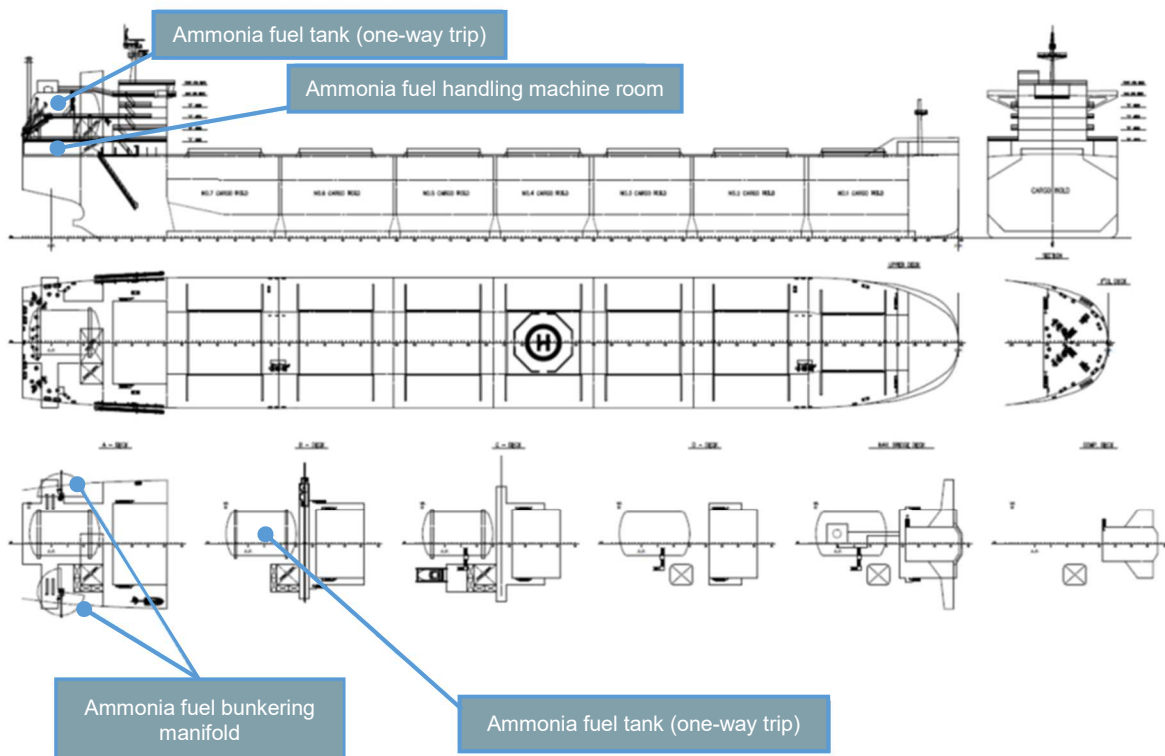
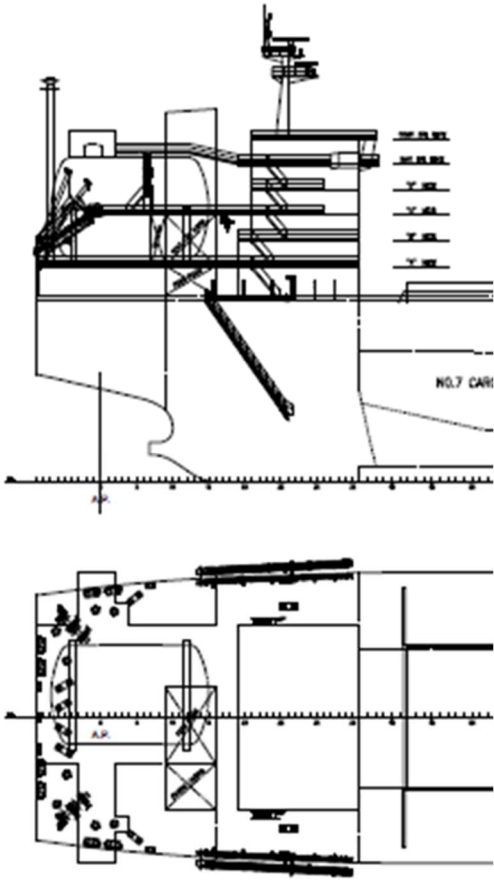
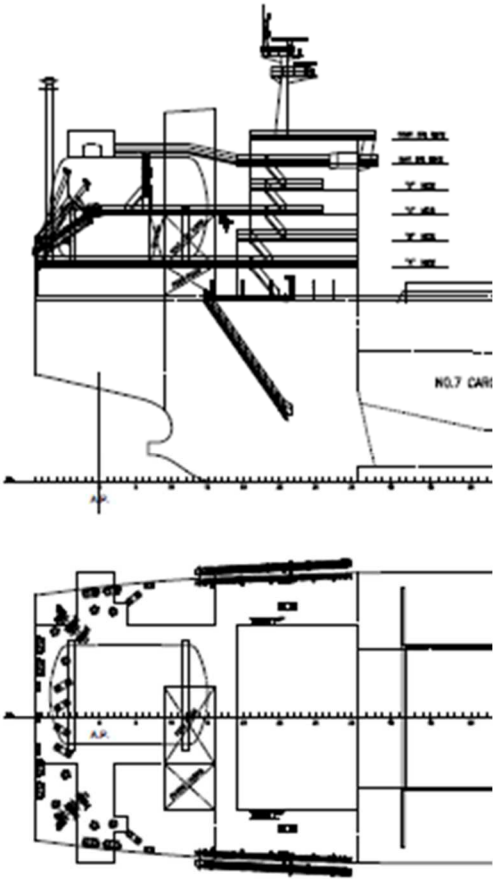

Figure Appendix 3.2-8: General Arrangement of the Ammonia-fueled 80,000 DWT Bulk Carrier

Table Appendix 3.2-2: Comparison of the Impact of Fuel Tank Capacity on DWT of the Ammonia-fueled 80,000 DWT Bulk Carrier

<p>Tank arrangement</p>		
<p>Ammonia fuel tank</p>	<p>Japan to Australia (for one-way trip): 1,550 m<sup>3</sup></p>	<p>Japan to Australia (for round trip): 3,100 m<sup>3</sup></p>
<p>Impact on the deadweight</p>	<p>-0.7% DWT</p>	<p>-1.2% DWT</p>

### (3) Technological Issues to be Addressed for Practical Use of Ammonia-fueled Ship

#### A. Risk assessment

The engine of this concept ship is assumed to fulfill the requirements of the IGF Code. However, risks need to be identified through a risk assessment (HAZID/ HAZOP) in consideration of the conditions specific to ammonia fuel, such as the health hazards related to the toxicity of ammonia fuel.

#### B. Guidance related to the emission of ammonia to the atmosphere in an emergency

As ammonia turns into a gas under atmospheric pressure, it may spread widely in a short time in case of leakage. In such a case in ports and similar facilities, there are likely to be health hazards to people outside the ships. Therefore, measures to prevent the leakage from equipment on the deck and other measures, including the external release of the air from the external pipe of the double pipe, may be



needed in addition to those taken in case of existing gas-fueled ships.

#### C. Ammonia release which occurs when ammonia combustion stops

The engine of the concept ship is assumed to replace the gas fuel in the pipes inside the engine room with nitrogen when gas combustion is stopped, to keep the inside of the engine room gas-free. In case where ammonia fuel is used as the gas fuel, the ammonia released in the above transition should be minimized. Possible methods of minimizing the amount of the released ammonia include the dilution of ammonia to 10 ppm or below, collecting the ammonia, or extending the vent pipe high enough to ensure safety.

#### D. Minimizing the risk of significant leakage ammonia

Ammonia normally turns into a gas under atmospheric conditions, and its specific gravity is lower than that of the air. Accordingly, ammonia would diffuse upward. However, ammonia's evaporative latent heat is high, so it is also assumed that, if a large amount of ammonia is leaked, it cools down the surrounding air, thereby inhibiting gasification and extending the time ammonia stays at a low level. This increases the risk of fire and suffocation. If the ammonia fuel supply pipe were damaged by an impact from outside or similar phenomena, a large amount of ammonia could leak, which is likely to increase unexpected risk factors. Accordingly, the risks of the leakage of large amount of ammonia need to be minimized by appropriate design of the piping route, protection of the equipment from mechanical damage, restriction on access to the pipes during gas-powered operation, and other measures.

#### E. Components of exhaust gases

As described above, the NO<sub>x</sub> emissions attributed to ammonia fuel have yet to be confirmed. Above all, research into nitrogen monoxide (N<sub>2</sub>O), a greenhouse gas, is needed as it has a large global warming potential. It is reported that the amount of nitrogen monoxide emissions into the atmosphere can be reduced by a catalyst or by controlling the air-fuel ratio. It is necessary to explore reduction measures including but not limited to aforementioned ones.

#### F. Design capacity of the pilot oil tank and redundancy of the gas fuel system

The engine selected for this concept ship can continue operating as an oil-powered engine in the event of a failure of the gas fuel system. Because the oil tank capacity is sufficient for cruising, redundancy is not provided in the gas fuel system. The significant downsizing of the oil tank and the doubling of the gas system capacity are among the issues to be considered in the future.

#### G. Protective equipment

Maintenance workers need to wear protective gear to prevent ammonia from directly contacting the eyes or skin. They also need to wear protective masks to prevent the inhalation of toxic gas. In addition, toxic gas may be generated during a fire of the engine room. Therefore, the position of exhaust vents and other related details need to be considered carefully.

#### H. Issues to be considered regarding ammonia-fueled auxiliary engine

It is necessary to develop an ammonia-fueled auxiliary engine, a large, high-efficiency shaft generator (as an alternative to the ammonia-fueled auxiliary engine), an ammonia fuel cell for supplying power to be consumed on the ship, or a boiler/ GCU powered by ammonia fuel.

#### I. Others

In addition to the above technological issues, environmental arrangements, including reviews of the related IMO regulations and guidelines (e.g., IGF Code and IGC Code), are necessary as described in Chapter 5.

### 3. Onboard CO<sub>2</sub> Capturing Ship

#### (1) Design concept

##### A. Overview

A 20,000 TEU container concept ship with an onboard CO<sub>2</sub> capturing system was designed, and issues were identified.

##### B. Methanol fuel

As described in section 4.3, one fuel which could achieve zero GHG emissions is carbon-recycled fuel (synthetic fuel produced from the captured CO<sub>2</sub> and hydrogen). Typical carbon-recycled fuels include synthetic methane and synthetic methanol. A chart showing the production process of these fuels is shown in Figure Appendix 3.3-1.

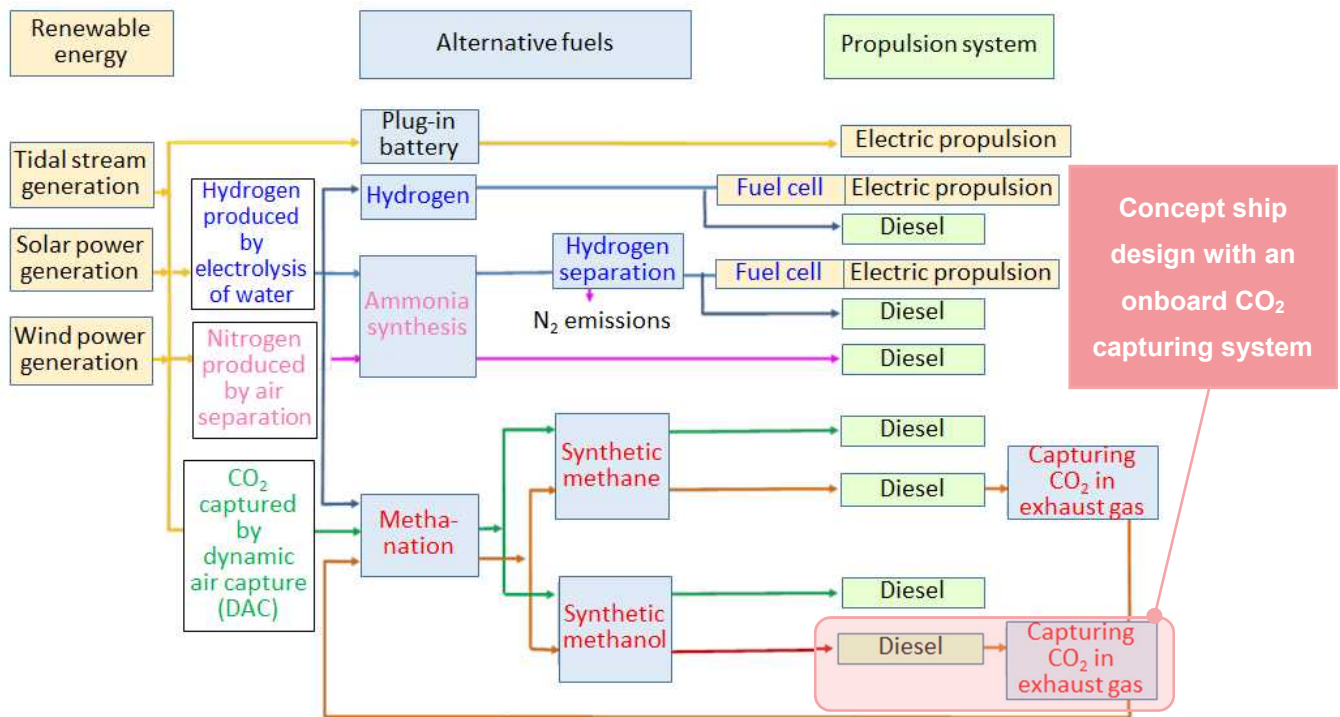

Figure Appendix 3.3-1: Alternative Fuel Production Diagram

##### C. Ship type, ship size, and route

Ship types and sizes selected for consideration for the concept design need to fulfill the following conditions. First, they are used in international shipping, which will keep playing a major role in international logistics, and are therefore to be built in large numbers. Second, they are highly likely to call at ports all over the world, including potential bunkering locations such as Europe, the Middle East, Australia, Japan, and South America (such as Chile). In light of these conditions, the 20,000 TEU container ship was selected to be the subject of this concept design. This concept ship is assumed to travel the route between the Far East and Europe.

#### D. Placement of fuel tanks and CO<sub>2</sub> capturing system

The heating value of methanol fuel is low (approx. 47% of that of heavy oil). In addition, the tank for captured CO<sub>2</sub> needs to be an independent tank with a heat insulating structure. Therefore, a part of the container hold needs to be converted into the space for this tank. For the concept design, the CO<sub>2</sub> capturing system is placed in the container space forward of the stern funnel while the CO<sub>2</sub> tank and methanol fuel tank are positioned under the crew accommodation area at the bow. Cruising distance was determined in consideration of fuel consumption, capacity of the captured CO<sub>2</sub> tank, and the tank's impact on container capacity.

#### E. Technology for capturing and liquefying CO<sub>2</sub> onboard

Figure Appendix 3.3-2 outlines the systems for capturing, liquefying, and storing CO<sub>2</sub> adopted for this concept design.

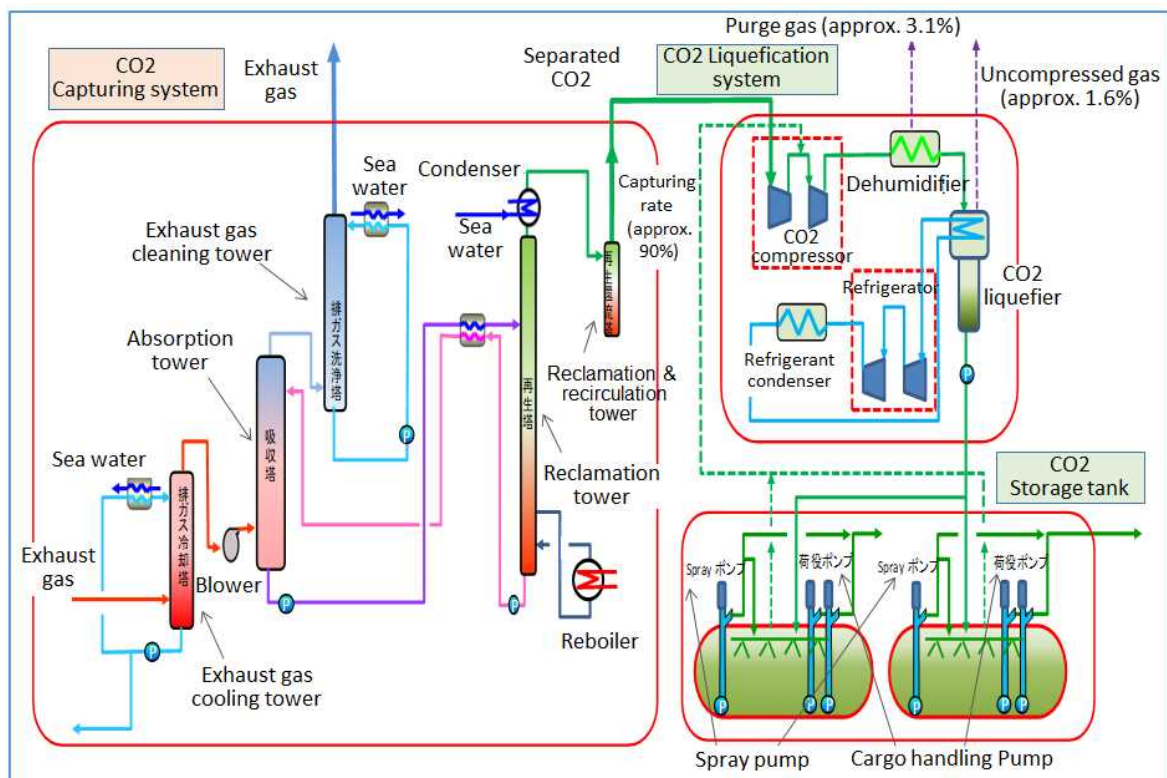

Figure Appendix 3.3-2: Systems for Capturing, Liquefying, and Storing CO<sub>2</sub>

##### 1) Liquid amine absorption method for CO<sub>2</sub> capturing

The technology for CO<sub>2</sub> capturing adopted in this concept design is amine absorption, which has been utilized in the CO<sub>2</sub> capturing systems for coal thermal power plants. In this method, the CO<sub>2</sub> contained in exhaust gas is selectively absorbed into a chemical-absorbing amine solution before being heated for separation. This absorption process is efficient for isolating CO<sub>2</sub> from large volumes of normal-pressure gas, with currently operated plants processing 200 to 5,000 tons/day.

This CO<sub>2</sub> capturing system consists of an exhaust gas cooling tower, a CO<sub>2</sub> absorption tower, an exhaust

gas cleaning tower, a CO<sub>2</sub> reclamation tower, a reclamation and recycling tower, and a reclamation reboiler.

The state of the CO<sub>2</sub> upon exiting the CO<sub>2</sub> capturing system is gas (water: 4.6 mol.%, saturated state) with temperature of 40 °C and a pressure of 0.6 kg/cm<sup>2</sup>G.

The isolation efficiency of the CO<sub>2</sub> capturing system is currently around 90%. However, further improvement of the isolation efficiency up to 95% has recently been considered with process simulations, which is expected to be achieved in the future.

## 2) System for liquefying and storing CO<sub>2</sub>

This system consists of a CO<sub>2</sub> compressor, dehumidifier, liquefier, refrigerator, liquefied CO<sub>2</sub> transfer pumps, and storage tanks (spray pumps and cargo handling pumps). The processes and equipment configuration of the liquefier and refrigerator were made as simple as possible in consideration of operability by crews. They were designed under the following conditions.

- Condition of the liquefied CO<sub>2</sub> exiting the liquefier:  
composition: 99.95% CO<sub>2</sub>, operating temperature: -46 °C, operating pressure: 715 kpaG
- CO<sub>2</sub> tank design conditions: temperature: -50 °C, pressure: 1.0 MPaG

As a result of calculation, the exhaust loss in the CO<sub>2</sub> process was as follows.

- Purge gas in dehumidifier: Approx. 3.1%, uncompressed gas in liquefier: Approx. 1.6%

## 3) Evaluation of different methods for CO<sub>2</sub> capturing (amine absorption and separation membrane processes)

### Amine absorption process

Figure Appendix 3.3-3 shows preferable CO<sub>2</sub> capturing methods (wet processes only), given i) the partial pressure of CO<sub>2</sub> in the exhaust gas supplied to the CO<sub>2</sub> capturing system as indicated on the vertical axis, and ii) the partial pressure of CO<sub>2</sub> in the gas exiting from the CO<sub>2</sub> capturing system as indicated in the horizontal axis. The vertical axis of this figure shows that the lower the partial pressure of CO<sub>2</sub> in the gas supplied to the system is, the lower the CO<sub>2</sub> concentration in the gas is. The horizontal axis shows that the lower the partial pressure of CO<sub>2</sub> in the gas exiting from the system is, the higher the CO<sub>2</sub> capturing rate grows.

The pressure of exhaust gas from ship engines is almost equal to atmospheric pressure, and its CO<sub>2</sub> concentration is approx. 5 vol%. Thus, the partial pressure of CO<sub>2</sub> in the gas is extremely low. The amine process is appropriate for capturing CO<sub>2</sub> at a high rate from a large volume of exhaust gas with low-partial-pressure CO<sub>2</sub>. Among the absorption methods using the amine process, KS-1TM has a high affinity for CO<sub>2</sub>. Therefore, KS-1TM is appropriate for capturing CO<sub>2</sub> from exhaust gases (low partial CO<sub>2</sub> pressure).

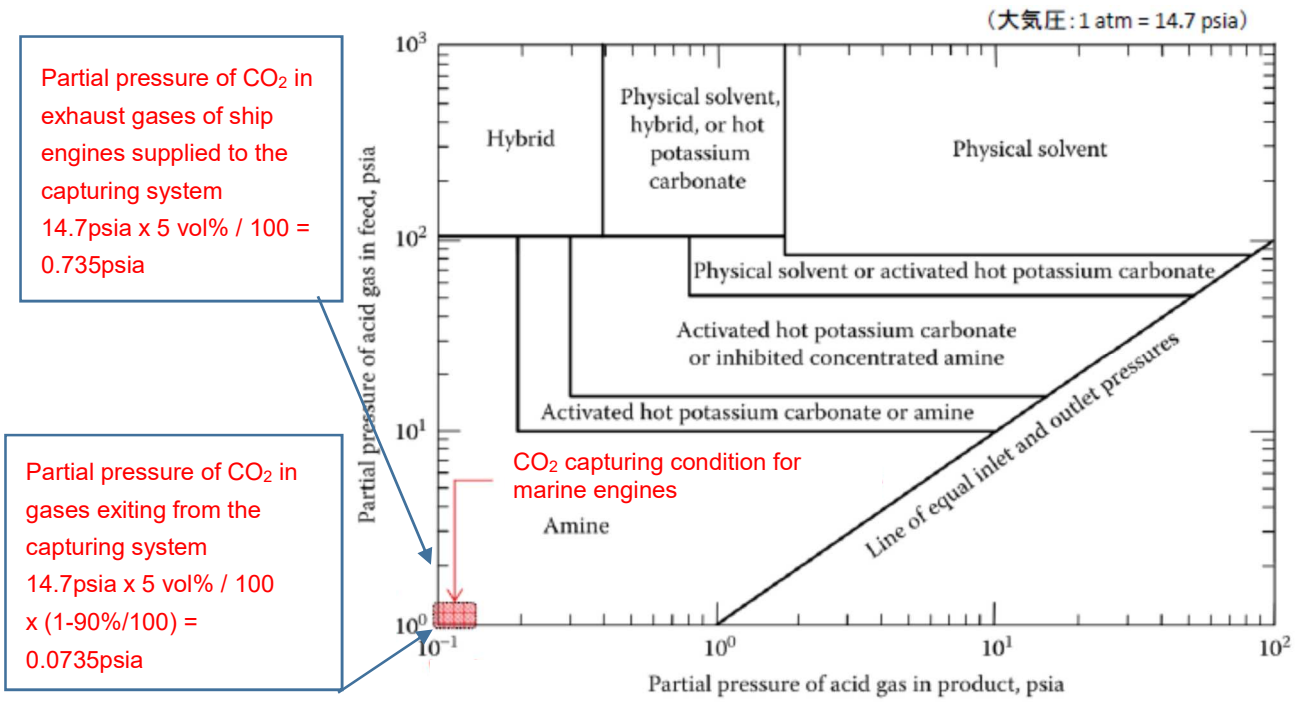

Figure Appendix 3.3-3: Selection of CO<sub>2</sub> Capturing Technology

### Separation membrane process

In the separation membrane process, a pressure difference is used as the driving force for the separation. Therefore, this method is appropriate for crude separation from high concentration gases (high partial pressure of CO<sub>2</sub>). This method is applied mainly in the onshore oil and gas sector. Accordingly, to apply the separation membrane process to exhaust gases of ships, whose pressure is close to atmospheric pressure, the CO<sub>2</sub> partial pressure on the permeation side needs to be further lowered so that CO<sub>2</sub> can permeate through the membrane, which requires the installation of a vacuum pump. In this process, a great amount of power would be necessary to reduce the pressure. Further, additional measures on the permeation side, such as steam purging, would be needed to achieve the CO<sub>2</sub> capturing rate and CO<sub>2</sub> purity close to those achieved by the amine process.

In the oil and gas sector, the combination of the membrane separation process and the amine absorption process is used to eliminate CO<sub>2</sub> to achieve a low concentration. The separation membrane is advantageous for reducing it down to roughly 10 vol% while the amine absorption process is advantageous for lowering the CO<sub>2</sub> concentration to 10 vol% or lower.

The separation membrane has an upper limit for the amount of gas permeated per unit area. Therefore, the amine absorption process has an advantage from the perspective of scaling up the process. The larger the amount of gas to be treated is, the wider the range where the amine absorption process is appropriate becomes, as shown in Figure Appendix 3.3-4.

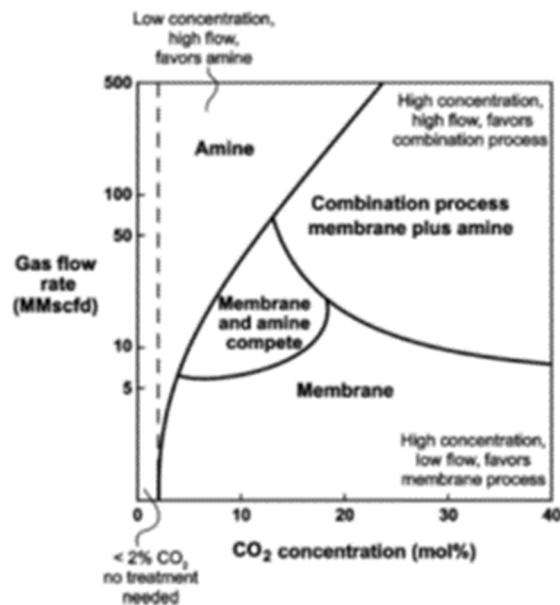

Figure Appendix 3.3-4: CO<sub>2</sub> Separation Capacity under High-pressure Conditions

## (2) Concept Ship Specifications

### A. Principal characteristics

Table Appendix 3.3-1 shows the principal characteristics of the 20,000 TEU container ship in this concept design.

Table Appendix 3.3-1: Principal Characteristics of the 20,000 TEU Container Ship

<b>21,000 TEU Ocean-going Methanol-fueled Container Ship</b>	
Major dimensions [m]	Loa / Lpp / Bm / D / ds / dd: 399.9 / 383.0 / 61.0 / 33.5 / 16.0 / 14.5
Loading capacity	21,300 TEU
Design speed	21.8kn (@NOR/15%SM)
Route	Far East - Europe
Propulsion engine	Low-speed Dual-Fuel (Methanol) diesel engine (future commercialization is assumed.) MAN B&W 11G90ME-LGI-C10.5-EcoEGR MCR 55,000 kw, NOR 49,500 kw
Generator	Medium-speed Dual-Fuel (Methanol) diesel engine 6,870 kw × 5 sets
Methanol tank	Tank integrated to the vessel's hull, Total capacity: 13,200 m <sup>3</sup> (for one-way trip between Far East and Europe) *Average operational load of existing ships (approx. 70%) is considered.
CO <sub>2</sub> emissions (supplied to carbon capturing system)	766 t/day @NOR (including additional CO <sub>2</sub> emissions by operating carbon capturing system)
CO <sub>2</sub> capturing rate of the carbon capturing system and Ship's CO <sub>2</sub> reduction rate	System's capturing rate: 85.7% / Ship's Reduction rate: 85% (Increased CO <sub>2</sub> emissions by additional energy consumption are considered.)
CO <sub>2</sub> tank	IMO Type C horizontal cylindrical tank, 6,400 m <sup>3</sup> × 2 sets (1.0 MPa × -50°C, steels for low temperature service)
Additional energy Consumption for operating the carbon capturing system	Additional energy consumption: +37.7% - CO <sub>2</sub> capturing system: Pump for absorbing solution, Exhaust gas blower, Pump for cooling sea water - CO <sub>2</sub> liquefier: CO <sub>2</sub> compressor, Refrigerator - CO <sub>2</sub> reclamation system: Reboiler using heating steam
Impact on capacity	Approx. -1,820 TEU



Regarding its major dimensions, the container hold was expanded one row longer than the conventional common 20,000 TEU container ship, in order to allow for i) the placement of the CO<sub>2</sub> capturing system in the container hold forward of the stern funnel and ii) the placement of the CO<sub>2</sub> tank and methanol fuel tank under the crew accommodation area at the bow, and to iii) maintain the container ship capacity no less than 20,000 TEU. The impact of the additional equipment related to the CO<sub>2</sub> capturing system on the capacity is equivalent to -1,820 TEU.

Regarding cruising distance and its impact on container capacity, one-way and round-trip scenarios were considered, as shown in Table Appendix 3.3-2. The impact on container capacity is equivalent to -1,820 TEU for a one-way trip and -2,550 TEU for a round trip.

In the concept design, the CO<sub>2</sub> capturing rate of the overall systems is 85.7% when loss during liquefaction is considered. The ship's CO<sub>2</sub> reduction rate is 80.3% when the additional energy for operating the systems (an additional 37% of the energy consumption of the main engine) is taken into account. However, further improvement of the CO<sub>2</sub> isolation efficiency up to 95% has recently been considered with process simulations, which is expected to be achieved in the future. Consequently, it is also expected that a CO<sub>2</sub> capturing rate of the overall system of 90% and a ship CO<sub>2</sub> reduction rate of 85% will be achieved in the future. These estimates were made based on the assumption that a auxiliary engine and auxiliary boiler powered by methanol fuel have been developed.

#### B. General arrangement and bird's eye view

Bird's eye views of the concept design are shown in Figure Appendix 3.3-5, Figure Appendix 3.3-6, and Figure Appendix 3.3-7. The general arrangement of the ship is shown in Figure Appendix 3.3-8 and Figure Appendix 3.3-9.



Figure Appendix 3.3-5: Bird's Eye View of the 20,000 TEU Container Ship with an Onboard CO<sub>2</sub> Capturing System

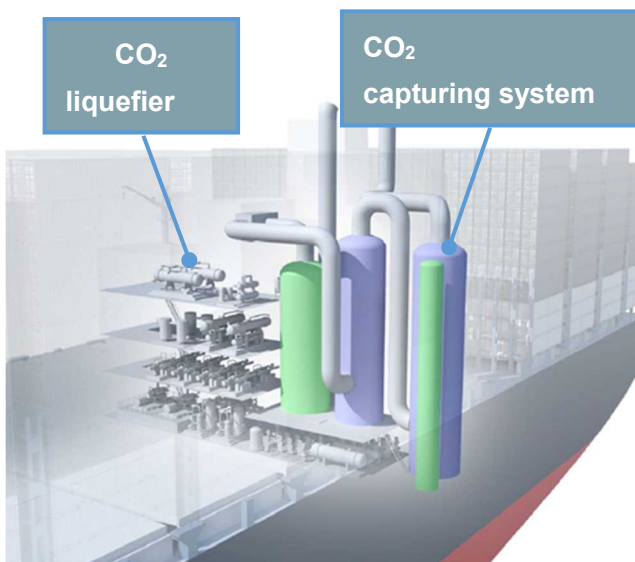

Figure Appendix 3.3-6: 20,000 TEU Container Ship's CO<sub>2</sub> Capturing System

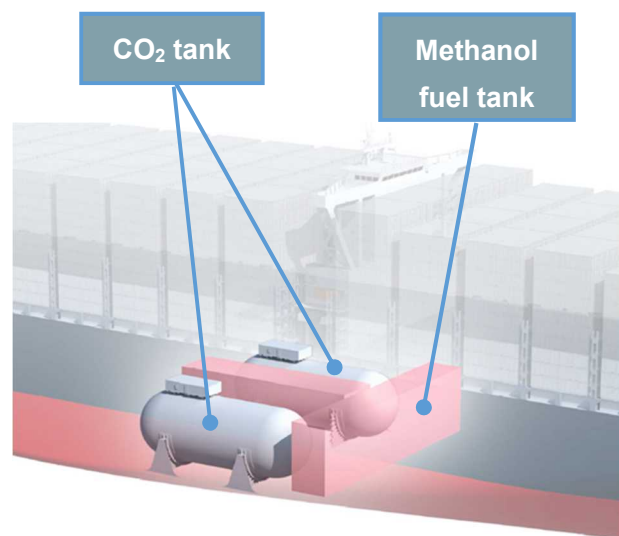

Figure Appendix 3.3-7: 20,000 TEU Container Ship's CO<sub>2</sub> and Methanol Tanks

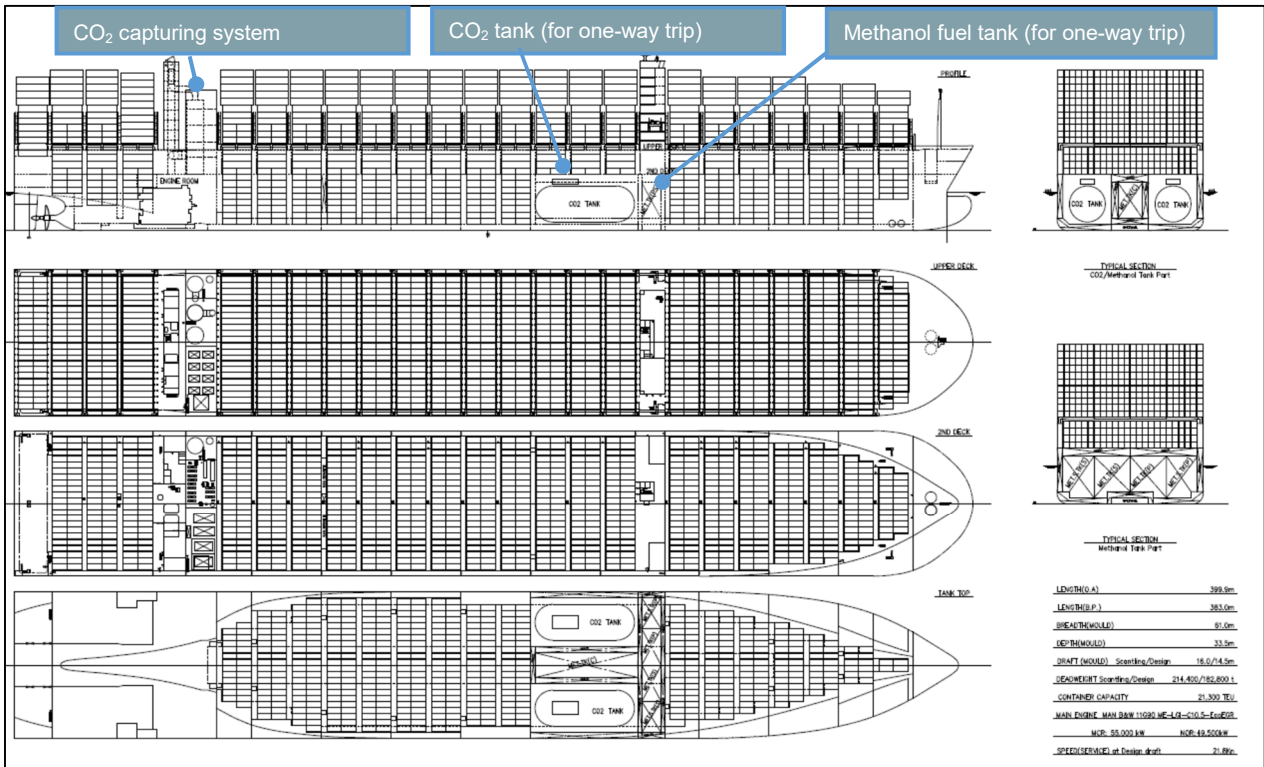

Figure Appendix 3.3-8: General Arrangement of the 20,000 TEU Container Ship with an Onboard CO<sub>2</sub> Capturing System

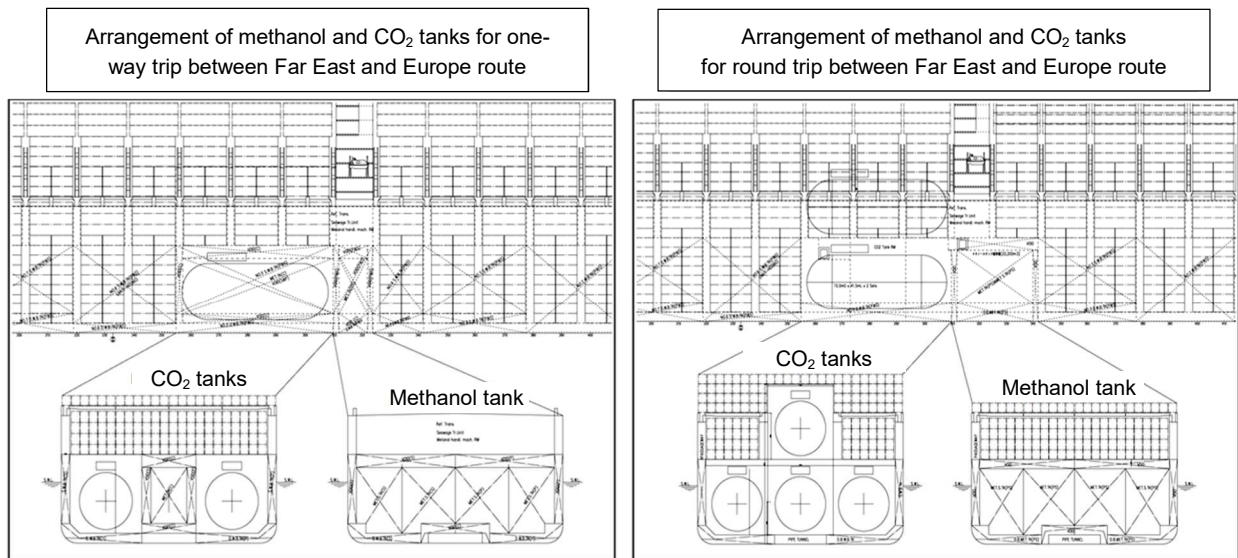

Figure Appendix 3.3-9: Position of Methanol and CO<sub>2</sub> Tanks in the 20,000 TEU Container Ship with an Onboard CO<sub>2</sub> Capturing System

Table Appendix 3.3-2: Comparison of the Impact of the Methanol and CO<sub>2</sub> Tanks on the Capacity of the 20,000 TEU Container Ship with an Onboard CO<sub>2</sub> Capturing system

Methanol tank	Far East -- Europe (for one-way trip): 13,200 m <sup>3</sup>	Far East -- Europe (for round trip): 23,400 m <sup>3</sup>
CO <sub>2</sub> tank	6400m <sup>3</sup> x 2 sets	6400m <sup>3</sup> x 4 sets
Impact on the capacity	Approx. – 1,820 TEU	Approx. – 2,550 TEU

### (3) Technological Issues to be Addressed for Practical Use of the Onboard CO<sub>2</sub> Capturing Ship

The following issues were identified through consideration of this concept design.

#### A. Systems for capturing and liquefying CO<sub>2</sub>

The systems and technologies have already been proven and applied to many onshore large facilities. Upon consideration, it is concluded that the systems can be installed and used on a ship without fundamental technical problem. While the following need to be verified and improved in the detailed design phase, all the issues would be solved in the future.

- Consideration of the ship's motion during navigation
- Handling of the amine solution for CO<sub>2</sub> absorption
- Countermeasures against saltwater damage (depending on where the system is installed)
- Height of equipment (CO<sub>2</sub> absorption tower and CO<sub>2</sub> reclamation tower) and vibration countermeasures
- Improvement of the CO<sub>2</sub> capturing rate (The capturing rate of the overall system for capturing and liquefying CO<sub>2</sub>, which was considered this time, was estimated to be 85.7% while the CO<sub>2</sub> reduction rate of the ship was estimated to be 80.3%.)
- Reduction of power for the liquefier (E.g., Introduction of cryogenic decompression will increase operations and maintenance work performed by the crew)
- Size reduction, energy conservation and cost reduction

#### B. Other

- Reducing the production cost of methanol fuels
- Accurate measurement and recording systems (amount of captured CO<sub>2</sub> and CO<sub>2</sub> reduction rate)
- Equipment for bunkering methanation fuels and unloading CO<sub>2</sub>

- Development of a methanol-fueled auxiliary engine
- Development of a large, high-efficiency shaft generator (as an alternative to the development of a methanol-fueled auxiliary engine)
- Development of a methanol-fueled boiler

## 4. Super-efficient LNG-fueled Ships

### (1) Concept Design

The project developed concept designs for a bulk carrier and a container ships using a combination of LNG fuel and other available energy efficiency technologies to achieve 80% or greater efficiency improvement over the 2008 level. Specifically, the concept was designed for a ship to have 80% or lower EEDI compared to the reference line.

### (2) Concept Ship Specifications

#### A. Bulk carrier

##### 1) Basic specifications

The basic specifications of the concept ship are shown in Table Appendix 3.4-1. This concept ship was designed so that it would not be subject to additional berth restrictions and conditions other than those for the base ship (an existing 80,000 DWT bulk carrier) while loading capacity was increased to allow slow steaming without losing transport capacity.

Table Appendix 3.4-1: Basic Specifications of the Concept Bulk Carrier

Major dimensions (m)	Loa / Lpp / Bm / D / ds / dd: 229.0 / 225.0 / 42.0 / 20.6 / 14.45 / 12.20		
Loading capacity	102,000 DWT		
Designed speed	11.5 kn (@NOR/15%SM)		
Fuel	LNG		
Propulsion system	Hybrid contra-rotating propeller system with a pod propeller and single-shaft electric propulsion		
Generator engine	Type & Manufacturer: 10V31DF, Wärtsilä		
	SMCR: 5,500 kW		
	Number of sets: 2 sets		
Propulsion motor		Main propulsion motor	POD
	Rated output	1,750 kW	3,500 kW
	Number of set	2	1
	Type & Manufacturer	PV500, GE	MERMAID POD, KONGSBERG
Innovative energy-saving technology	Sail for wind propulsion (40m x 15m x 6 sets), air lubrication system		

##### 2) Overview of the adopted technologies and EEDI improvement

Table Appendix 3.4-2 summarized EEDI improvement achieved by each of the technologies adopted to the concept ship in a step-by-step manner. Based on data from the latest eco-ships, an approx. 21% improvement over the 2008 level of the base ship was already achieved in 2019 due to the improvement of the hull form, and the year 2019 level was specified as Step 1. Technical and operational improvements (in terms of less maximum load required) used in Steps 2 to 6 were added to this, improving EEDI by 86% from the reference line.

Table Appendix 3.4-2: Overview of the Adopted Technologies and EEDI Improvement

	Base ship (2008 level)	Step 1	Step 2	Step 3	Step 4	Step 5	Step 6
		Improved hull form (2019 level)	+ Design optimization for slow steaming	+ Upsizing	+ Hybrid contra-rotating propeller system (single-shaft electric propulsion & pod)	+ Fuel conversion to LNG	+ Innovative energy-saving technologies
Lpp (m)	222.0	225.0	225.0	225.0	225.0	225.0	225.0
B (m)	32.24	32.24	32.24	42.0	42.0	42.0	42.0
D (m)	20.1	20.1	20.1	20.1	20.1	20.1	20.1
d <sub>s</sub> (m)	14.45	14.45	14.45	14.45	14.45	14.45	14.45
d <sub>d</sub> (m)	12.20	12.20	12.20	12.20	12.20	12.20	12.20
DWT	83,000	81,000	81,000	102,000	102,000	102,000	102,000
M/E MCR (kW)	11,060	9,660	4,200	4,800	3,940 <sup>1</sup>	3,940 <sup>1</sup>	3,940 <sup>1</sup>
Design speed (knots)	14.5	14.5	11.5	11.5	11.5	11.5	11.5
Fuel	HFO	HFO	HFO	HFO	HFO	LNG	LNG
Innovative energy-saving technologies	N/A	N/A	N/A	N/A	N/A	N/A	Sail for wind propulsion (40m x 15m x 6 sets) & air lubrication system
EEDI Improvement (Compared to the previous Step)	-	21%	41%	10%	-6%	23%	61%
EEDI Improvement (cumulative)	-	21%	53%	58%	55%	65%	86%

1. Rated output of propulsion motor

### Design optimization for speed reduction and upsizing (Step 2 and Step 3)

In the next two steps, the ship design was changed to reduce the speed (Step 2) and upsize the ship (Step 3). At present, shipping companies have widely implemented the slow steaming allowing operation with lower engine output. However, in principle, slow steaming reduces transport capacity of the ship. Therefore, in order to allow further slow steaming without reducing the ship's transport capacity, the deadweight of the concept ship was upsized so that its transportation capacity (cruising speed x DWT) would be maintained. In upsizing the ship, its width was increased while its hull length nor draft was unchanged, to prevent additional berth restrictions and conditions other than those of the base ship. The ship size was increased to the upper limit at which a significant decline in the ship's propulsion performance and maneuverability can be avoided. This process resulted in the ship being upsized to 42.0 meters wide and a capacity of 102,000 DWT. A design speed of 11.5 kn was set as it would maintain transportation capacity under the aforementioned conditions. Consequently, the EEDI value was improved by approx. 41% due to the significant decline in the main engine power and by approx. 10% due to the upsizing. In order to maintain the maneuverability in adverse conditions, as required by the MARPOL Convention, introduction of an emergency power reserve was assumed in this concept design.

### Hybrid contra-rotating propeller system with a pod propeller and single-shaft electric propulsion (Step 4)

A hybrid contra-rotating propeller system with a pod propeller and single-shaft electric propulsion was adopted to improve the maneuverability with the pod propulsion. Use of two propellers allows further improvement in propeller efficiency, resulting in an approx. 10% efficiency improvement.

A rendering of this propulsion system is shown in Figure Appendix 3.4-1, and specifications of the main propeller and the pod propeller are shown in Table Appendix 3.4-3. A 50:50 ratio was set for the sharing of propulsion power between the main propeller and the pod propeller.

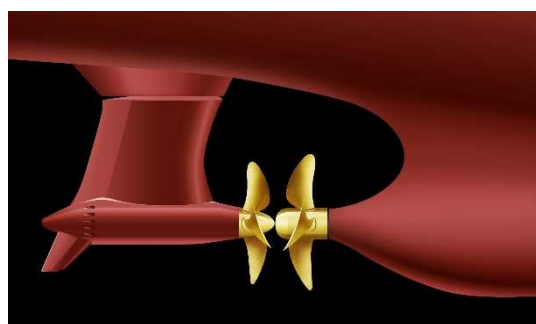

Figure Appendix 3.4-1: Hybrid Contra-rotating Propeller System



Table Appendix 3.4-3: Specifications of the Main Propeller and Pod Propeller

	Pod	Main propeller
Diameter (m)	5.9	6.7
Number of blades	4	4
Revolutions (RPM)	80	60

As a result of the introduction of electric propulsion, the EEDI value worsened by approx. 9% due to mechanical and electrical loss in the power generator, converter, and motor and by 1.5% due to loss of propulsion power at the speed reducer, respectively. In addition, EEDI value worsened approx. 6% due to a decline in fuel efficiency resulting from the change of the main propulsion engine from a 2-stroke engine to a 4-stroke generator engine. The total impact of adopting this system is an approx. 6% worsening of the EEDI value.

Although there are various options to compensate for the decline in ship maneuverability caused by the wider hull and lower propulsion power, including use of two propeller shafts and electric systems, the above system was adopted in this concept design for the following reasons:

- A two-engine two-shaft system consisting of two pairs of directly connected engines and shafts has an advantage in efficiency improvement. However, the electric propulsion and pod system allow higher flexibility of the engine room location and provide significant improvement of ship maneuverability.; and
- Although the electric propulsion system results in worse energy efficiency, the system has further potential to reduce GHG emissions with improvements in power generation efficiency possibly supported by utilization of renewable energy and in the performance of large-capacity batteries.

#### Fuel conversion to LNG (Step 5)

As Table Appendix 3.4-4-1 shows, the adoption of LNG fuel reduces the CO<sub>2</sub> conversion factor and improved specific fuel consumption of main and auxiliary engines. As a result, the EEDI value improved approx. 23%. Specific fuel consumption for LNG fuel was set at 158 g/kWh and 5.0 g/kWh for the pilot fuel.

The LNG tanks are IMO Type-C tanks positioned on the upper deck and on both sides of the funnel. Total tank capacity was set at 3,800 m<sup>3</sup> on the assumption of a round trip on the north-south route (between Japan and Australia).

Table Appendix 3.4-4-1: Comparison of CO<sub>2</sub> Conversion Factor and Specific Fuel Consumption

	CO <sub>2</sub> conversion factor (C <sub>F</sub> )	Specific fuel consumption (SFC)
Diesel / Gas Oil	3.206 t-CO <sub>2</sub> /t-Fuel	Approx. 180 g/kWh
LNG	2.750 t-CO <sub>2</sub> /t-Fuel	Approx. 160 g/kWh

Innovative energy-saving technology (wind propulsion system) (Step 6)

A total of six sails for wind propulsion were positioned, one in each space between the cargo holds, to reduce the propulsion power needed from the engines through use of wind power. Each sail is 40 meters high and 15 meters wide, and the bridge was positioned at the bow to secure visibility from the navigation bridge. The sails are 4-stage telescopic sails, which can be shortened when necessary. This will not only ensure safety in adverse weather conditions but also reduce wind resistance when the ship is going against the wind.

The effect of wind power on energy efficiency improvement is estimated to be approx. 5% in each sail, based on the wind probability along the route between Japan and east coast of Australia in a project.<sup>45</sup> Therefore, based on factors including the difference in the number of sails between that project and this concept ship, the reduction of main engine power was calculated to be 2,000 kW.

However, more data on the characteristics of the wind propulsion system and on the wind probability are needed to fairly evaluate the wind propulsion system under the EEDI framework. Such evaluation, namely method of EEDI calculation and certification, needs to be developed by the IMO.

Innovative energy-saving technology (air lubrication system) (Step 6)

An air lubrication system using a scavenging air bypass was installed, aiming for further reduction of propulsion power. This system takes scavenged air and directs it to the bottom of the ship, thereby reducing the friction between the ship hull and the seawater, so as to improve energy efficiency. According to data from a 100,000 DWT bulker built in Japan, the system reduces the necessary main engine power by approx. 4%.<sup>46</sup>

<sup>45</sup> A report from Mitsui O.S.K. Lines, Ltd. entitled “*Wind Challenger Project-no jitsugen ni mukete* (towards achieving the Wind Challenger Project)” that was presented at an environmental seminar entitled “*Datsu-tanso jidai ni muketa miraigata furyoku-sen kaihatsu no genjo* (current status of development of wind powered ship of the future for the era of decarbonization),” which was held by Nippon Kaiji Kyokai (ClassNK) in 2019

<sup>46</sup> A press release entitled “New Coal Carrier Prepares to Sail with an Innovative Air-Lubrication System,” Nippon Yusen Kabushiki Kaisha

### 3) EEDI calculation

EEDI was calculated as follows in accordance with the relevant guidelines and guidance.

#### Design specifications

- $MPP_{Motor}$  (for EEDI calculation): 3,940 (kW)
- $SFC_{ME(i)}$ :
  - $SFC_{ME(i)_{Gasfuel}}$ : 158 (g/kWh)
  - $SFC_{ME(i)_{Pilotfuel}}$ : 5.0 (g/kWh)
- Deadweight : 102,000 (ton)

#### Vref (2.2.6 of the EEDI calculation guidelines)<sup>47</sup>

Based on the designed speed of 11.5 kn which includes a sea margin of 15% at the designed draft (dd = 12.2 m), Vref at 83% of  $MPP_{Motor}$  at EEDI draft (ds = 14.45) was estimated. Further, the 1.5% propulsion power loss of the speed reducer was also considered. As a result, Vref was calculated to be 10.82 kn.

#### Capacity (EEDI condition) (2.2.3 of the EEDI calculation guidelines)

For a bulk carrier, DWT should be used to indicate capacity. Accordingly, 102,000 (tons) was used in the calculation.

#### $P_{ME}$ (2.2.5.1 of the EEDI calculation guidelines)

$$\begin{aligned} P_{ME} &= 0.83 \times \frac{MPP_{Motor}}{\eta} \\ &= 0.83 \times \frac{3,940}{0.913} \\ &= 3,582(\text{kW}) \end{aligned}$$

$\eta$  indicates the power generation efficiency. For the concept ship, the default value of 0.913, which is stipulated in the guidelines, was used.

---

<sup>47</sup> 2018 GUIDELINES ON THE METHOD OF CALCULATION OF THE ATTAINED ENERGY EFFICIENCY DESIGN INDEX (EEDI) FOR NEW SHIPS (MEPC.308(73))

P<sub>AE</sub> (2.2.5.6 of the EEDI calculation guidelines)

$$\begin{aligned} P_{AE} &= 0.05 \times MPP_{Motor} \\ &= 0.05 \times 3,940 \\ &= 197 \text{ (kW)} \end{aligned}$$

Wind propulsion system (Appendix 02 of the guidance on treatment of innovative energy efficiency technologies)<sup>48</sup>

As the value for the effect of the wind propulsion system (sail) for reducing propulsion power, 2,000 kW was adopted as indicated below, referring to a report on a project in Japan.

$$f_{eff} \cdot P_{eff} = 2,000 \text{ (kW)}$$

$f_{eff}$ : Availability factor of the effect of the system

$P_{eff}$ : Value of the reduced propulsion power which can be included in EEDI calculation

Air lubrication system (Appendix 01 of the guidance on treatment of innovative energy efficiency technologies)

The effect of the air lubrication system is assumed to be 380 kW reduction in the necessary propulsion power, based on data from a ship built in Japan.

$$f_{eff} \cdot P_{eff} = 380 \text{ (kW)}$$

$f_{eff}$ : Availability factor of the effect of the system.  $f_{eff}=1.0$  in the case of the air lubrication system.

$P_{eff}$ : Value of the reduced propulsion power which can be included in EEDI calculation

Capacity correction factor ( $f_{iCSR}$ ) (2.2.11.3 of the EEDI calculation guidelines)

$$\begin{aligned} f_{iCSR} &= 1 + (0.08 \cdot LWT / DWT) \\ &= 1 + 0.08 \cdot 16,300 / 102,000 \\ &= 1.0128 \end{aligned}$$

---

<sup>48</sup> 2013 GUIDANCE ON TREATMENT OF INNOVATIVE ENERGY EFFICIENCY TECHNOLOGIES FOR CALCULATION AND VERIFICATION OF THE ATTAINED EEDI (MEPC.1/Circ.815)

## Attained EEDI (Chapter 2 of the EEDI calculation guidelines)

$$\begin{aligned}
 EEDI &= \frac{P_{ME} (C_{FME\_Gas} \cdot SFC_{ME\_Gasfuel} + C_{FME\_Pilot} \cdot SFC_{ME\_Pilotfuel})}{f_{iCSR} \cdot Capacity \cdot V_{ref}} \\
 &+ \frac{P_{AE} (C_{FAE\_Gas} \cdot SFC_{AE\_Gasfuel} + C_{FAE\_Pilot} \cdot SFC_{AE\_Pilotfuel})}{f_{iCSR} \cdot Capacity \cdot V_{ref}} \\
 &- \frac{\sum_{i=1}^{n_{eff}} f_{eff(i)} \cdot P_{eff(i)} \cdot C_{FME} \cdot SFC_{ME}}{f_{iCSR} \cdot Capacity \cdot V_{ref}} \\
 &= \frac{3,582 \times (2.75 \times 158 + 3.206 \times 5.0) + 197 \times (2.75 \times 158 + 3.206 \times 5.0) - (2,000 + 380) \times 2.75 \times 158}{1.0128 \times 102,000 \times 10.82} \\
 &= 0.598 (g / ton \cdot mile)
 \end{aligned}$$

## EEDI improvement

Original EEDI(year 2008 level as the benchmark) = 4.383 (g/ton · mile)

$$EEDI \text{ Reduction Rate (vs. Original EEDI)} = 1 - \frac{0.598}{4.383} = \mathbf{86\%}$$

### 4) Assessment of the minimum propulsion power

A level 2 assessment was conducted following the current guidelines for determining minimum propulsion power.<sup>49</sup> Factors used for the assessment are as follows:

- Hull form data, form factor, and self-propulsion factor: Estimated by applying the Type Ship method;
- Wind pressure resistance: Calculated by applying Fujiwara's formula<sup>50</sup>;
- Added resistance of waves: Calculated by applying a method from the National Maritime Research Institute<sup>51</sup>;
- Required headway: Required headway fluctuates between 4 kn and 9 kn in accordance with the rudder area and other factors. The higher the turning performance of the ship is, the lower the required headway is. For this concept ship, the required headway was set at 4 kn, the lower limit, assuming that it has sufficient turning performance due to the adoption of the pod propeller.; and
- Torque characteristics: The concept ship is an electrically propelled ship, whose engines are driven in constant torque control mode. Therefore, as the load diagram in Figure Appendix 3.4-2 shows, its torque limit is higher than that of ordinary propulsion systems with directly connected engines.

<sup>49</sup> 2013 INTERIM GUIDELINES FOR DETERMINING MINIMUM PROPULSION POWER TO MAINTAIN THE MANOEUVRABILITY OF SHIPS IN ADVERSE CONDITIONS (MEPC.1/Circ.850)

<sup>50</sup> Fujiwara T., Ueno M., Ikeda Y. Cruising performance of a large passenger ship in heavy sea, Proc. of Sixteenth International Offshore and Polar Engineering Conference, Vol. III, 2006

<sup>51</sup> Tsujimoto M., Shibata K., Kuroda M., Takagi K. A Practical Correction Method for Added Resistance in Waves. J. JASNAOE, Vol. 8, 2008

As a result of assessment conducted by using PrimeShip-GREEN/MinPower software, it was confirmed that the minimum power requirement is fulfilled if the rated output of the motor is 7,000 kW or higher, as shown in Table Appendix 3.4-5. Accordingly, assuming that the emergency power reserve concept is adopted at the IMO, 7,000 kW, which fulfills the minimum required propulsion power output, was set as the registered propulsion power to maintain maneuverability in adverse condition, and the restricted propulsion power of 3,940 kW for the normal operation was used for EEDI calculation.

Table Appendix 3.4-5: Results of the Assessment of Minimum Propulsion Power  
(calculated by PrimeShip-GREEN/MinPower)

Adverse conditions											
1	Number		1	2	3	4	5	6	7	8	9
2	Significant wave height	(m)	$h_s$	4.75	4.75	4.75	4.75	4.75	4.75	4.75	4.75
3	Peak wave period	(s)	$T_P$	7.0	8.0	9.0	10.0	11.0	12.0	13.0	14.0
4	Mean wind speed	(m/s)	$V_W$	17.35	17.35	17.35	17.35	17.35	17.35	17.35	17.35
5	Required ship advance speed through the water in head wind and waves	(m/s)	$V_s$	2.06	2.06	2.06	2.06	2.06	2.06	2.06	2.06
		(knot)		4.00	4.00	4.00	4.00	4.00	4.00	4.00	4.00
6	Relative wind speed	(m/s)	$V_{W,rel}$	19.41	19.41	19.41	19.41	19.41	19.41	19.41	19.41
Resistance in adverse conditions											
7	Calm-water resistance	(kN)	$R_{cw}$	71.36	71.36	71.36	71.36	71.36	71.36	71.36	71.36
8	Aerodynamic resistance	(kN)	$R_{air}$	141.21	141.21	141.21	141.21	141.21	141.21	141.21	141.21
9	Added resistance in long-crested irregular waves	(kN)	$R_{aw}$	458.25	485.28	525.12	592.84	685.17	717.04	680.19	599.24
Calculation of required brake power and torque in adverse conditions											
10	Required propeller thrust	(kN)	$T$	849.15	883.37	933.79	1019.51	1136.39	1176.73	1130.09	1027.62
11	Load factor		$K_T/J^2$	12.104	12.592	13.311	14.533	16.199	16.774	16.109	14.648
12	Advanced coefficient		$J$	0.218	0.214	0.209	0.201	0.191	0.188	0.192	0.200
13	Propeller revolution	(rpm)	$N$	50.75	51.65	52.95	55.07	57.83	58.75	57.68	55.27
14	Torque coefficient		$K_Q$	0.0681	0.0683	0.0686	0.0690	0.0695	0.0697	0.0695	0.0691
15	Required brake power	(kW)	$P_{B,req}$	3624	3831	4143	4691	5471	5749	5428	4744
16	Required torque	(kN·m)	$Q_{req}$	681.86	708.32	747.29	813.44	903.47	934.51	898.62	819.69
Load diagram corresponding to propeller revolution											
17	Brake power on load diagram	(kW)	$P_{B,LD}$	4448	4607	4841	5237	5774	5959	5745	5275
18	Torque on load diagram (Maximum torque)	(kN·m)	$Q_{max}$	836.97	851.79	873.13	908.17	953.54	968.68	951.15	911.40
Judgement											
19	Judgement		$P_{B,req} \leq P_{B,LD}$	OK	OK	OK	OK	OK	OK	OK	OK
20			$P_{B,req} / P_{B,LD}$	81.5%	83.2%	85.6%	89.6%	94.7%	96.5%	94.5%	89.9%

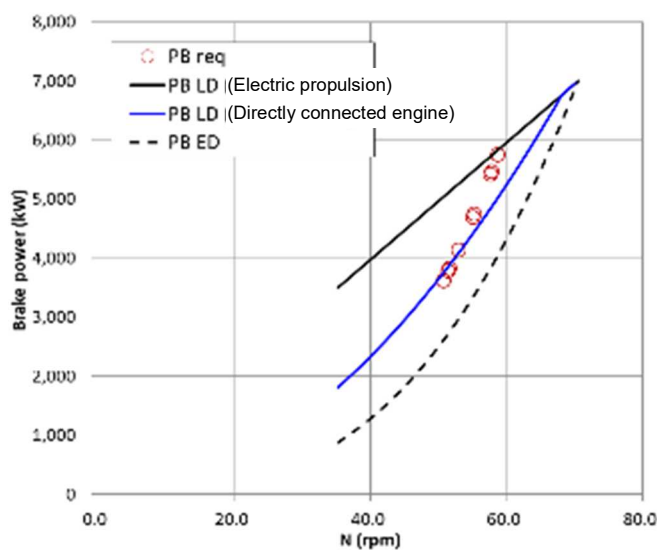

Figure Appendix 3.4-2: Load Diagram and Results of the Assessment of Minimum Propulsion Power

## B. Container ship

### 1) Basic specifications

Basic specifications of the concept design are shown in Table Appendix 3.4-6. This concept ship was designed so that it will be able to be engaged in the Europe-Asia route and navigate through the Suez Canal while loading capacity was increased from an existing 20,000TEU container ship (the model ship) to allow further slow steaming without reducing transport capacity.

Table Appendix 3.4-6: Basic Specifications of the Container Ship

Major dimensions (m)	Loa / Lpp / Bm / D / ds / dd :400.0 / 387.0 / 69.2 / 33.2 / 16.0 / 13.0		
Loading capacity	270,000DWT / 30,000TEU (incl.1,500 Ref.con)		
Design speed	15.2 kn (@NOR/15%SM)		
Fuel	LNG		
Propulsion system	Hybrid contra-rotating propeller system with a pod propeller and single-shaft electric propulsion		
Generator engine	Type & Manufacturer : 12V50DF (2sets) / 8L50DF (2sets), Wärtsilä		
	SMCR : 11,700 kW / 7,800 kW		
	Number of set : 4 sets in total		
Propulsion motor		Main propulsion motor	POD
	Rated output	5,500 kW	11,000 kW
	Number of set	2	1
	Type & Manufacturer	N37 HY630S4C, GE	MERMAID POD, KONGSBERG
Innovative energy-saving technology	Kite for wind propulsion, air lubrication system		

### 2) Overview of the adopted technologies and EEDI improvement

Table Appendix 3.4-7 summarized EEDI improvement achieved by each of the technologies adopted to the concept ship are in a step-by-step manner. Based on data from the latest eco-friendly ships, it was assumed that an approx. 50% improvement over the 2008 level of the base ship is already achieved in 2019 due to the improvement of the hull form and design speed reduction, and the year 2019 level was specified as Step 1. Technical and operational improvements used in Steps 2 to 6 were added to this, improving EEDI by 86% from the reference line.

Table Appendix 3.4-7: Overview of the Adopted Technologies and EEDI Improvement

	Base ship (2008 level) <sup>1</sup>	Step 1	Step 2	Step 3	Step 4	Step 5	Step 6
		Improved hull form & design speed reduction (2019 level)	+ Further design optimization for slow steaming	+ Upsizing	+ Hybrid contra-rotating propeller system (single-shaft electric propulsion & pod)	+ Fuel conversion to LNG	+ Innovative energy-saving technologies
Lpp (m)	387.0	387.0	387.0	387.0	387.0	387.0	387.0
B (m)	58.8	58.8	58.8	69.2	69.2	69.2	69.2
D (m)	32.9	32.9	32.9	33.2	33.2	33.2	33.2
d <sub>s</sub> (m)	16.0	16.0	16.0	16.0	16.0	16.0	16.0
d <sub>d</sub> (m)	14.5	14.5	14.5	13.0	13.0	13.0	13.0
DWT	199,692	199,692	199,692	270,000	270,000	270,000	270,000
TEU	20,000	20,000	20,000	30,000	30,000	30,000	30,000
M/E MCR (kW)	132,440	59,300	18,700	18,900	16,200 <sup>2</sup>	16,200 <sup>2</sup>	16,200 <sup>2</sup>
Design speed (knots)	29.2	22.8	15.2	15.2	15.2	15.2	15.2
Fuel	HFO	HFO	HFO	HFO	HFO	LNG	LNG
Innovative energy-saving technologies	N/A	N/A	N/A	N/A	N/A	N/A	Towing kite & air lubrication system
EEDI improvement (Compared to the previous Step)	-	50%	51%	23%	-11%	26%	10%
EEDI improvement (cumulative)	-	50%	76%	81%	79%	84%	86%

1. As of 2008, no actual 20,000 TEU container ship existed. However, a 20,000 TEU container ship equivalent to the reference line was designed as a virtual model.

2. Rated output of propulsion motor

#### Design optimization for speed reduction and upsizing (Step 2 and Step 3)

The ship design was changed to further reduce speed (Step 2) and upsize the ship (Step 3). Here, in the same manner as that in the bulk carrier, the ship was upsized to allow further slow steaming without reducing the ship's transport capacity (cruising speed x TEU). In upsizing the ship, its width was increased while its hull length was unchanged, to prevent additional berth restrictions and conditions other than those of the base ship. The ship size was increased to the optimal size in consideration of profitability. It resulted in the ship being upsized to 69.2 meters wide with a capacity of 30,000 TEU. A design speed of 15.2 kn was set as the speed at which transportation capacity can be maintained under



the above conditions. Consequently, the EEDI value was improved by approx. 51% due to the significant decline in the main engine power and by approx. 23% due to the upsizing. In order to maintain the maneuverability in adverse conditions, as required by the MARPOL Convention, introduction of an emergency power reserve was assumed in this concept design.

This concept ship is assumed to travel the route between Europe and Asia. While the maximum draft of a 69.2-meter-wide ship that can pass through the Suez Canal is 12.9 m, the designed draft was set at 13.0 m, taking into account the reduction of draft attributed to fuel consumption and other changes that will take place during the journey to the Suez Canal. Further, to secure space for containers, the crew accommodation space was positioned on both sides of the funnel, which was expanded due to the increase of the beam, and the bridge was positioned at the bow to secure visibility from the navigation bridge.

In addition, because the strength of the double bottom structure against push-up load is lowered by the increased width, the double bottom was made 30 cm thicker to compensate for the decline of the strength. As a result, depth became 33.2 m.

#### Hybrid contra-rotating propeller system with a pod propeller and single-shaft electric propulsion (Step 4)

A hybrid contra-rotating propeller system with a pod propeller and single-shaft electric propulsion was chosen to improve maneuverability. Use of two propellers allows further improvement in propeller efficiency, resulting in an approx. 6% efficiency improvement.

A rendering of this propulsion system is shown in Figure Appendix 3.4-3, and the specifications of the main propeller and the pod propeller are shown in Table Appendix 3.4-8. A 50:50 ratio was set for the sharing of propulsion power between the main propeller and the pod propeller.

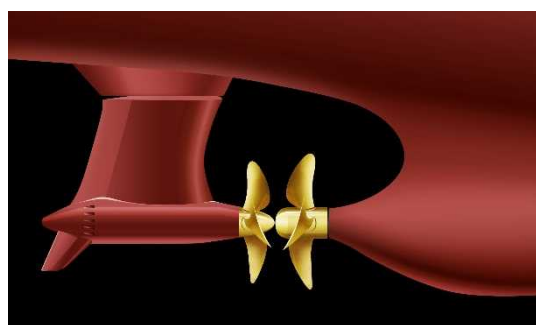

Figure Appendix 3.4-3: Hybrid Contra-rotating Propeller System

Table Appendix 3.4-8: Specifications of the Main Propeller and Pod Propeller

	POD	Main propeller
Diameter (m)	5.9	6.7
Blades number	4	4
Revolution (RPM)	80	60

As a result of the introduction of electric propulsion, EEDI value worsened approx. 9% due to mechanical and electrical loss in the power generator, converter, and motor and 1.5% due to the loss of propulsion power at the speed reducer. In addition, EEDI value worsened approx. 7% due to a decline in fuel efficiency resulting from the change of the main propulsion engine from a 2-stroke main engine to a 4-stroke generator engine. The total impact of adopting this system is approx. 6% worsening of the EEDI value.

The above system was adopted in this concept design for the following reasons:

- While the above losses are unavoidable due to the introduction of electric propulsion, the system has potential for further efficiency improvement in the future, as was also the case for the bulk carrier; and
- For a container ship with low propulsion power as assumed in this concept design, onboard power demand for freezing containers and other usage is relatively high compared to other ship types. In such a case, the electric propulsion system allows flexibility in onboard supply of electric power.
- In addition, the electric propulsion system saves more space than the conventional system consisting of directly connected engine and auxiliary engine for power generation.

#### Fuel conversion to LNG (Step 5)

LNG fuel was chosen to improve energy efficiency significantly. The EEDI value was improved by approx. 26% due to a decline in the CO<sub>2</sub> conversion factor and an improvement of the specific fuel consumption of main and auxiliary engines, as shown in Table Appendix 3.4-4-2. The specific fuel consumption for LNG fuel was set at 155 g/kWh and 1.5 g/kWh for the pilot fuel.

The LNG tanks are membrane-type tanks positioned around the engine room. Total tank capacity was set at 11,000m<sup>3</sup> assuming a round trip on the route between Europe and Asia.

Table Appendix 3.4-4-2: Comparison of CO<sub>2</sub> Conversion Factor and Specific Fuel Consumption

	CO <sub>2</sub> conversion factor (C <sub>F</sub> )	Specific fuel consumption (SFC)
Diesel / Gas Oil	3.206 t-CO <sub>2</sub> /t-Fuel	Approx. 180 g/kWh
LNG	2.750 t-CO <sub>2</sub> /t-Fuel	Approx. 155 g/kWh

### Innovative energy-saving technology (wind propulsion system) (Step 6)

A towing kite was adopted to reduce the propulsion power through use of wind power. Kite deployment, manipulation while in use, and stowage is all electronically controlled. It is optimized to produce the greatest possible effect for the wind conditions. According to a report<sup>52</sup> from the manufacturer, the employment of the kite is estimated to improve EEDI value by 23.7% on a Panamax bulker. For the concept ship, the system's reduction of necessary propulsion power by 1,000 kW was included in the calculation in consideration of the margin.

The same as the concept design for a bulk carrier, in order to fairly evaluate the wind propulsion system under the EEDI framework, method of EEDI calculation and certification need to be developed by the IMO.

### Innovative energy-saving technology (air lubrication system) (Step 6)

As in the bulk carrier, an air lubrication system was installed on this concept ship to further reduce the necessary propulsion power, and the same level of effect was expected.

### 3) EEDI calculation

EEDI was calculated as follows in accordance with relevant guidelines and guidance.

#### Design specifications

- $MPP_{Motor}$  (for EEDI calculation): 16,200 (kW)
- $SFC_{ME(i)}$ :
  - $SFC_{ME(i)_{Gasfuel}}$  : 155 (g/kWh)
  - $SFC_{ME(i)_{Pilotfuel}}$  : 1.5 (g/kWh)
- Deadweight : 270,000 (ton)

#### Vref (2.2.6 of the EEDI calculation guidelines)

As in the bulk carrier, the Vref used herein was estimated based on the design speed. Considering the design speed of 15.2 kn which includes a sea margin of 15% at the designed draft ( $dd = 13.0$  m), Vref at 83% of  $MPP_{Motor}$  at EEDI draft ( $d_{70\%DWT} = 12.79$ m) was estimated. Further, the 1.5% propulsion power loss of the speed reducer was also considered. As a result, Vref was calculated to be 14.96 kn.

---

<sup>52</sup> The report from Kawasaki Kisen Kaisha, Ltd. and Airseas entitled “*Airseas-sha-sei kite wo riyou shita shoene kiki-no saiyo ni tsuite* (Adoption of energy-saving equipment using an Airseas kite)” presented at the environmental seminar, “*Datsu-tanso ni muketa miraigata furyoku-sen kaihatsu no genjo* (current status of the development of wind powered ships of the future for the decarbonization era),” held by Nippon Kaiji Kyokai (ClassNK) in 2019.

### Capacity (EEDI condition) (2.2.3 of the EEDI calculation guidelines)

The capacity of container ships is 70% of DWT. Accordingly,  $270,000 \times 0.7 = 189,000$  (tons) was used for the calculation.

### $P_{ME}$ (2.2.5.1 of the EEDI calculation guidelines)

$$\begin{aligned} P_{ME} &= 0.83 \times \frac{MPP_{Motor}}{\eta} \\ &= 0.83 \times \frac{16,200}{0.913} \\ &= 14,727(\text{kW}) \end{aligned}$$

$\eta$  indicates the power generation efficiency. For the concept ship, the default value of 0.913, which is stipulated in the guidelines, was used.

### $P_{AE}$ (2.2.5.6 of the EEDI calculation guidelines)

$$\begin{aligned} P_{AE} &= 0.025 \times MPP_{Motor} + 250 \\ &= 0.025 \times 16,200 + 250 \\ &= 655(\text{kW}) \end{aligned}$$

### Wind propulsion system (Appendix 02 of the guidance on treatment of innovative energy efficiency technologies)

The effect of the wind propulsion system (kite) is assumed to be 1,000 kW reduction in the necessary propulsion power, according to information material from the manufacturer.

$$f_{eff} \cdot P_{eff} = 1,000(\text{kW})$$

### Air lubrication system (Appendix 01 of the guidelines on treatment of innovative energy efficiency technologies)

The effect of the air lubrication system is assumed to be 600 kW reduction in the necessary propulsion power, based on data from a ship built in Japan and consideration on its difference in beam from the concept design.

$$f_{eff} \cdot P_{eff} = 600(\text{kW})$$

## Attained EEDI (Chapter 2 of the EEDI calculation guidelines)

$$\begin{aligned}
 EEDI &= \frac{P_{ME} (C_{FME\_Gas} \cdot SFC_{ME\_Gasfuel} + C_{FME\_Pilot} \cdot SFC_{ME\_Pilotfuel})}{f_{iCSR} \cdot Capacity \cdot V_{ref}} \\
 &+ \frac{P_{AE} (C_{FAE\_Gas} \cdot SFC_{AE\_Gasfuel} + C_{FAE\_Pilot} \cdot SFC_{AE\_Pilotfuel})}{f_{iCSR} \cdot Capacity \cdot V_{ref}} \\
 &- \frac{\sum_{i=1}^{n_{eff}} f_{eff(i)} \cdot P_{eff(i)} \cdot C_{FME} \cdot SFC_{ME}}{f_{iCSR} \cdot Capacity \cdot V_{ref}} \\
 &= \frac{14,727 \times (2.75 \times 155 + 3.206 \times 1.5) + 655 \times (2.75 \times 155 + 3.206 \times 1.5) - (1,000 + 600) \times 2.75 \times 155}{270,000 \times 14.96} \\
 &= 2.104 (g / ton \cdot mile)
 \end{aligned}$$

## EEDI improvement

*Original EEDI (year 2008 level as the benchmark) = 14.11 (g/ton · mile)*

$$EEDI \text{ Reduction Rate (vs. Original EEDI)} = 1 - \frac{2.104}{14.11} = \mathbf{86\%}$$

### 4) Assessment of the minimum propulsion power

Guidelines on the minimum propulsion power does not include guidance dedicated to container ships. Accordingly, guidance for bulkers and tankers were applied to conduct a Level 2 assessment. Factors used for the assessment are as follows:

- Hull form data, form factor, and self-propulsion factor: Estimated by applying the type ship method;
- Wind pressure resistance: Calculated by applying Fujiwara's formula<sup>53</sup>;
- Added resistance of waves: Calculated by applying a method from the National Maritime Research Institute<sup>54</sup>;
- Required headway: Required headway fluctuates between 4 kn and 9 kn in accordance with the rudder area and other factors. The higher the turning performance of the ship is, the lower the required headway is. For this concept ship, the required headway was set at 4 kn, which is the lower limit, assuming that it has sufficient turning performance due to the adoption of the pod propeller.; and
- Torque characteristics: The concept ship is an electrically propelled ship, whose engines are driven in constant torque control mode. Therefore, as the load diagram in Figure Appendix 3.4-4 shows, its torque limit is higher than that of ordinary propulsion systems with directly connected engines.

<sup>53</sup> Fujiwara T., Ueno M., Ikeda Y. Cruising performance of a large passenger ship in heavy sea, Proc. of Sixteenth International Offshore and Polar Engineering Conference, Vol. III, 2006

<sup>54</sup> Tsujimoto M., Shibata K., Kuroda M., Takagi K. A Practical Correction Method for Added Resistance in Waves. J. JASNAOE, Vol. 8, 2008

As a result of assessment conducted by using PrimeShip-GREEN/MinPower software, it was confirmed that the minimum power requirement is fulfilled if the rated output of the motor is 22,000 kW or higher, as shown in Table Appendix 3.4-9. Accordingly, assuming that the emergency power reserve is adopted at the IMO, 22,000 kW, which fulfills the minimum required propulsion power, was set as the registered propulsion power to maintain maneuverability in adverse condition, and the restricted propulsion power of 16,200 kW for the normal operation was used for EEDI calculation.

Table Appendix 3.4-9: Results of the Assessment of Minimum Propulsion Power  
(calculated by PrimeShip-GREEN/MinPower)

Adverse conditions												
1	Number			1	2	3	4	5	6	7	8	9
2	Significant wave height	(m)	$h_s$	5.50	5.50	5.50	5.50	5.50	5.50	5.50	5.50	5.50
3	Peak wave period	(s)	$T_P$	7.0	8.0	9.0	10.0	11.0	12.0	13.0	14.0	15.0
4	Mean wind speed	(m/s)	$V_W$	19.00	19.00	19.00	19.00	19.00	19.00	19.00	19.00	19.00
5	Required ship advance speed through the water in head wind and waves	(m/s)	$V_s$	2.06	2.06	2.06	2.06	2.06	2.06	2.06	2.06	2.06
				(knot)	4.00	4.00	4.00	4.00	4.00	4.00	4.00	4.00
6	Relative wind speed	(m/s)	$V_{W,rel}$	21.06	21.06	21.06	21.06	21.06	21.06	21.06	21.06	21.06
Resistance in adverse conditions												
7	Calm-water resistance	(kN)	$R_{cw}$	153.08	153.08	153.08	153.08	153.08	153.08	153.08	153.08	153.08
8	Aerodynamic resistance	(kN)	$R_{air}$	587.20	587.20	587.20	587.20	587.20	587.20	587.20	587.20	587.20
9	Added resistance in long-crested irregular waves	(kN)	$R_{aw}$	494.92	568.38	676.46	835.11	1062.70	1222.56	1299.33	1322.51	1296.01
Calculation of required brake power and torque in adverse conditions												
10	Required propeller thrust	(kN)	$T$	1446.37	1532.39	1658.94	1844.71	2111.22	2298.40	2388.29	2415.44	2384.42
11	Load factor		$K_T/J^2$	7.813	8.278	8.962	9.965	11.405	12.416	12.901	13.048	12.881
12	Advanced coefficient		$J$	0.194	0.189	0.183	0.174	0.164	0.158	0.155	0.154	0.155
13	Propeller revolution	(rpm)	$N$	39.08	40.11	41.57	43.62	46.39	48.23	49.09	49.34	49.05
14	Torque coefficient		$K_Q$	0.0343	0.0345	0.0346	0.0349	0.0351	0.0353	0.0353	0.0354	0.0353
15	Required brake power	(kW)	$P_{B,req}$	7056	7656	8566	9959	12068	13624	14392	14627	14359
16	Required torque	(kN*m)	$Q_{req}$	1724.16	1822.84	1967.82	2180.28	2484.37	2697.56	2799.84	2830.71	2795.43
Load diagram corresponding to propeller revolution												
17	Brake power on load diagram	(kW)	$P_{B,LD}$	11942	12256	12702	13328	14174	14737	14999	15077	14988
18	Torque on load diagram (Maximum torque)	(kN*m)	$Q_{max}$	2917.84	2917.84	2917.84	2917.84	2917.84	2917.84	2917.84	2917.84	2917.84
Judgement												
19	Judgement		$P_{B,req} \leq P_{B,LD}$	OK	OK	OK	OK	OK	OK	OK	OK	OK
20			$P_{B,req} / P_{B,LD}$	59.1%	62.5%	67.4%	74.7%	85.1%	92.5%	96.0%	97.0%	95.8%

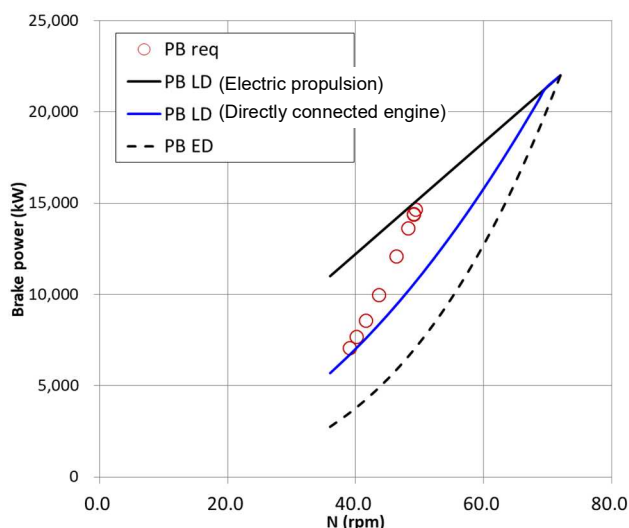

Figure Appendix 3.4-4: Load Diagram and Results of the Assessment of Minimum Propulsion Power

### C. General arrangement and bird's eye view

The general arrangement of the bulk carrier is shown in Figure Appendix 3.4-5, and a bird's eye view is shown in Figure Appendix 3.4-6. The general arrangement of the container ship is shown in Figure Appendix 3.4-7, and the bird's eye view is shown in Figure Appendix 3.4-8.

Figure Appendix 3.4-5(To be developed): General Arrangement of the Bulk Carrier (Supper-efficient LNG-fueled Ship)



Figure Appendix 3.4-6: Bird's Eye View of the bulk carrier (Supper-efficient LNG-fueled Ship)

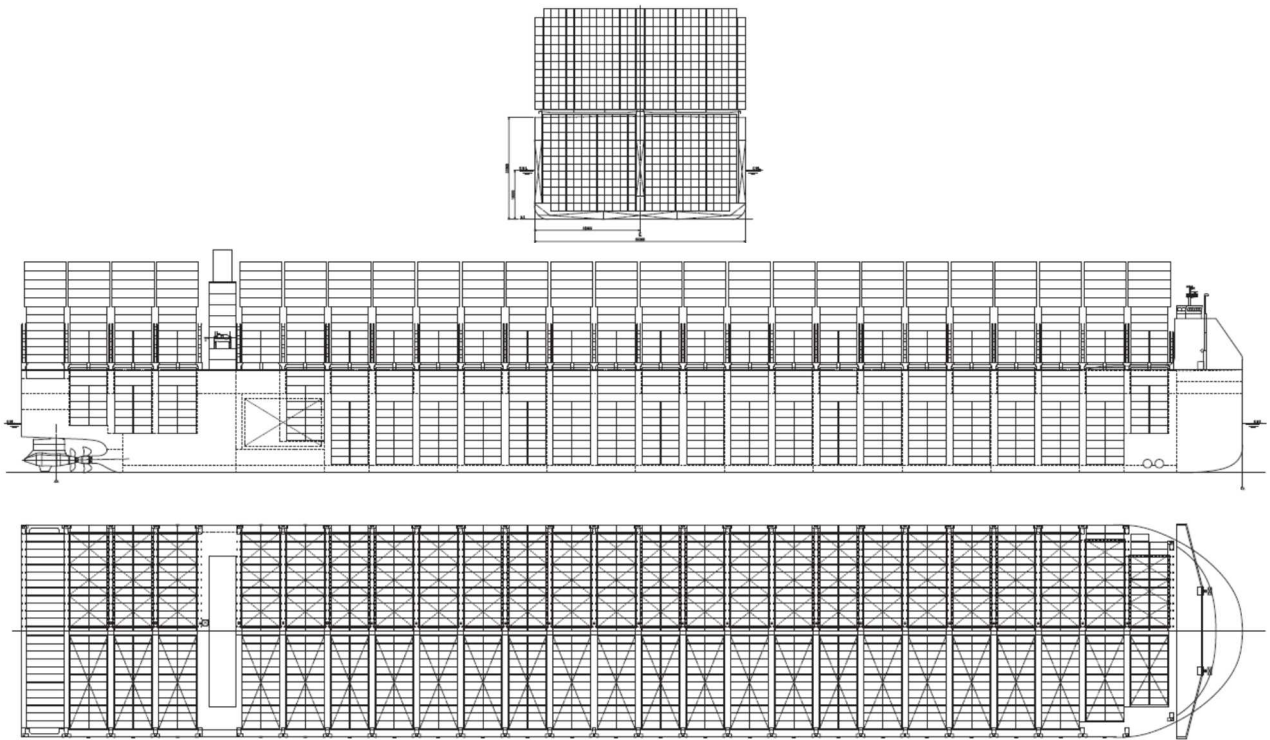

Figure Appendix 3.4-7: General Arrangement of the container ship (Supper-efficient LNG-fueled Ship)



Figure Appendix 3.4-8: Bird's Eye View of the Container Ship (Supper-efficient LNG-fueled Ship)



### **(3) Technological Issues to be Addressed for Practical Use of Supper-efficient LNG-fueled Ship**

These concept designs were developed based on available technologies whose introduction would be possible at present. Accordingly, the technological issues to be addressed to put them into practical use are not so significant. On the other hand, as described in Chapter 5, environmental arrangements, including reviews of the related IMO regulations and guidelines will be necessary for the actual introduction of the concept ships.

## Appendix 4. Life cycle accounting of GHG emissions

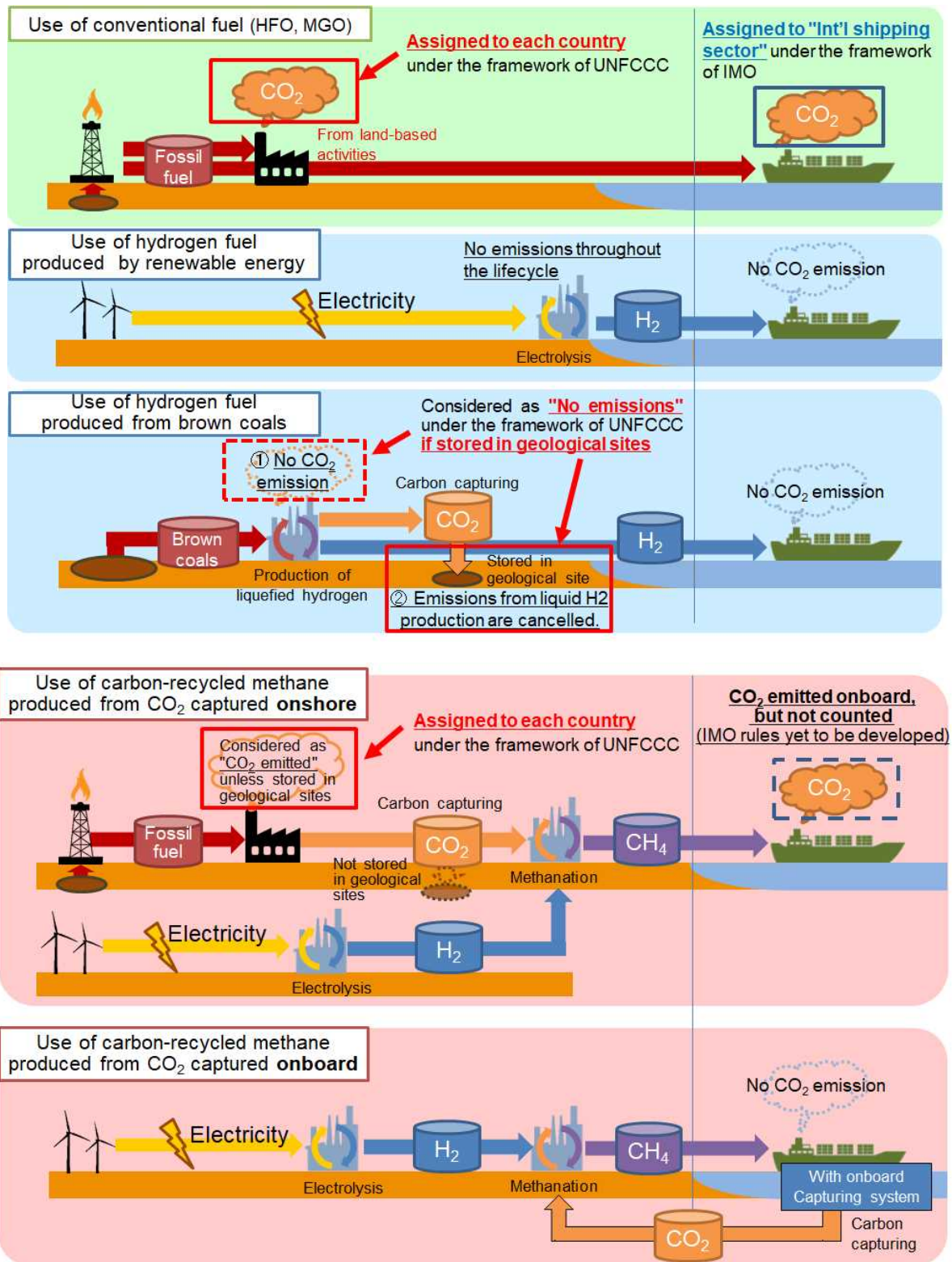

\* This appendix was made interpreting the 2006 IPCC Guidelines (including the 2019 Refinement) for this project. Use of these Guidelines is required in the calculation of a national greenhouse gas inventory under a decision (Decision 18/CMA.1) made at the 2018 Conference of the Parties serving as the meeting of the Parties to the Paris Agreement. How to account GHG emissions from international shipping using carbon-recycled fuels, etc. presented in these

appendices does not guarantee any conclusions to be made by the IMO in the future.